

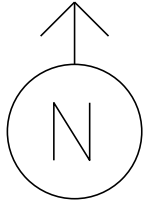







MS # 210

US 5 NORTH



-  CONTROL BOX
-  LOOP DETECTION
-  PULL BOX
-  LUMINAIRE
-  STANCHION
-  = 

VT 131 WEST

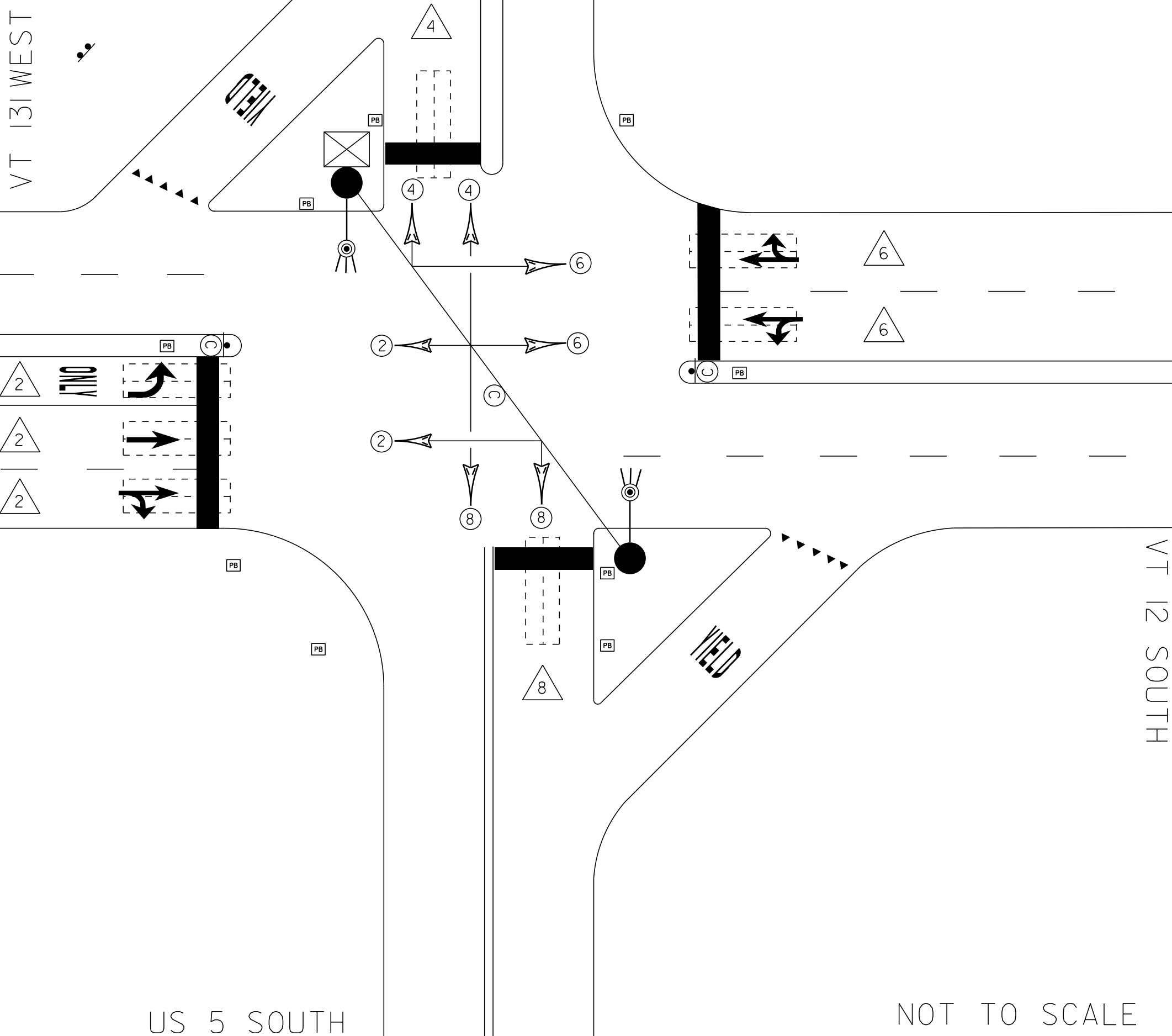

US 5 SOUTH

NOT TO SCALE

VT 12 SOUTH

MS # 210

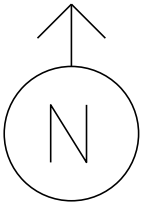

US 5 NORTH

VT 131 WEST

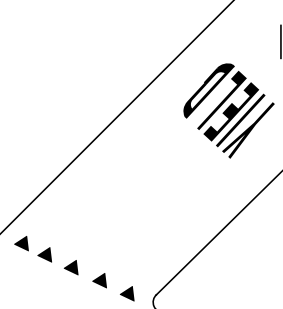

14'

14'



STOP BAR 20'

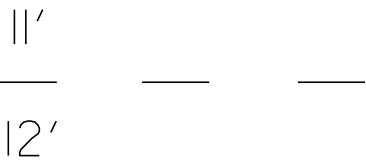

STOP BAR 32'

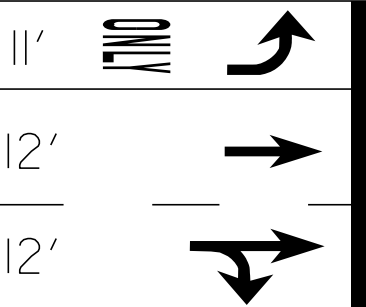
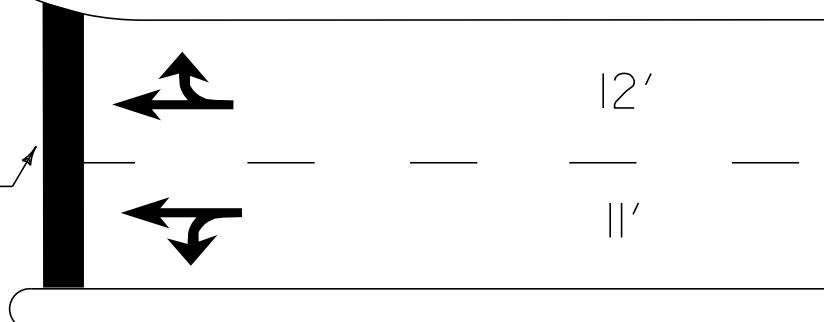

STOP BAR 35'

STOP BAR 15'



13'

15'

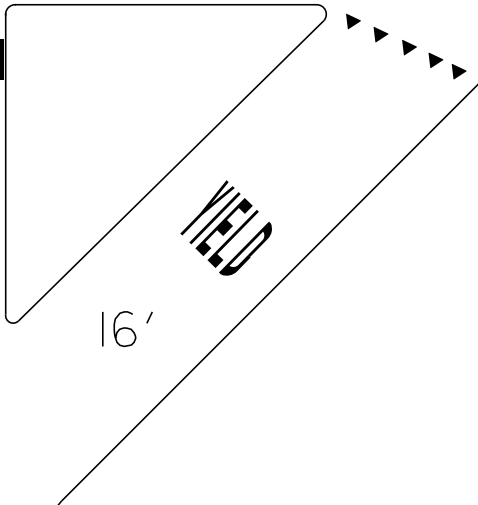

16'

VT 12 SOUTH

US 5 SOUTH

NOT TO SCALE

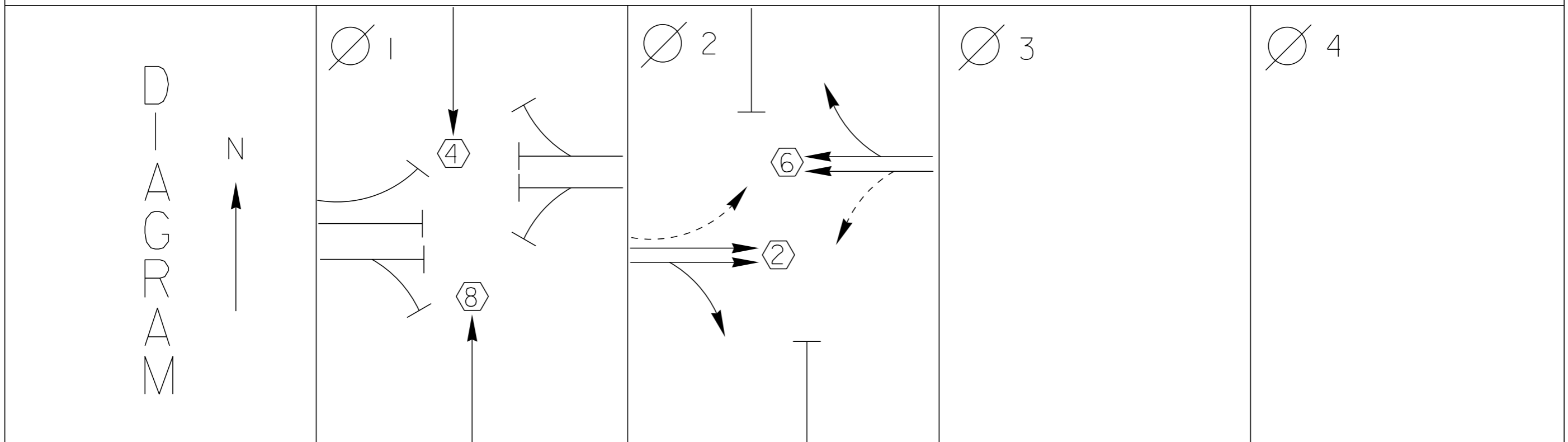

TIMING	G = Y =	G = Y =	G = Y =	G = Y =
--------	------------	------------	------------	------------

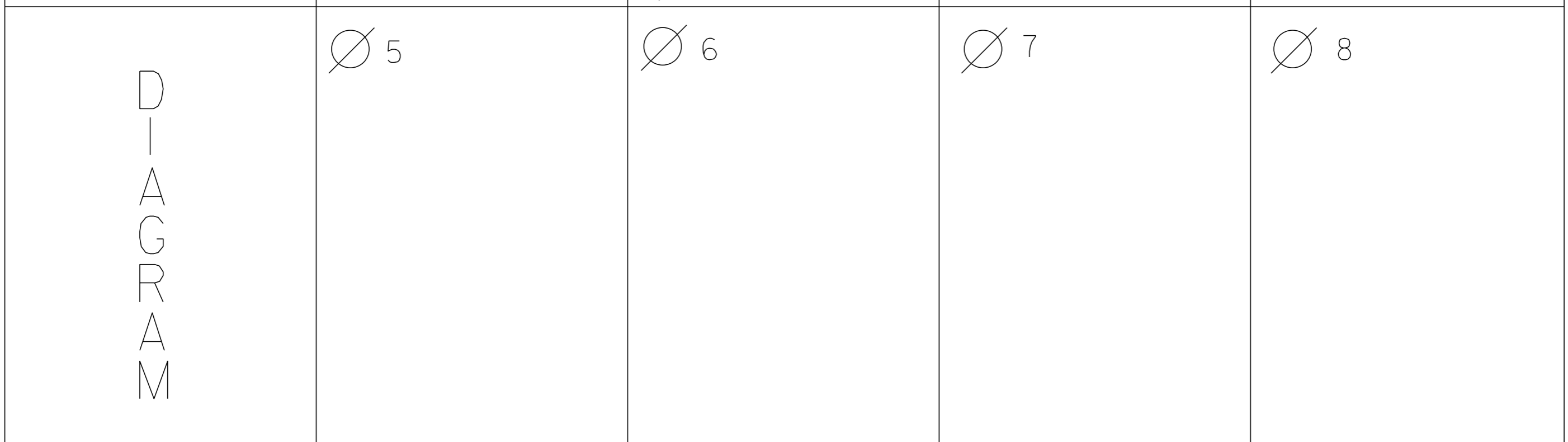

TIMING	G = Y =	G = Y =	G = Y =	G = Y =
--------	------------	------------	------------	------------

 PROTECTED TURNS	 PERMITTED TURNS PEDESTRIAN	CYCLE LENGTH, C= _____ S
---	---	--------------------------



END THE FED
ARREST THE BANKSTERS
UNOWARS.COM

PROPERTY OF:
VT. AGENCY OF TRANS.
MAINTENANCE DIV.
IN EMERGENCY CALL
DIST. TRANS. OFFICE
NIGHTS & WEEKENDS

PROPERTY OF:
VT. AGENCY OF TRANS.
MAINTENANCE DIV.

IN EMERGENCY CALL:
DIST. TRANS. OFFICE

854-6011

NIGHTS & WEEKENDS: 870-2112



WARNING

DO NOT OPERATE
CABINET WITHOUT
CONFLICT MONITOR UNIT

DANGER

115 VOLTS A.C.



ECONOLITE

RING STATUS: 8 INTERVAL TIMING | PHASE STATUS: 1 2 3 4 5 6 7 8 | COORD STATUS: FREE

4 NSPC 18 UEN | 10:40:11

8 NSPC 18 FPC |

16 NSPC 18 FPC |

F1 MAIN MENU | F2 SUB-MENU | F3 PAGE UP | F4 PAGE DOWN | F5 DISPLAY ADJUST | F6 STATUS DISPLAY

VISION NO/OFF | 1 2 3 | 4 5 6 | 7 8 9 | 0 CLEAR

PEC CALL | SPEC FUNC |

ASC 200

28 VDC 3 AMP SLO-BLO | 115 VAC 5 AMP BLOWER

A B C D

TELETERMINAL | TELEMETRY

RESET AFTER MODIFYING SWITCHES

FAULT | MONITOR FAIL | RESET | POWER | MODE | INC. PREV. FAIL

MIN. FLASH | DUAL SEL. | OPTIONS |

8421AB | ABCDEF | CY ENABLE | J | L | CM LOG DISABLE | W/O LATCH | WALK DISABLE

1 2 3 4 5 6 | 7 8 9 10 11 12

SSM 1 2 3 4 5 6 | SSM 7 8 9 10 11 12

ENABLE | ENABLE

1 AMP

ECONOLITE
CONTROL PRODUCTS, INC.
AMERICA 1978

CONFL. MONITOR



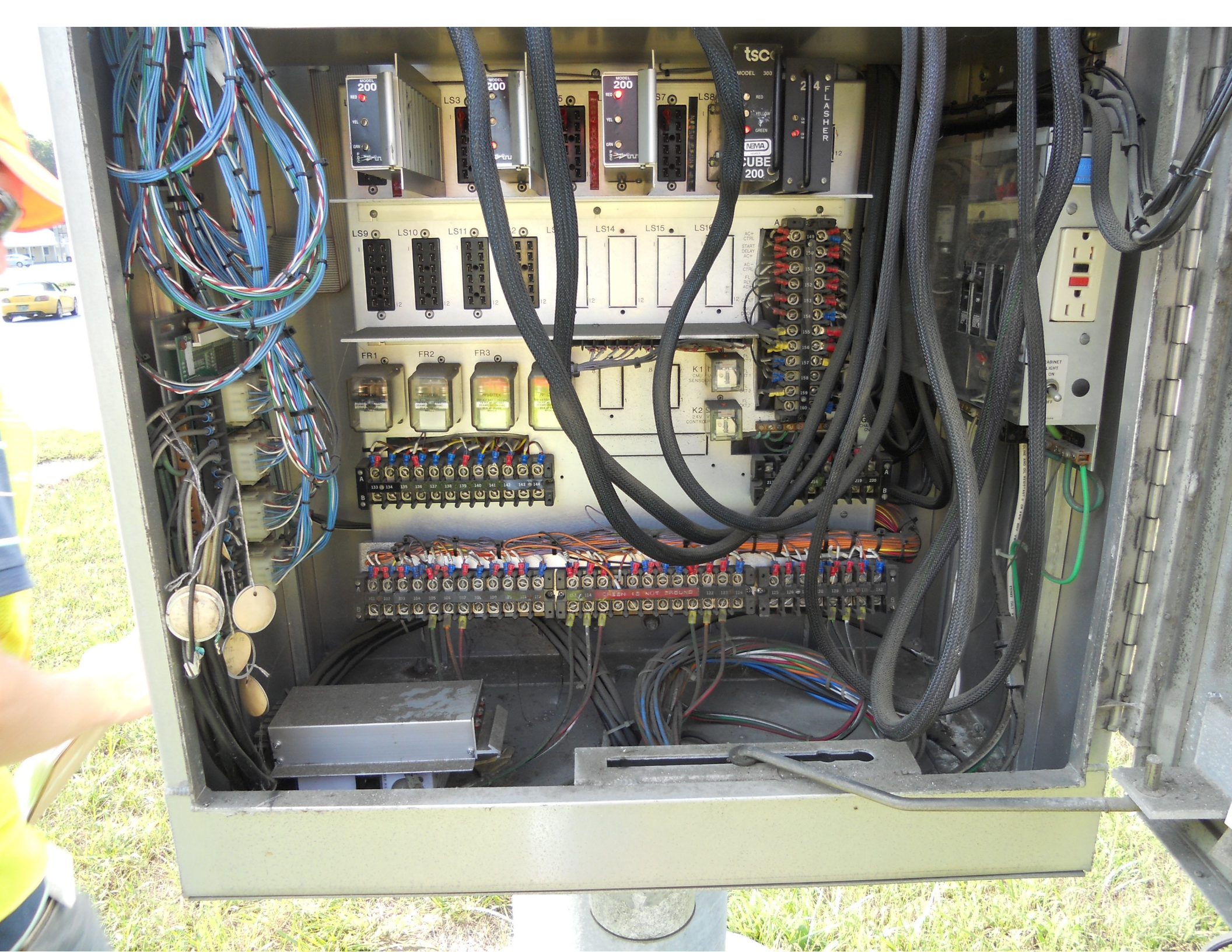

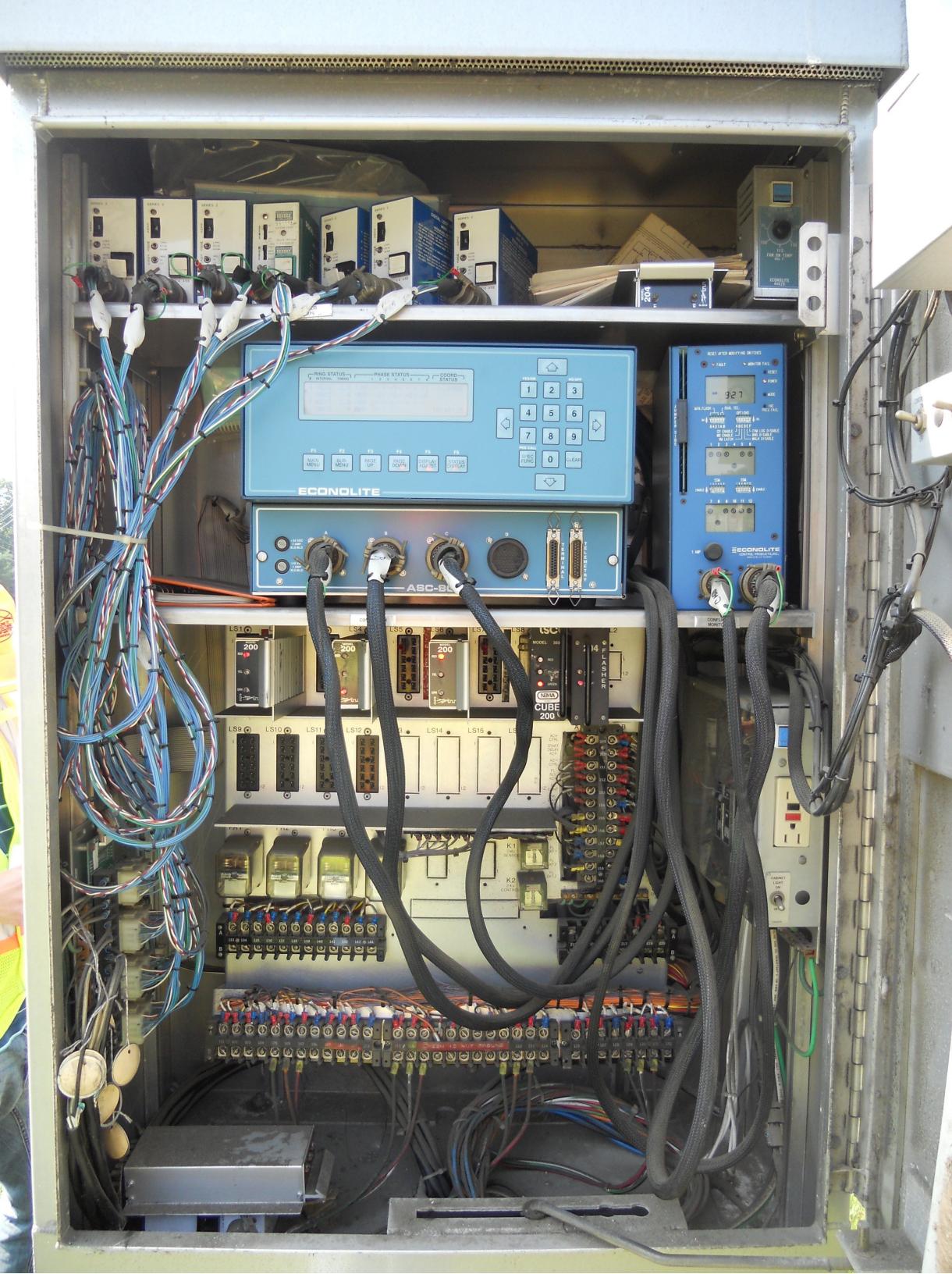



NORTH	SOUTH	SOUTH
5	VERMONT 12	5
←	↑	→
NORTH	VERMONT 12	
←		

DJ SERVICES
388-074-7878



LEFT
TURN
ONLY





LEFT TURN
YIELD
ON GREEN





LEFT TURN
YIELD
ON GREEN





WEST VERMONT 131 ←
NORTH VERMONT 5 ↑
SOUTH VERMONT 12 →
TO INTERSTATE 91 ←
NORTH VERMONT 12 ↑

WALSH'S
REAL ESTATE

Shell

WALSH'S
REAL ESTATE

WALSH'S
REAL ESTATE



	CASH	CREDIT
REGULAR UNLEADED	342	342
PLUS UNLEADED	352	352
PREMIUM UNLEADED	362	362

DIESELECT PREMIUM DIESEL	389	389
--------------------------	-----	-----





356
409
FULL SERVE

ITCHES

356
409

356
409





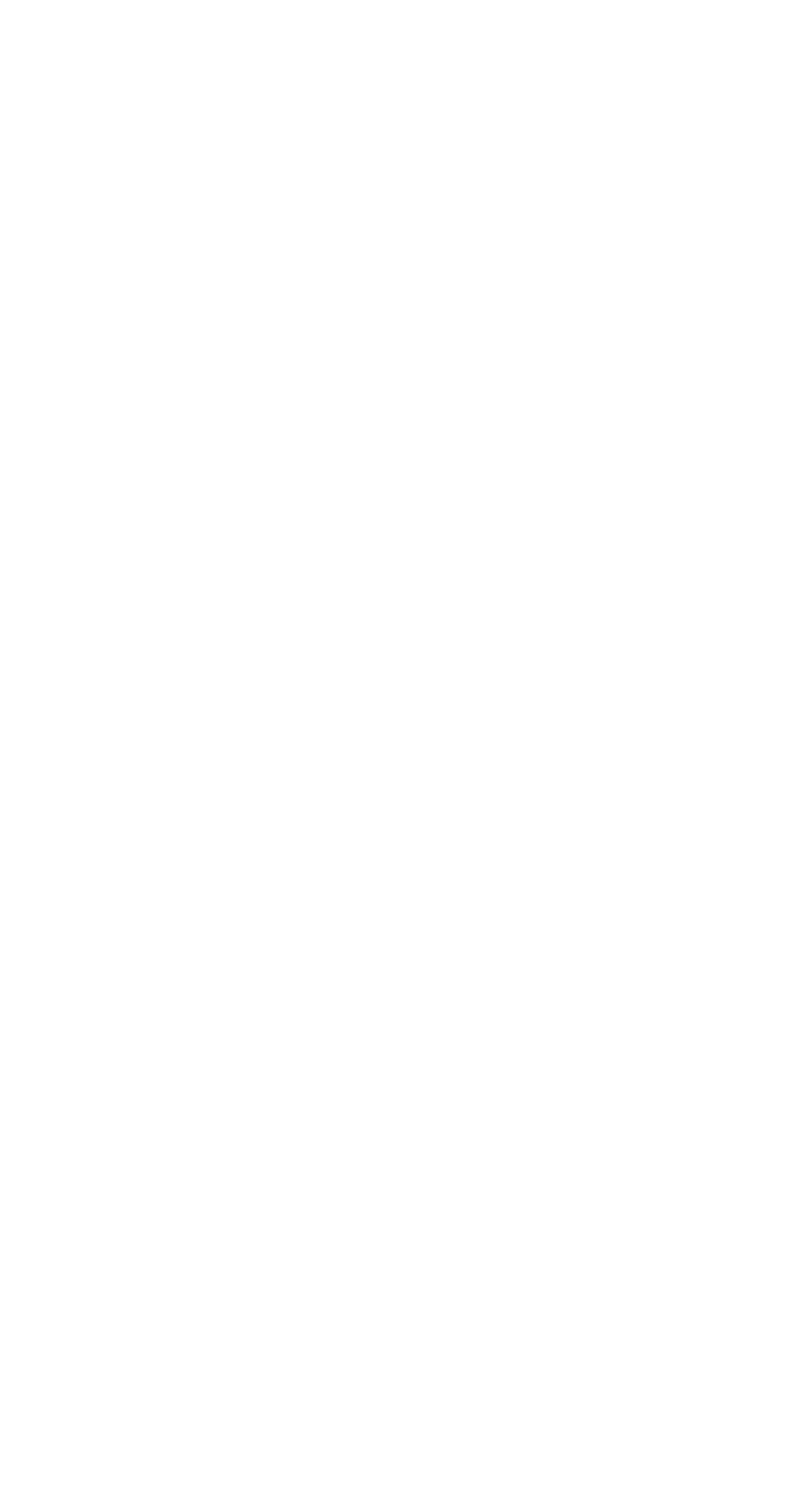



1411N33
48KS13GA



356
409
FULL SERVE

7-11

7-11

7



LEFT TURN
YIELD
ON GREEN





VA 01
7-92
US 5



SOUTH VERMONT 12 ←

SOUTH 5 ↑

WEST VERMONT 131 ↗

TO INTERSTATE 91 ↗

ATCO STANBELLS

LEHAULU









LEFT TURN
YIELD
ON GREEN





1411/29
48K333GA

NIC Program Data

Step No.	Pgm	Time	Cycle	Offset	Split	Flash	Dim	Max2	Max3	Sp Functions			
										1	2	3	4
1	1	0600	1	0	1
2	1	1000	2	0	1	.	.	X
3	1	1400	3	0	1	.	.	.	X
4	1	2200	1	0	1	X
5	2	0500	1	0	1
6	2	0900	2	0	1	.	.	X
7	2	1300	3	0	1	.	.	.	X
8	2	2200	1	0	1	X
9	3	0700	1	0	1
10	3	1100	2	0	1	.	.	X
11	3	1500	3	0	1	.	.	.	X
12	3	2300	1	0	1	X