

Construction Notes

1. The Contractor will be responsible for all construction of water main, storm and sanitary sewer systems as shown on the plans. The Contractor will be responsible for all necessary adapters, fittings, etc. to make connections to the existing and proposed units. The Contractor shall be responsible for all work shown or implied on the plans and/or referenced in the specifications and permits. The Contractor shall submit, for approval by the Engineer, all types of materials and products used.

Water Main

- The pipe for water main shall be CL52 ductile iron. Ductile iron fittings shall conform to AWWA C110, 350 pounds working pressure. Valves shall be manufactured to meet all requirements of AWWA specification C509.
- The pipe for water service shall be copper type k. Copper tubing shall meet the requirements of Federal Specification WW-T 7996 and shall conform to ASTM specification B-75, B-88 and B-68 as they apply to type k copper tubing.
- All pipe shall be installed in accordance with AWWA C600. The pipe shall be kept free of foreign matter and debris during installation. When the process of pipe laying has stopped, any open ends of pipe shall be plugged. There shall be a minimum of 6'-0" (1.82 m) cover over all pipe and service lines. Any pipe deflection shall not exceed fifty (50%) percent of recommended manufacturer's maximum deflection. Backfill materials and procedures shall be as detailed on the drawings. The Contractor shall be responsible for any and all sheeting and/or shoring necessary to comply with OSHA - VOSHA regulations.
- The testing of the water main shall consist of the testing of all installed pipe, services and hydrants in accordance with AWWA C600 (except as noted). The testing shall consist of a pressure test and leakage test. All testing shall be done with potable water and in the presence of the Engineer. The pressure test consists of maintaining a minimum internal pipe pressure of 200 psi (140,620 kg/m²) for two (2) hours. If the pressure drops more than 5 psi (3515 kg/m²) in the first hour, this constitutes failure of the test for the particular section of pipe. Failure of any test section will necessitate repair and/or replacement of the failed section.
- Chlorination of the system shall be accomplished after the water main has been successfully pressure tested and thoroughly flushed. Disinfection shall be in accordance with AWWA C-651. The disinfection process shall be deemed acceptable only after two samples of water from the flushed disinfected main shows no evidence of bacteriological contamination. Use minimum 50 mg/l chlorine concentration for 24 hours. The concentration must remain above 25 mg/l. Tablet disinfection is not acceptable.

Testing and Notes

- In addition to the above requirements, all water lines and sewer lines and manholes shall be thoroughly tested by the Contractor in accordance with the Environmental Protection Rules 8/8/96, and A.O.T standards.
- No water main shall be closer than ten (10) feet to any sanitary sewer, storm sewer or sanitary manhole and five (5) feet to any catch basin. Provide minimum of 18" vertical separation between water main and storm/sanitary sewer.
- The Contractor shall keep a log book of at least three swing ties to service locations, and any water main fittings. Books shall be turned over to the State of Vermont upon acceptance of the work. Elevations to the top of services shall also be recorded.

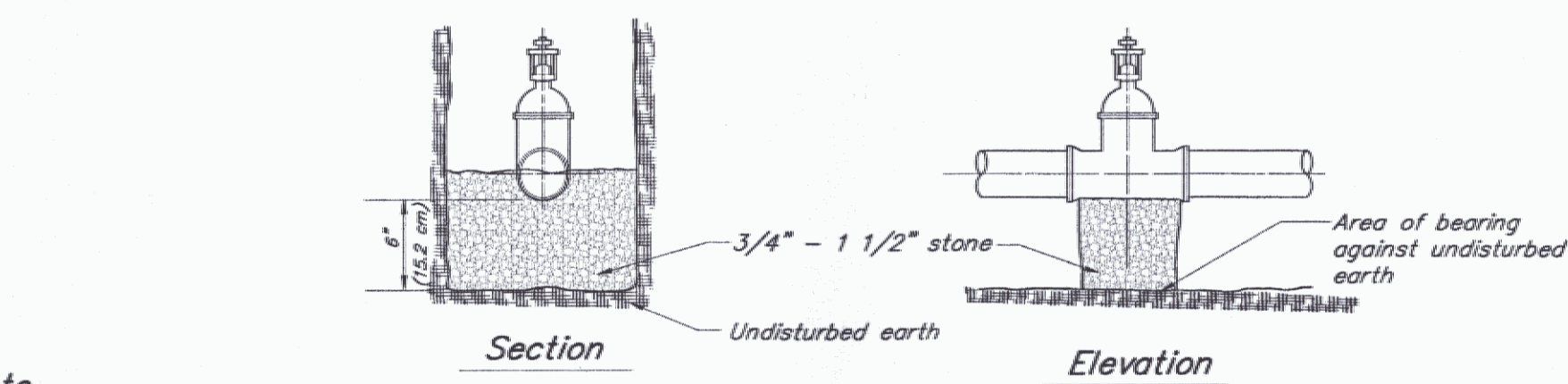
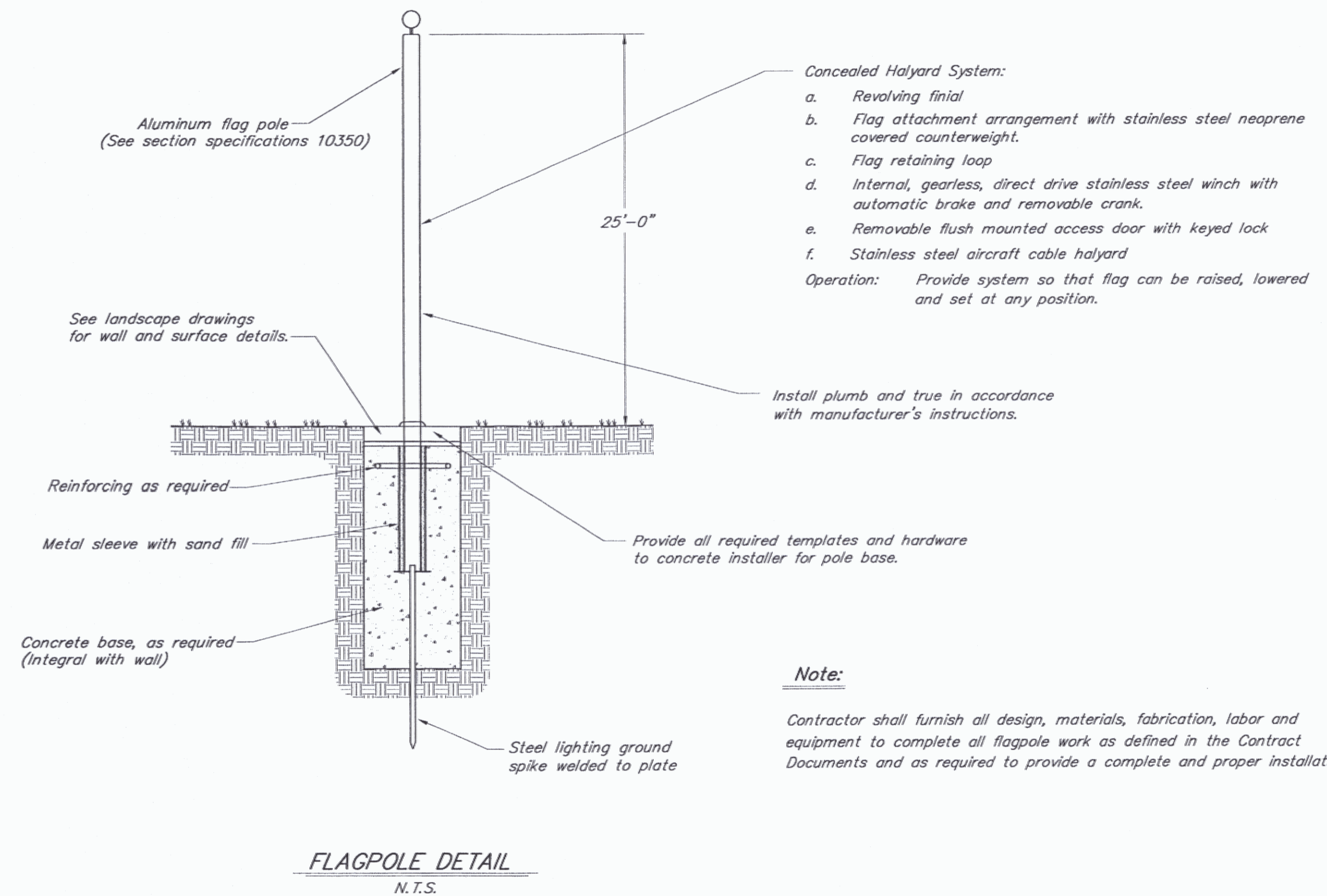

Note

- A thrust block shall be installed at all water main bends, end caps, and tees.
- Precast thrust blocks are not acceptable.
- "Sac-crete" may be used for thrust blocks only if mix is pre-tested by mutually accepted testing laboratory (paid for by the contractor) and if one cylinder is taken for each batch of "Sac-crete". (28 day strength = 3,500 PSI)
- Use mega-lug retainer glands at all fittings.

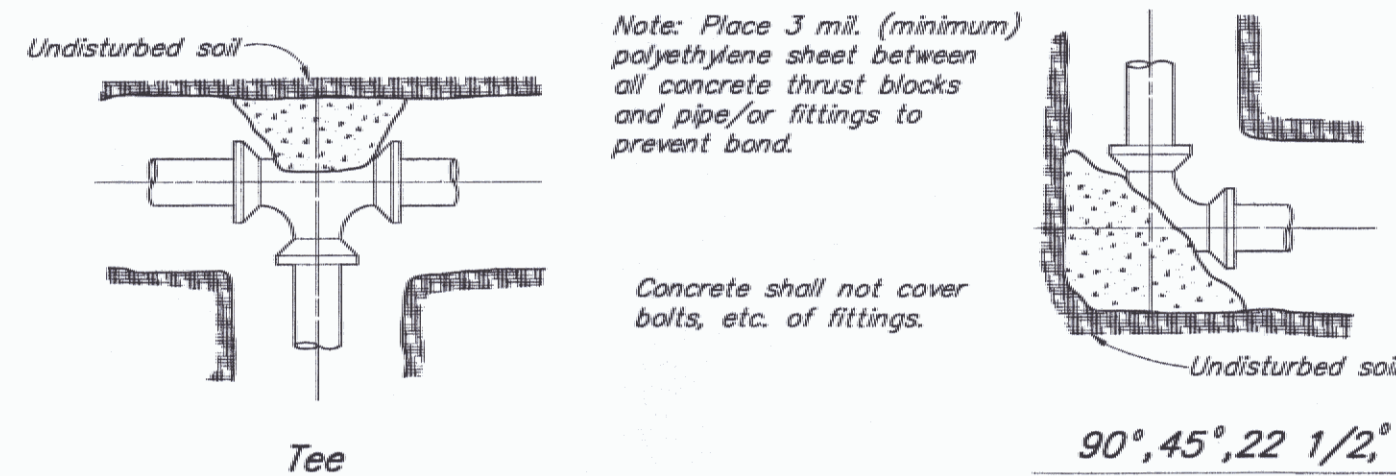
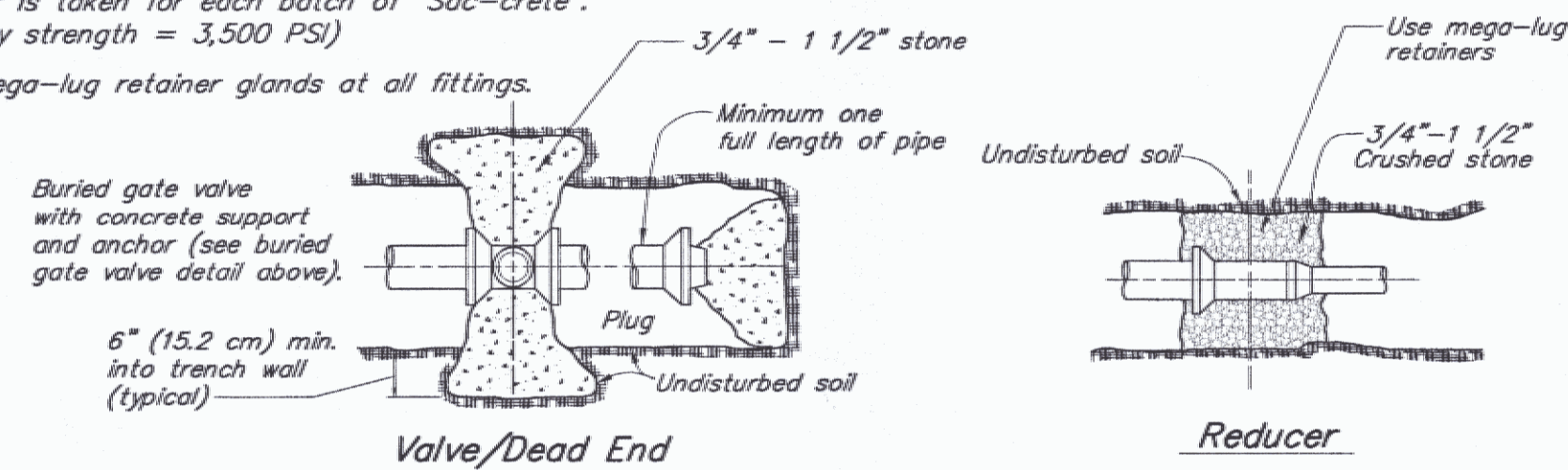

Minimum Area of Bearing Surface of Concrete Thrust Block (in square feet)

3"		4"		6"		8"		12"		SOIL CONDITION	SAFE BEARING LOAD(P/SF)						
ENDS & REES	VALVES & REDUC.	ENDS & REES	VALVES & REDUC.	ENDS & REES	VALVES & REDUC.	ENDS & REES	VALVES & REDUC.	ENDS & REES	VALVES & REDUC.								
0.5	0.5	0.5	0.5	1.0	1.5	1.0	0.5	2.0	2.5	1.5	1.0	4.0	5.5	3.0	1.5	Sound shale	10,000
1.0	1.0	1.0	0.5	1.5	2.0	1.0	0.5	3.0	4.0	2.0	1.0	4.5	6.5	3.5	2.0	Cemented gravel & sand	4,000
1.0	1.0	1.0	0.5	2.0	0.5	1.5	1.0	3.5	5.0	3.0	1.5	6.0	8.5	5.0	2.5	Coarse & fine compact sand	3,000
1.5	2.5	1.5	1.0	2.5	3.5	2.0	1.0	5.5	7.5	4.0	2.0	9.0	13.0	7.0	3.5	Medium clay (can be spaded)	2,000
3.0	4.5	2.5	1.5	5.0	7.0	4.0	2.0	10.5	15.0	8.0	4.0	18.0	25.0	14.0	7.0	Soft clay	1,000

Maximum water pressure = 200 PSI (140,620 kg/m²)

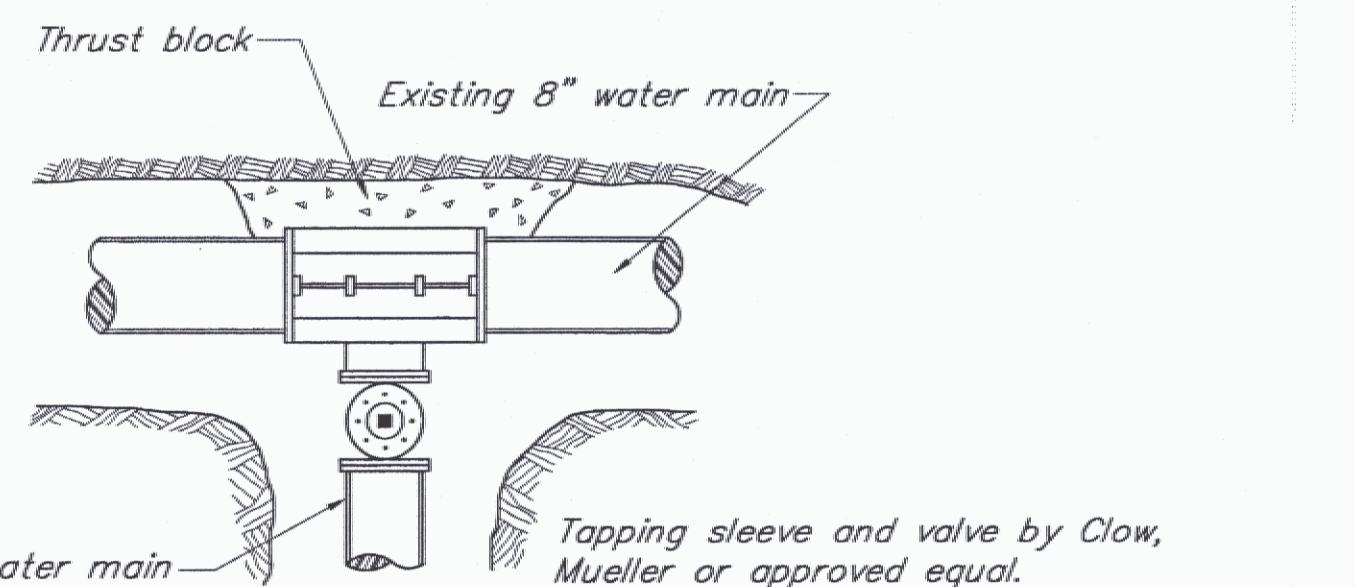

Contact the Engineer 48 hours prior to tap.

Wet tap shall be installed by persons approved by State of Vermont and Engineer.

Typical Water Trench Details

N.T.S.

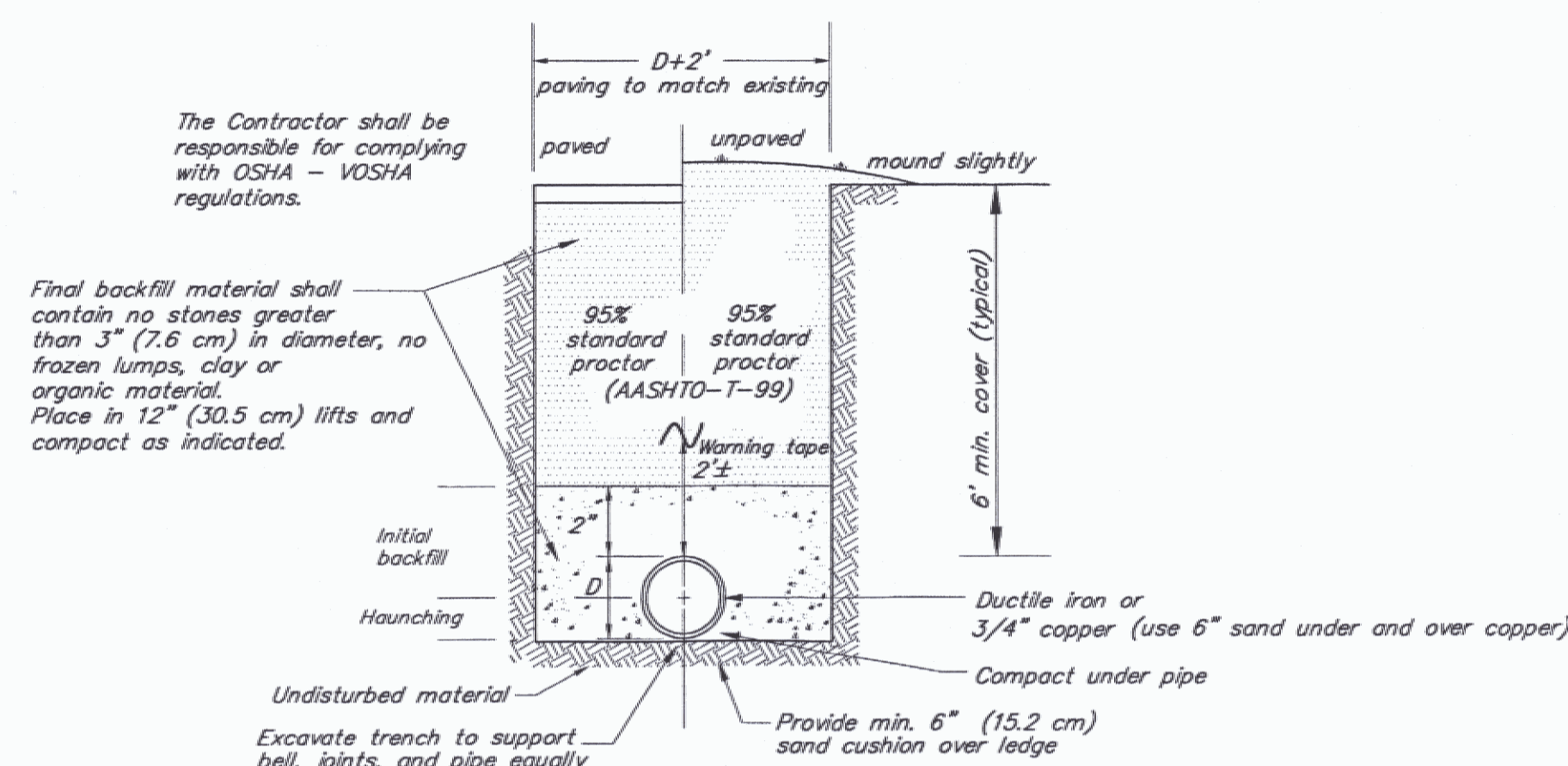

Stormwater System Maintenance Schedule

- The stormwater system is comprised of any portion of the site that directs or conveys water.
- All ditches and swales must be inspected regularly and repaired as required. Special attention must be given to winter time ice conditions.
- The detention basin must be inspected quarterly and after rainstorms of 1/2" or greater. Clean and/or repair as required.

* Contractor to provide gate valve wrench to Owner at substantial completion of the project.

- Gate valves shall be A.W.W.A. C 509 Standard Gate Valves with mechanical joints of sizes as required on the plans. All valves shall be of ductile iron.
- All valves shall be of cast or ductile iron body, parallel brass seats, non-rising stem, inside screw, double disk construction with "O" Ring Stem Seals.
- The gate valves shall open counterclockwise and be designed for a working pressure of 200 psi.
- All valves to be equipped with a valve box for a minimum of 6 feet (6') of cover material.

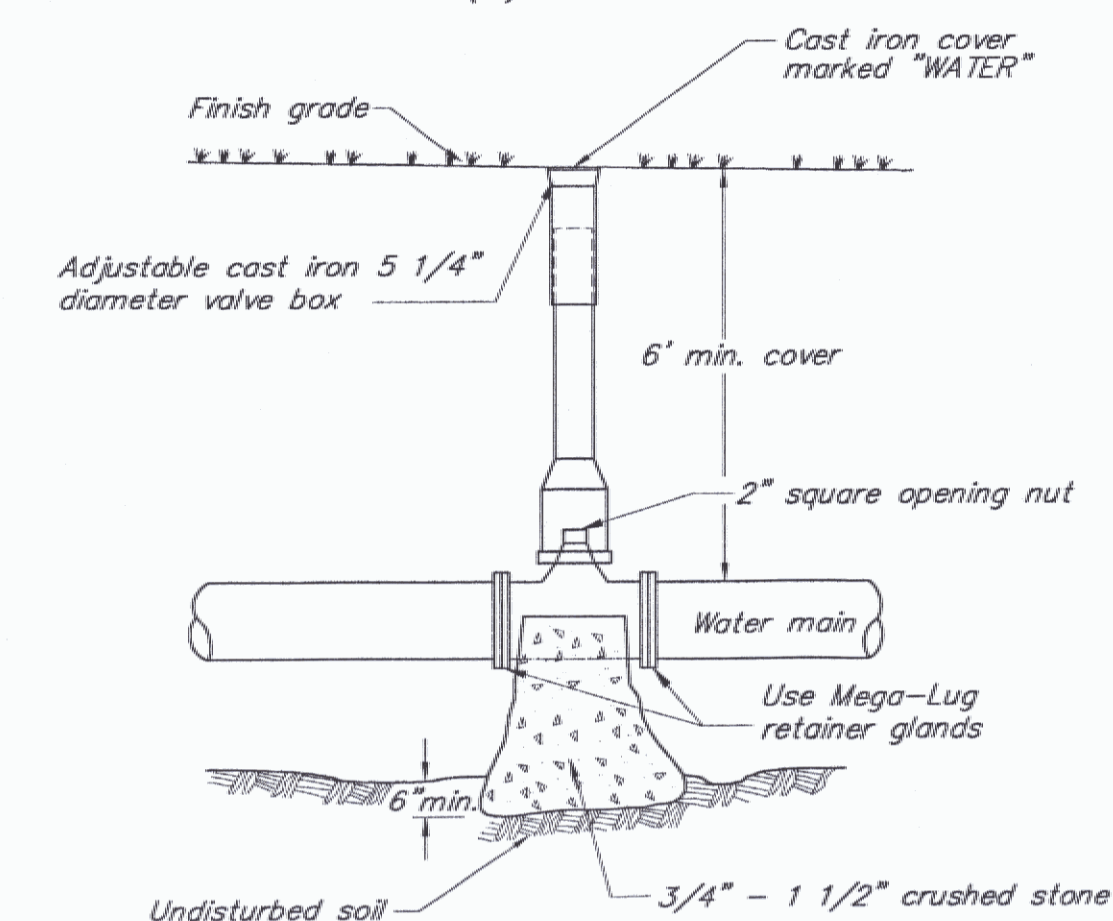

Typical Resilient Seat Gate Valve

N.T.S.

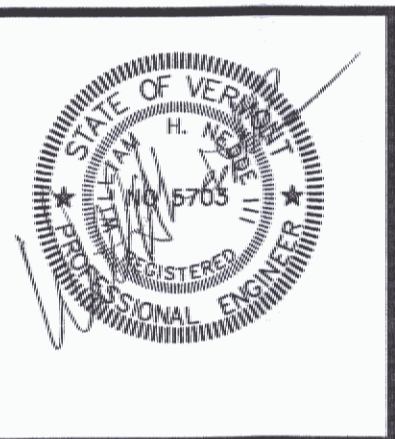

NORTHERN ARCHITECTS

207 KING STREET
SUITE 3
BURLINGTON, VERMONT
05401-4502

802-658-1953

CONSULTANTS

CIVIL
KEEPS ENGINEERING
164 Main Street, Suite 201,
Colchester, VT 05446
(802) 878-0575

LANDSCAPE ARCHITECT
OHKW
OFFICE OF PLANNING
7 Trade Avenue
Dundee, VT 05401
(802) 864-0010

STRUCTURAL
EDWARD H. DORRITY, P.E.
117 SAINT PAUL STREET
BURLINGTON, VT 05401
802-660-9912

MECHANICAL/ELECTRICAL
DUFFRENE-RENNY, INC.
24 ROUTE 104, FERRISBURGH PARK
NORTH SPRINGFIELD, VT 05450
802-886-2261

REVISIONS

PROJECT

DERBY WELCOME CENTER
PROJECT #101-3181

NEW FACILITY

DERBY VERMONT

DATE: 01/07/02

SCALE: AS NOTED

CHECKED:

PROJECT NO: 00137

DETAILS

SC-26

00137 - SC-26.dwg