

POST SIZE (LB/FT.)	DIMENSIONS			SECTION MODULUS, X-X
	A	B	C	
2	1 1/2"	1 3/4"	3 1/8"	0.225 IN. <sup>3</sup>
2 1/2	1 3/2"	1 3/4"	3 1/8"	0.289 IN. <sup>3</sup>
3	1 3/4"	1 7/8"	3 1/2"	0.403 IN. <sup>3</sup>

SIMILAR DIMENSIONS ARE ACCEPTABLE, HOWEVER SECTION MODULUS VALUES SHALL NOT BE EXCEEDED.

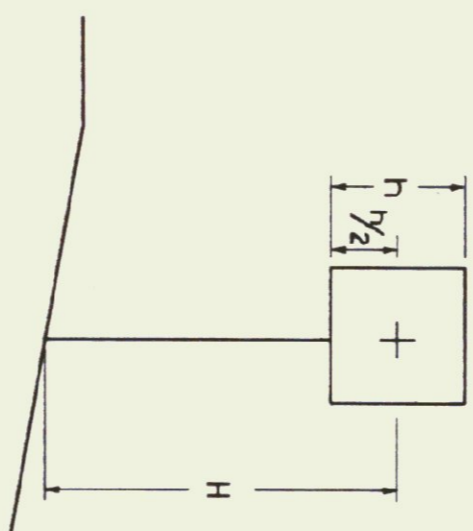

**POST SELECTION CHART**

POST SIZE	SV	DESIGN CRITERIA
2 LB./FT. (ONE POST INSTALLATION)	32	WIND SPEED = 60 MPH (10-YEAR MEAN RECURRENCE INTERVAL)
2 LB./FT. (TWO POST INSTALLATION)	62	WIND PRESSURE = 15 PSF
2.5 LB./FT. *	77	STEEL MIN. YIELD F <sub>y</sub> = 50,000 PSI
3 LB./FT.	107	ALLOWABLE STRESS = (1.4) 0.60 F <sub>y</sub>

SINGULAR 2 LB./FT. POSTS SHALL ONLY TO BE USED IN URBAN AREAS. 2.5 LB./FT. POSTS SHALL NOT BE USED FOR NEW INSTALLATIONS. INFORMATION IS PROVIDED ONLY FOR CHECKING RETAINED POSTS.

REVISIONS AND CORRECTIONS  
 MARCH 1, 1988 - FHWA REVIEW COMMENTS  
 OCT 21, 1992 - ADDED DETAILS, REVISED NOTES  
 & REVISED TITLE BLOCK

APPROVED \_\_\_\_\_ DATE SEPT. 10, 1987

*Stephen D. Theobald*  
 DIRECTOR OF ENGINEERING  
*David A. Remy*  
 TRAFFIC AND SAFETY ENGINEER

\* - THE DIMENSION 2L/6 MUST EXCEED 3' - 9" OR A THREE POST ASSEMBLY SHALL ONLY BE USED BEHIND GUARDRAIL AT A DISTANCE 2 DEFLECTION DISTANCE. (SEE CHART)

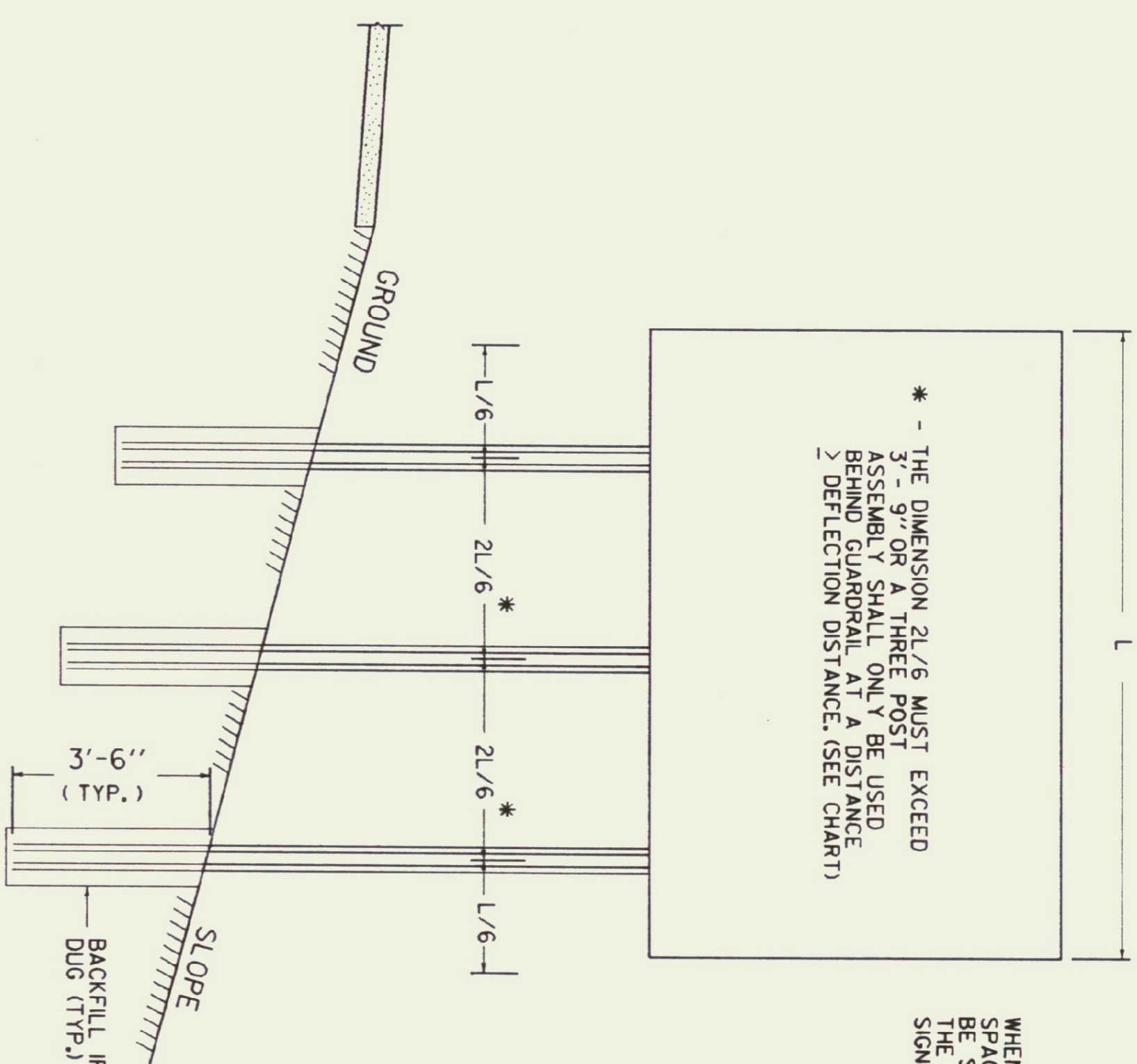

**MULTI-POST INSTALLATIONS**

WHEN SIGN POSTS ARE INSTALLED WITH A POST SPACING OF LESS THAN 8 FEET, POST SIZES MUST BE SELECTED TO INSURE THAT WHEN ACTING TOGETHER THE POSTS DO NOT CREATE A HAZARD. REFER TO V.A.O.T. SIGN POST DESIGN GUIDELINE FOR ADDITIONAL DETAILS.

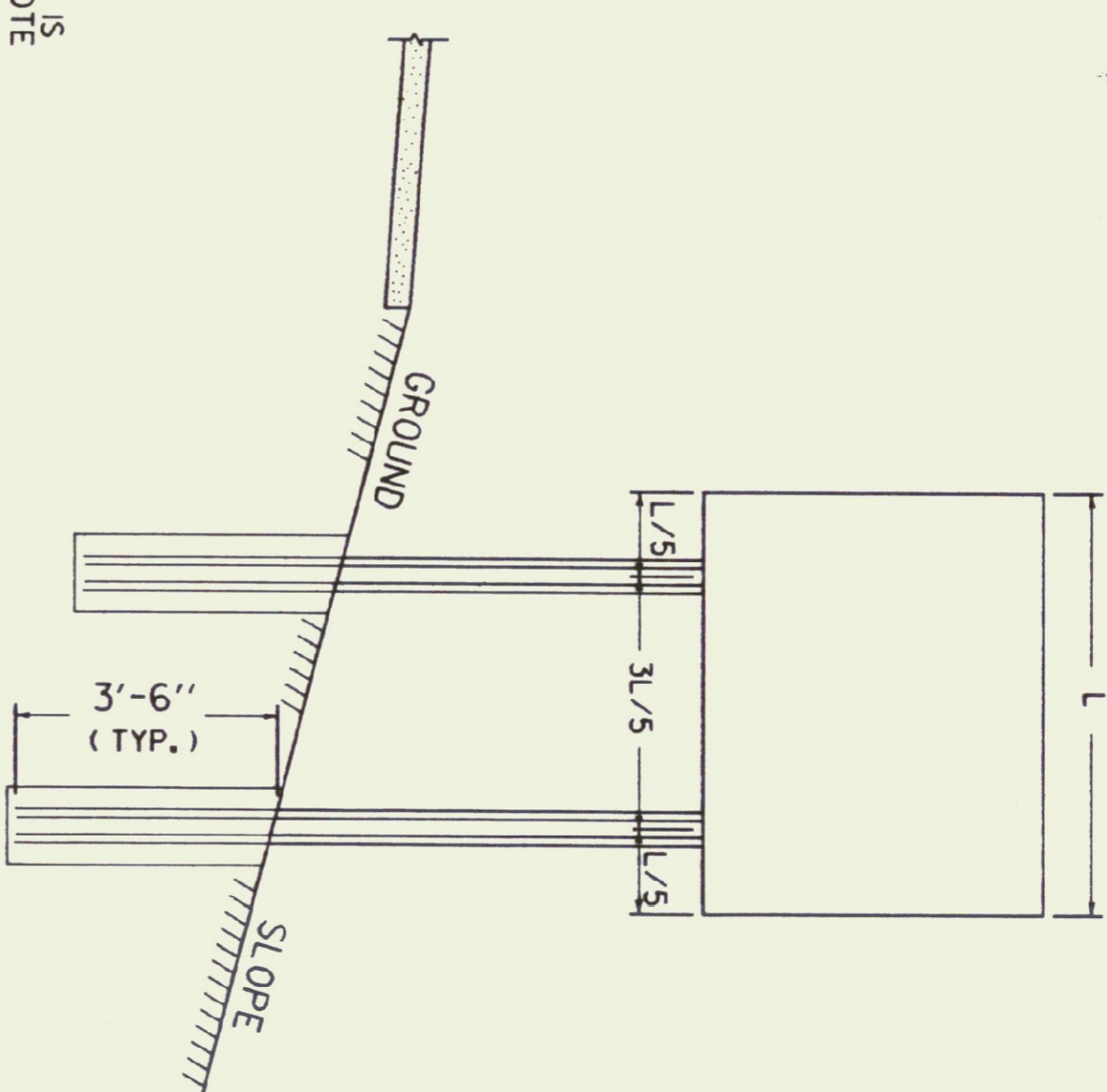

**POST SPACING DETAILS**

**GUARDRAIL DEFLECTION CHART**  
 (PER AASHTO - ROADSIDE DESIGN GUIDE - 1988)

TYPE	GR POST SPACING	DEFLECTION
THREE CABLE W/STEEL POSTS	16' - 0"	12'
W/WOODEN POSTS	12' - 6"	12'
W-BEAM W/WEAK POST	12' - 6"	7'
W/STRONG POST	6' - 3"	3'
BOX BEAM	6' - 0"	5'
THREE BEAM W/WEAK POST	12' - 6"	4'
W/STRONG POST	6' - 3"	2'
TWO-RAIL ELLIPTICAL ALUMINUM		2'

THIS CHART LISTS THE THEORETICAL DEFLECTION DISTANCE UPON IMPACT OF VARIOUS GUARDRAIL WITH DIFFERENT TYPES AND SPACING OF POSTS.

**GENERAL NOTES**  
 CONSTRUCTION METHODS - POSTS MAY BE DRIVEN OR SET IN A DUG HOLE AND BACKFILLED. IF DRIVEN, A DRIVING CAP SHALL BE USED. THE DUG HOLE INSTALLATION SHALL BE USED IN AREAS OF POOR SOIL CONDITIONS OR AS DIRECTED BY THE RESIDENT ENGINEER. BACKFILL SHALL BE COMPACTED AS DIRECTED BY THE RESIDENT ENGINEER.  
 SIGN CLEARANCES - HORIZONTAL AND VERTICAL SIGN CLEARANCES SHALL BE SHOWN ON THE PLANS OR THE APPROPRIATE STD. SHEETS. SINGLE POST INSTALLATIONS SHALL BE LIMITED TO A SIGN AREA OF 1/2 SQ. FT. OR LESS

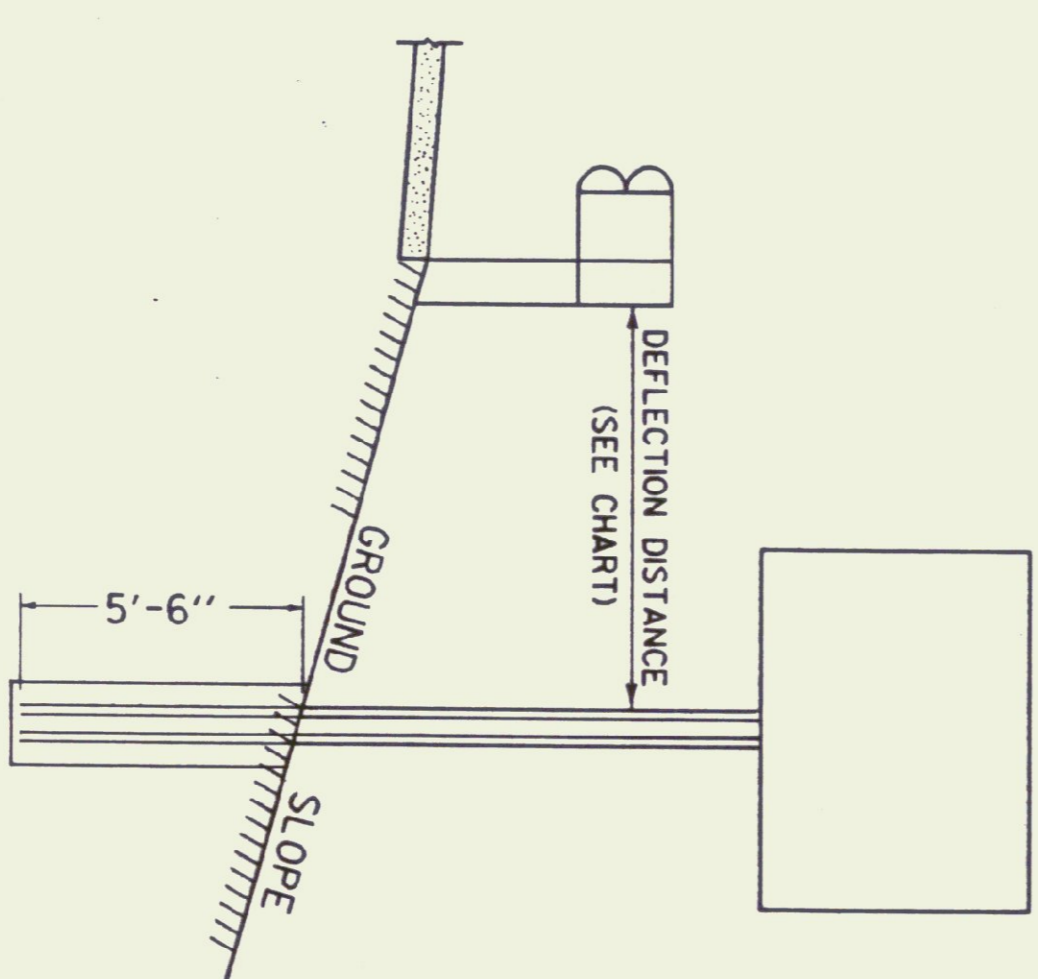
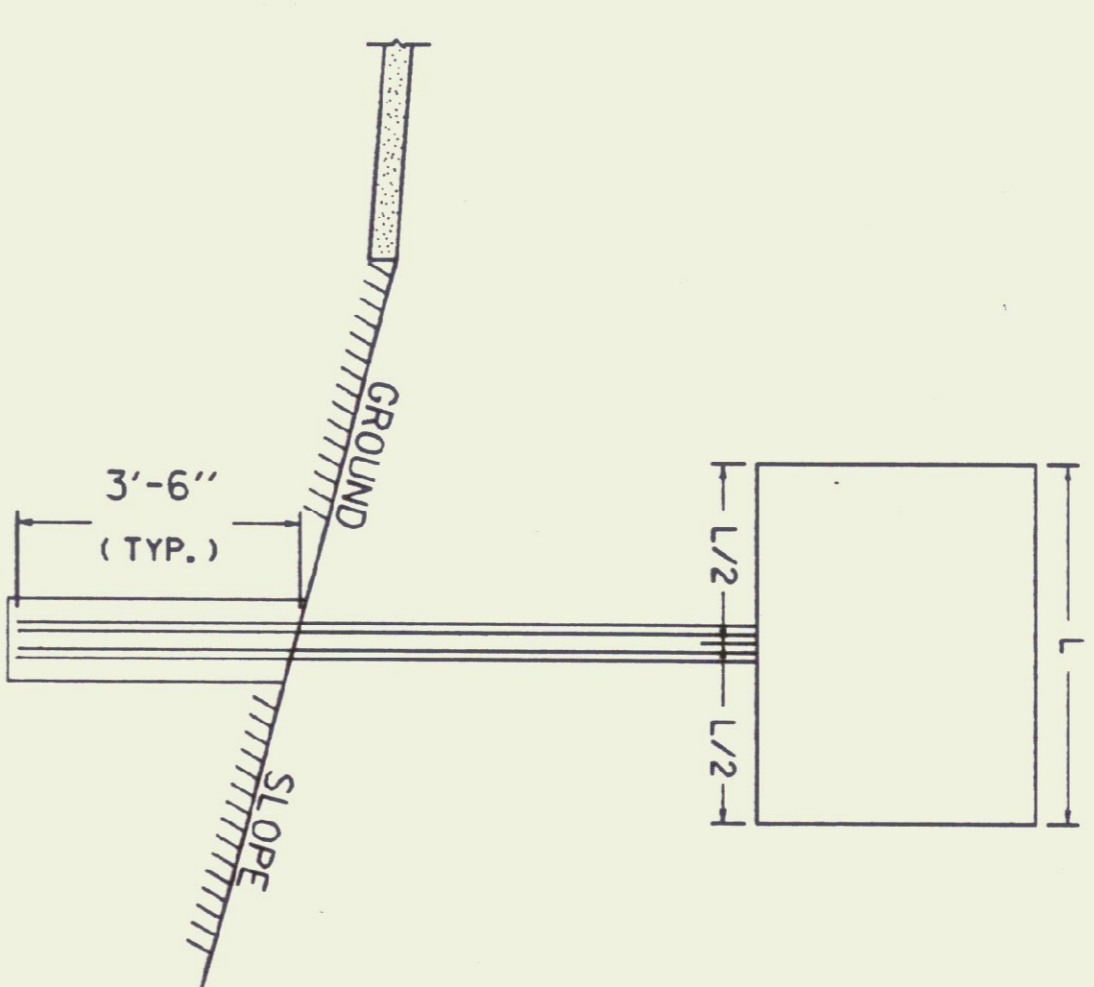

WHEN USING FLANGED CHANNEL POSTS ON STEEP SLOPES (ION 2 OR STEEPER FILL SLOPES BEHIND GUARDRAIL, ADD 2' EMBEDMENT TO THE POST LENGTH. HOWEVER, THE ASSEMBLY MORE STABILITY. HOWEVER, SIGN POSTS LOCATED INSIDE THE DEFLECTION DISTANCE, THE SIGN POST SHALL BE SET AT A DEPTH OF 3' - 6'.

**FLANGED CHANNEL STEEL SIGN POST**

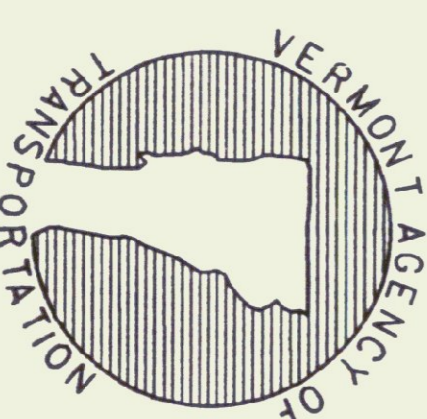

**STANDARD E-160**