

1 TYPICAL PAVEMENT SECTION  
N.T.S.

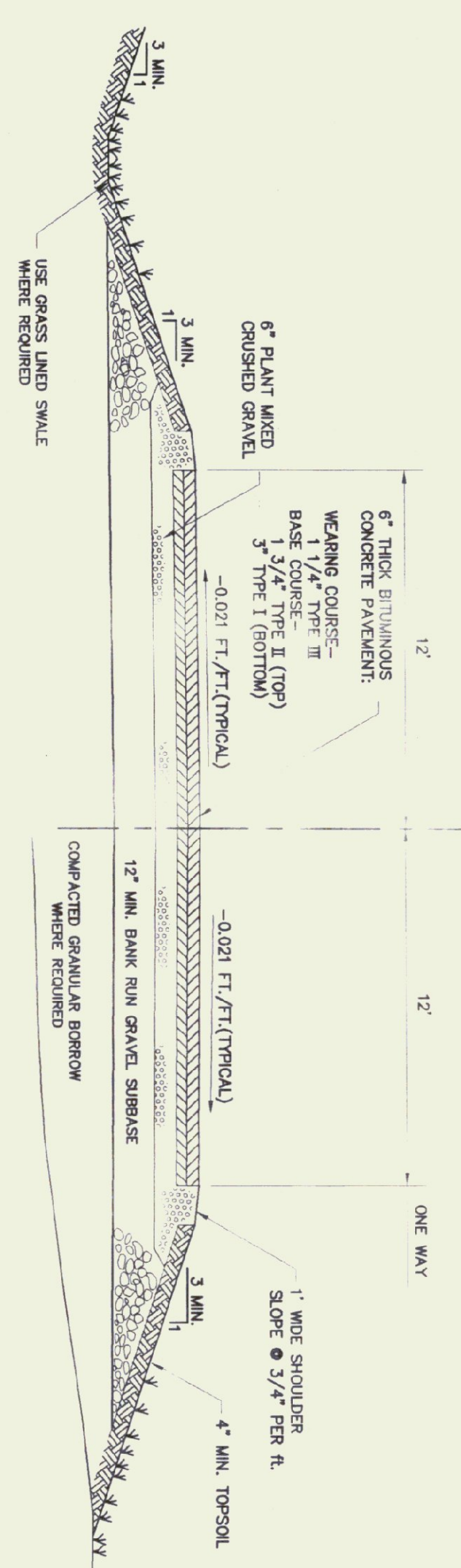

2 TYPICAL COMMERCIAL ENTRANCE CROSS-SECTION  
N.T.S.

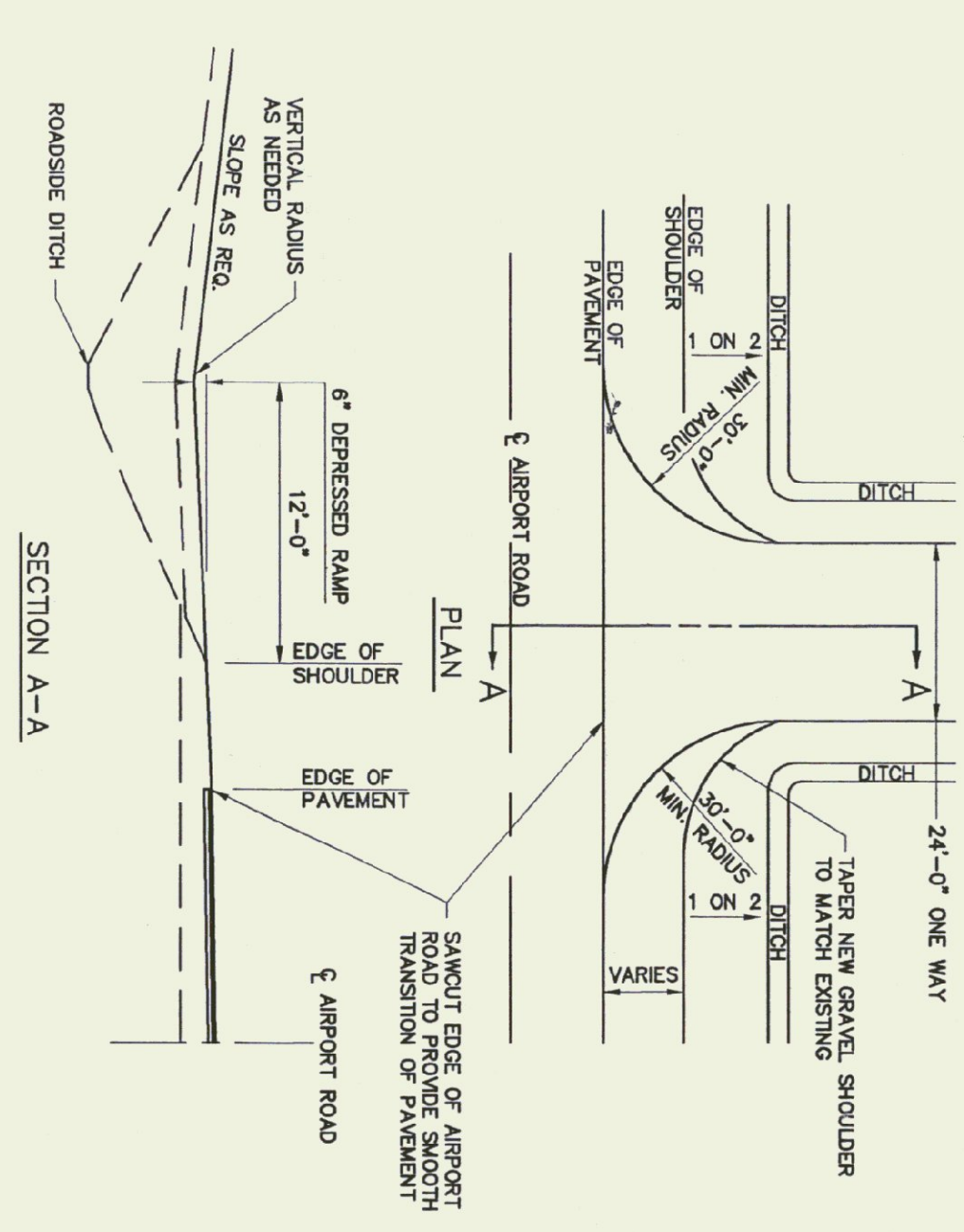

4 TYPICAL RURAL DRIVEWAY DETAIL  
N.T.S.

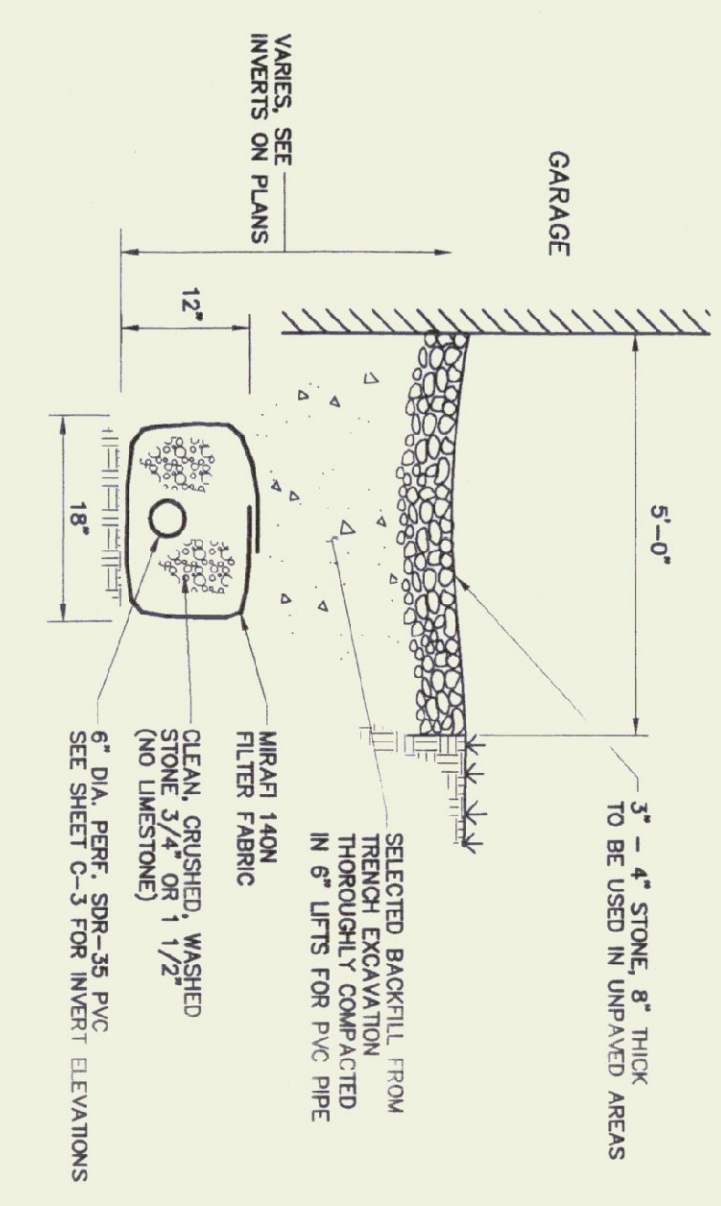

5 TYPICAL UNDERDRAIN DETAIL  
N.T.S.

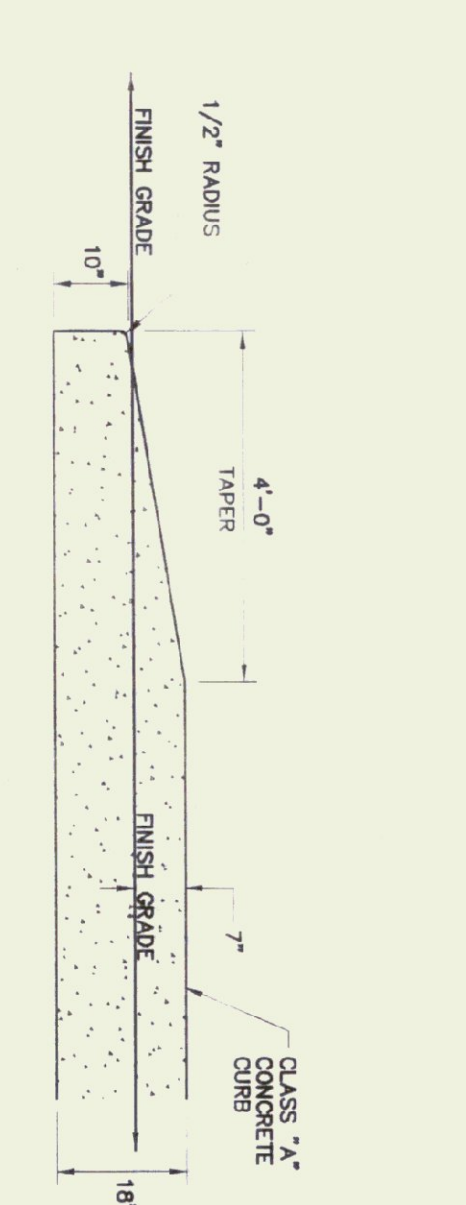

6 TYPICAL TAPERED CURB  
N.T.S.

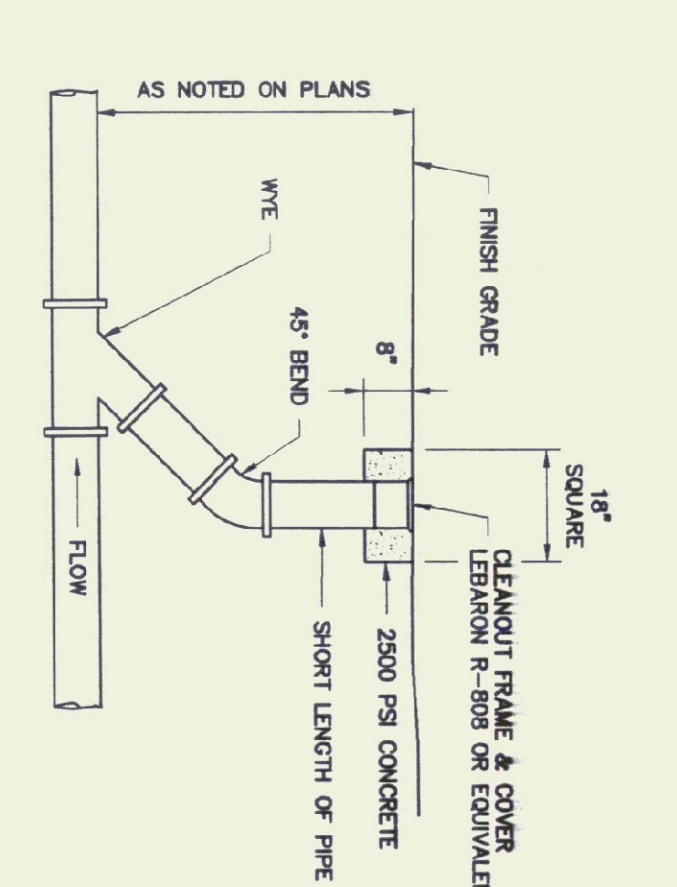

3 TYPICAL CLEANOUT DETAIL  
N.T.S.

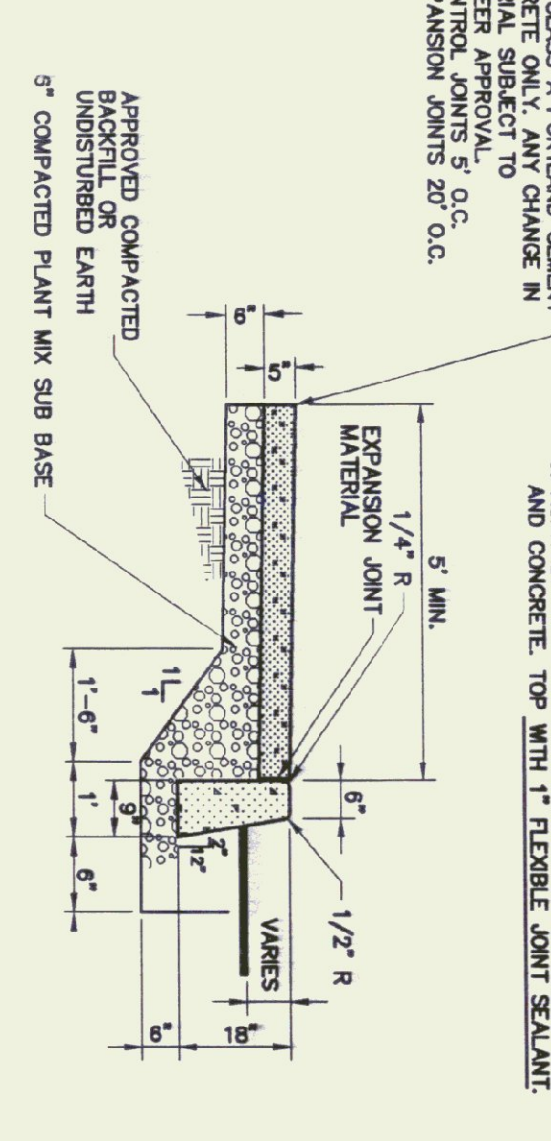

7 CONCRETE SIDEWALK & CURB DETAIL  
N.T.S.

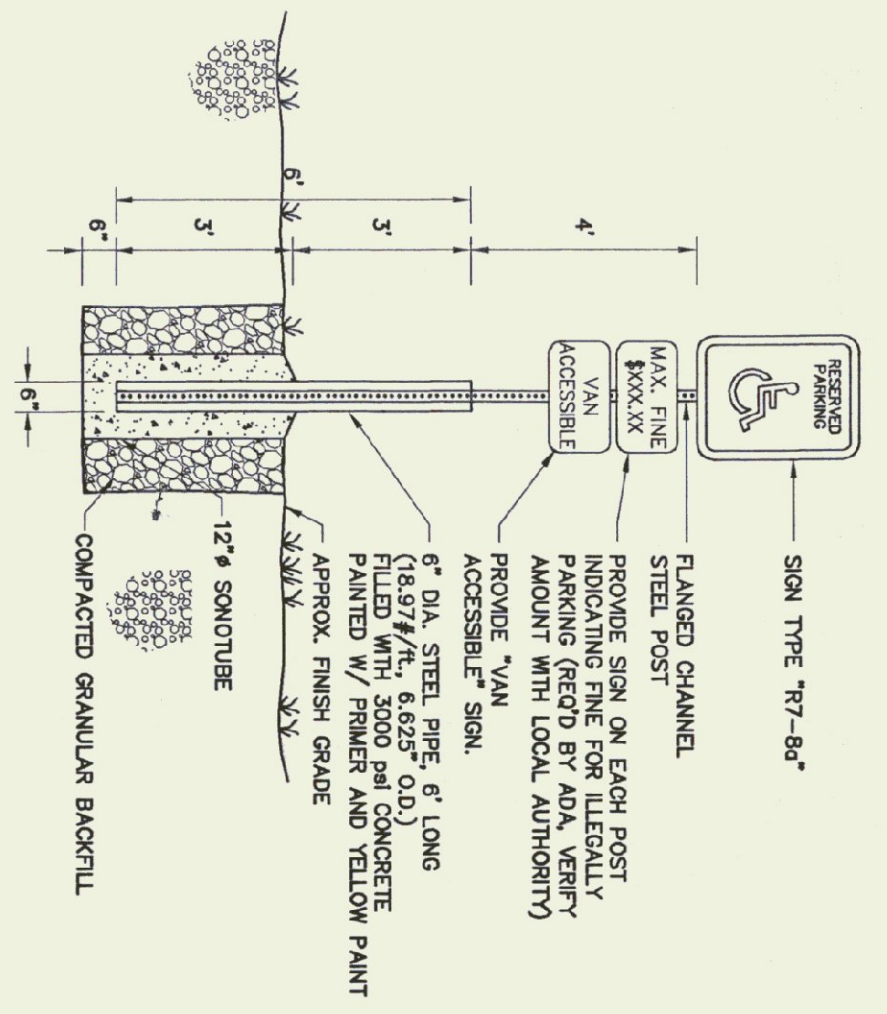

8 HANDICAP SIGN DETAIL  
N.T.S.

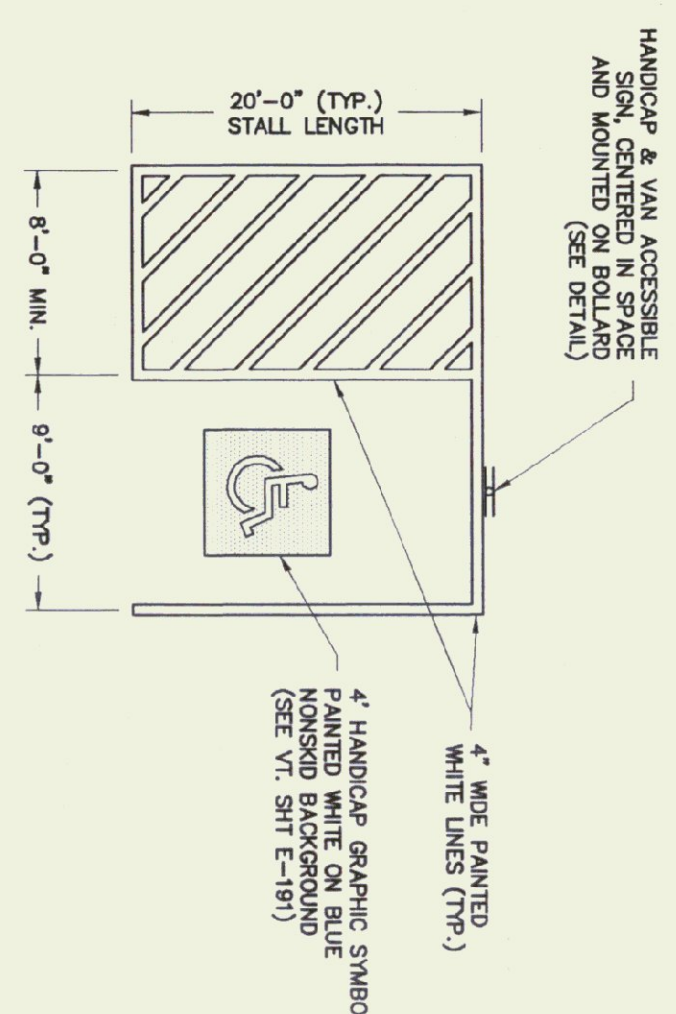

9 ACCESSIBLE SPACE PAVEMENT MARKING  
N.T.S.

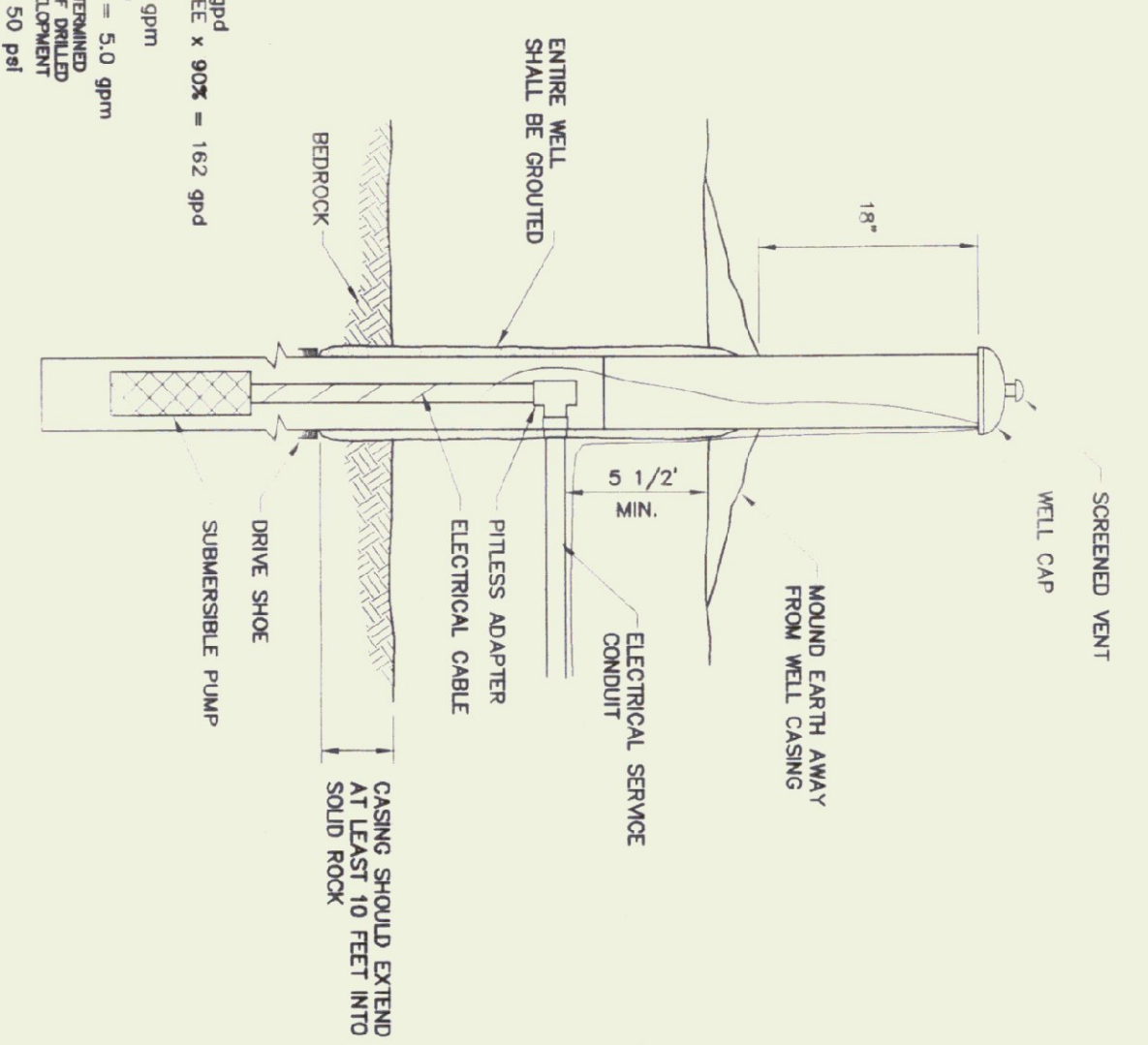

10 TYPICAL DRILLED WELL  
N.T.S.

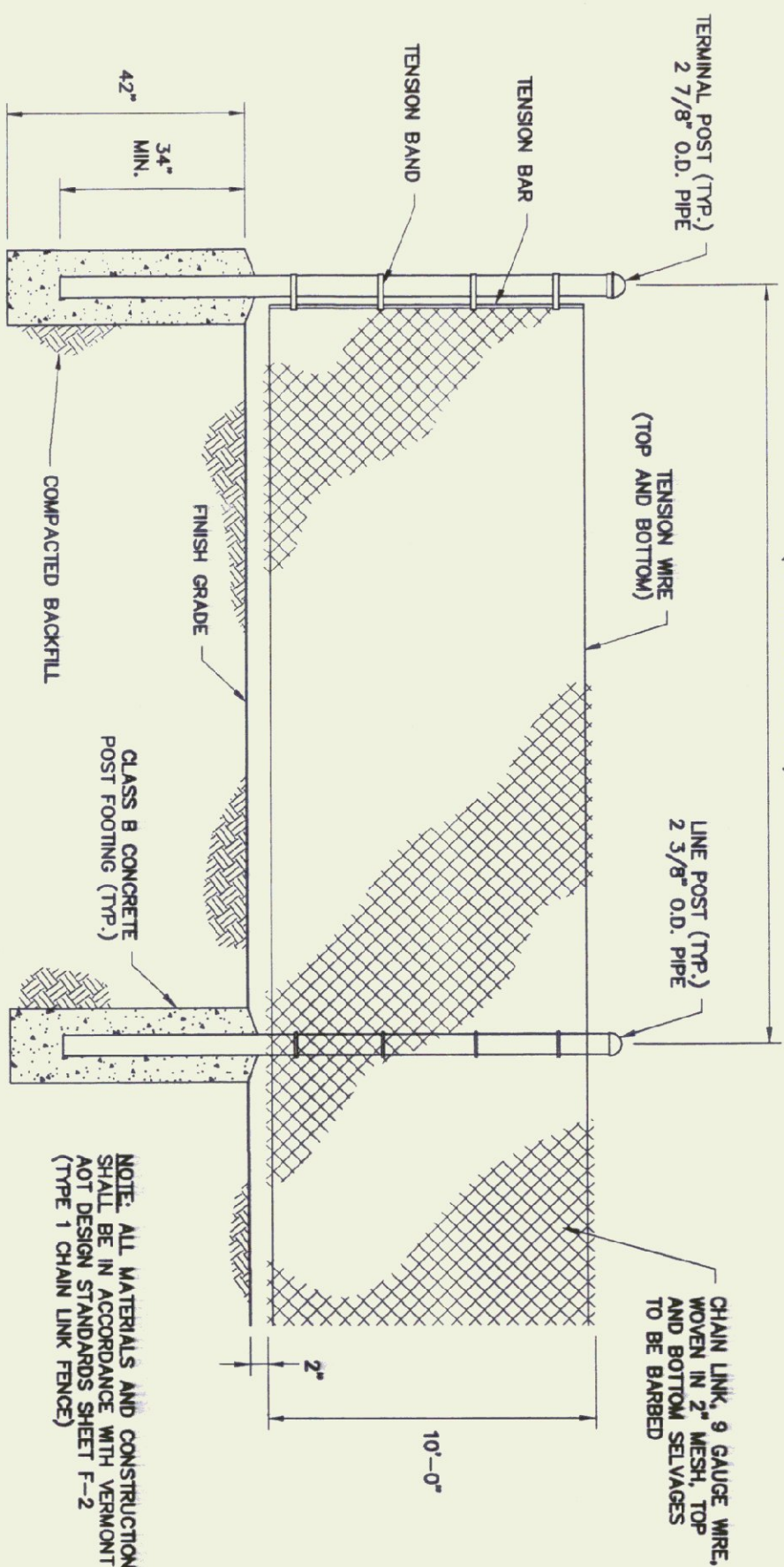

11 CHAIN LINK FENCE DETAIL  
N.T.S.

- DESIGN NOTES - WATER SUPPLY
- A) AVERAGE DAY DEMAND = 177 gpd
  - B) PEAK DAY DEMAND = 177 gpd
  - C) PEAK HOUR DEMAND = 177 gpd
  - D) MINIMUM DAY DEMAND = 0.25 gpm
  - E) MINIMUM HOUR DEMAND = 0.25 gpm
  - F) STORAGE CAPACITY = 50 gal
  - G) WELL CAPACITY = 50 gal
  - H) FLOOD PLAN = N/A

- DESIGN NOTES - WATER SUPPLY
- A) AVERAGE DAY DEMAND = 177 gpd
  - B) PEAK DAY DEMAND = 177 gpd
  - C) PEAK HOUR DEMAND = 177 gpd
  - D) MINIMUM DAY DEMAND = 0.25 gpm
  - E) MINIMUM HOUR DEMAND = 0.25 gpm
  - F) STORAGE CAPACITY = 50 gal
  - G) WELL CAPACITY = 50 gal
  - H) FLOOD PLAN = N/A

- DESIGN NOTES - WATER SUPPLY
- A) AVERAGE DAY DEMAND = 177 gpd
  - B) PEAK DAY DEMAND = 177 gpd
  - C) PEAK HOUR DEMAND = 177 gpd
  - D) MINIMUM DAY DEMAND = 0.25 gpm
  - E) MINIMUM HOUR DEMAND = 0.25 gpm
  - F) STORAGE CAPACITY = 50 gal
  - G) WELL CAPACITY = 50 gal
  - H) FLOOD PLAN = N/A



**Champlain Consulting ENGINEERS**  
85 PRIM ROAD, P.O. BOX 463 COLCHESTER, VERMONT 05440  
PHONE: (802) 893-8060 FAX: (802) 894-1878

**D&W DORE AND WHITTIER, INC.**  
1795 WILLISTON RD, STE. 5 QUINCY, MA 02169  
Phone: (617) 471-2897 Fax: (617) 471-2516

STATE OF VERMONT  
DEPARTMENT OF BUILDINGS AND GENERAL SERVICES  
AGENCY OF ADMINISTRATION  
MONTPELIER, VERMONT

AGENCY OF TRANSPORTATION  
HIGHGATE MAINTENANCE FACILITY  
HIGHGATE VERMONT

REVISIONS  
SCALE: N.T.S.  
DATE: 08/03/01  
DRAWN BY: CCE  
APPR. BY: PD

RECEIVED  
AUG 3 2001  
C-6  
6 OF 7