

CLEANOUT SHOWN IS FOR IN LINE INSTALLATION. OTHER CLEANOUT SIMILAR EXCEPT USE 2 STREET ELBOWS INTO THE END OF WYE LAYING ON ITS SIDE.

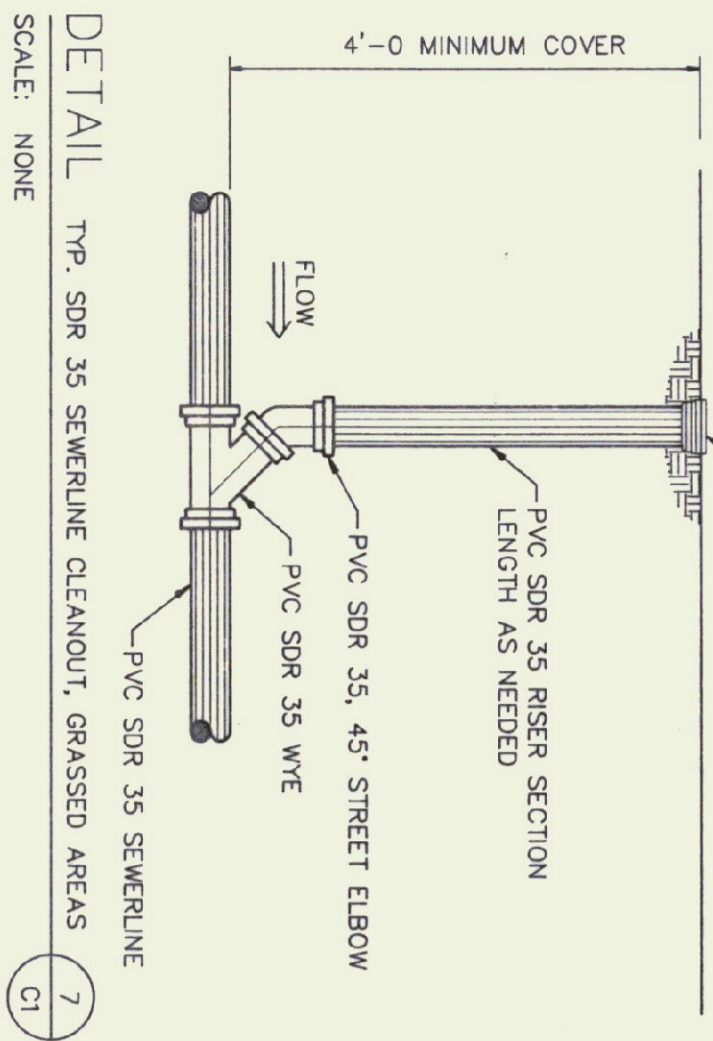

DETAIL 7  
SCALE: NONE

TOP SECTION OF VALVE BOXES FOR CLEANOUTS SHALL BE CAST IRON WITH A TOP FLANGE AND HAVE A MINIMUM INSIDE DIAMETER OF 5 1/4 INCHES. COVERS SHALL BE CAST IRON DROP-TYPE, NON TILTING AND RECESSED TO PREVENT FLOW BREAKAGE.

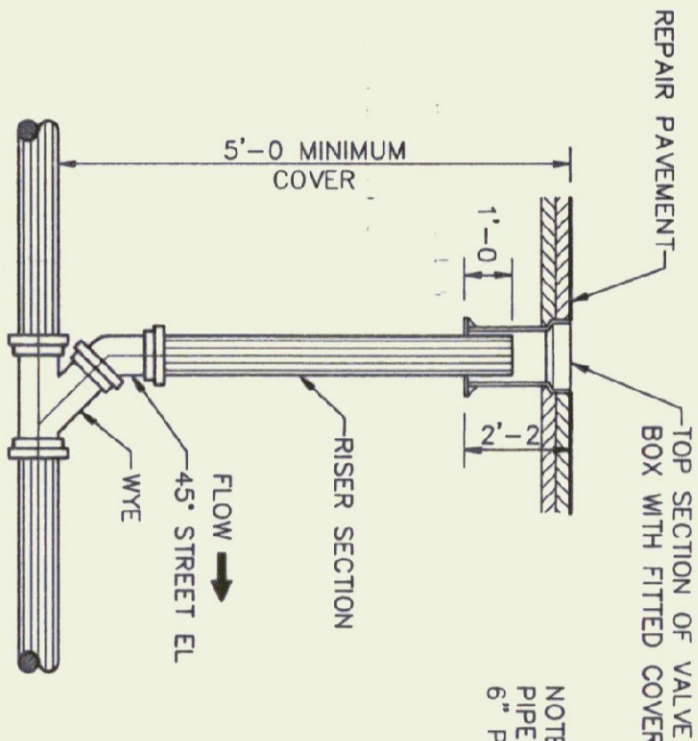

DETAIL 8  
SCALE: NONE

CENTRELINE OF SVALE

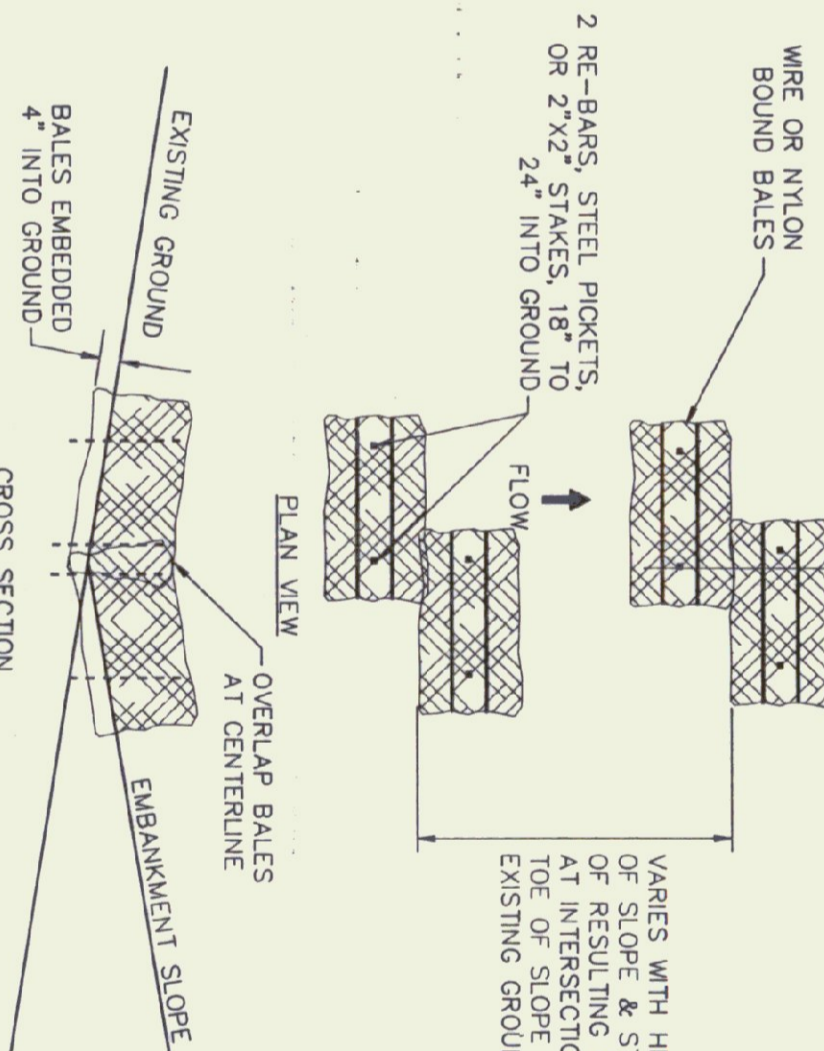

DETAIL 9  
SCALE: NONE

6\"/>

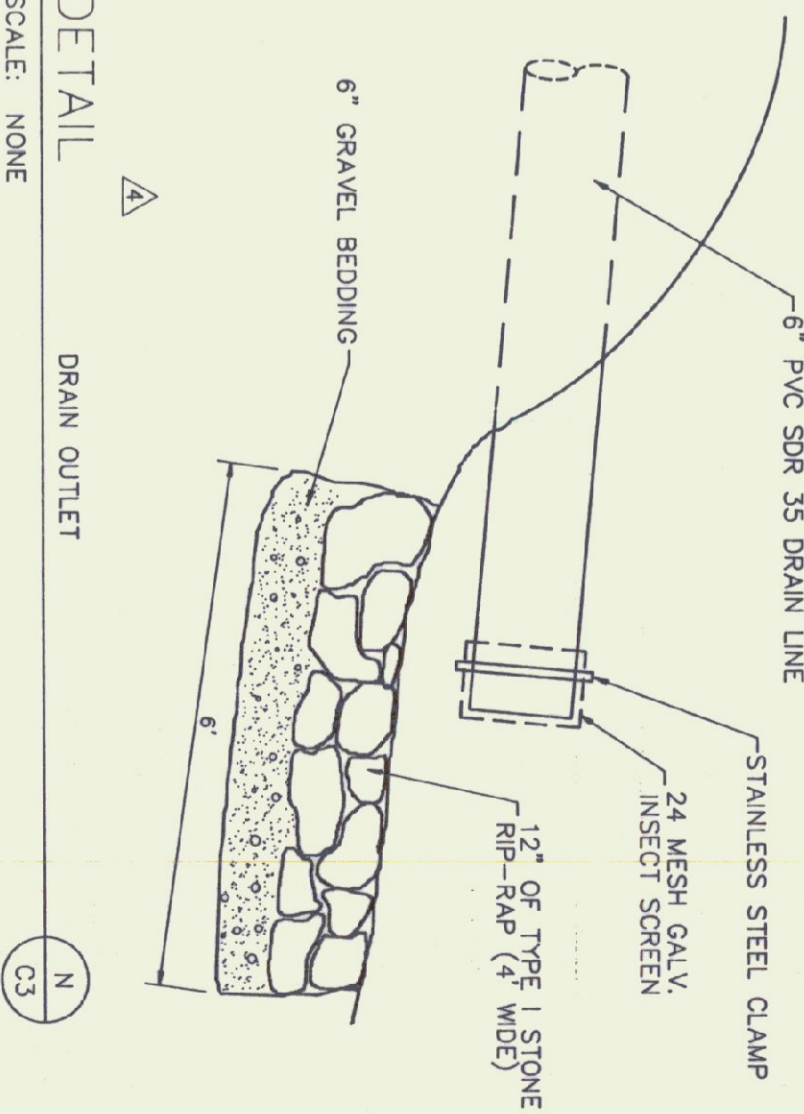

DETAIL 10  
SCALE: NONE

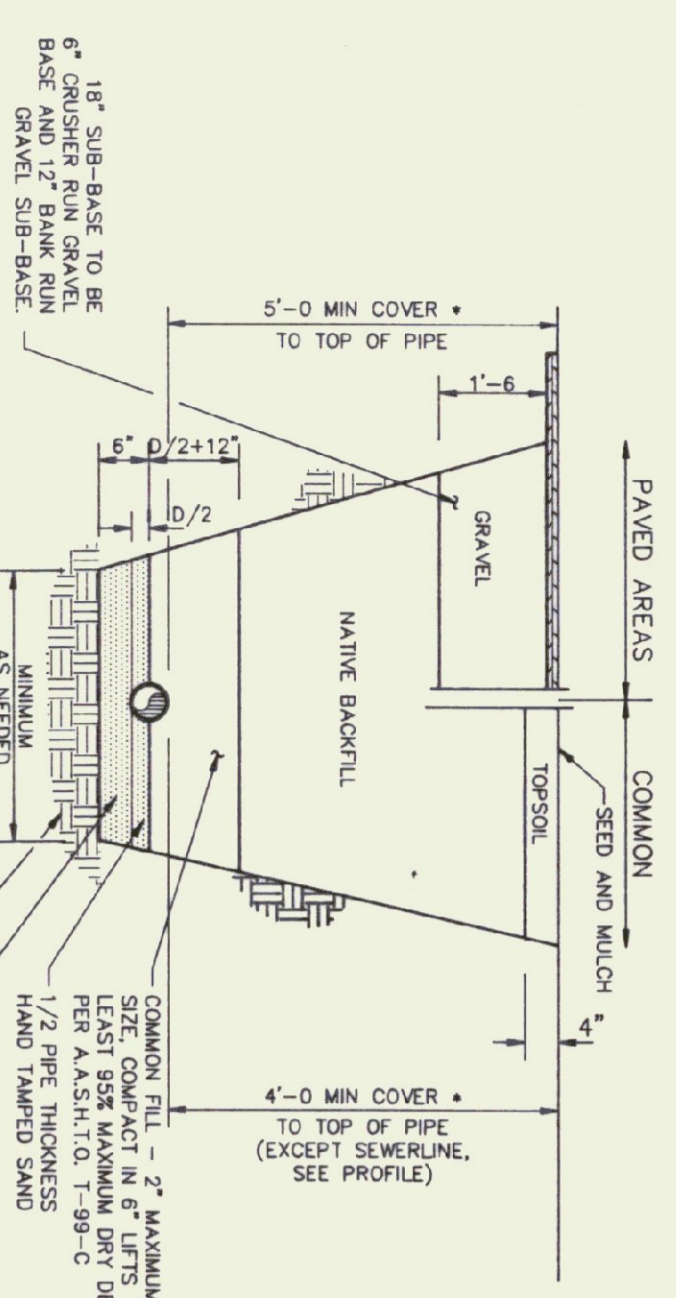

SECTION 10  
SCALE: NONE

1. GRAVEL: ALL GRAVEL AND CRUSHED GRAVEL FOR SUB-BASE USE SHALL CONFORM TO ASTM SPECIFICATION 406 - BITUMINOUS CONCRETE PAVEMENT TO 4\"/>

2. SURGRADE: CONSTRUCTION SHALL CONFORM TO 2012 SPECIFICATION 2012.12 - \"SURGRADE\" WITH RESPECT TO MATERIAL QUALITY AND COMPACTION.

3. SUB-BASE: SUB-BASE MATERIAL SHALL BE PLACED IN 4 LIFT LIFTS EACH COMPACTED TO AT LEAST 95% MAXIMUM DRY DENSITY (ASTM D 1557-02) AT 1\"/>

4. PAVEMENT: PAVEMENT SHALL CONSIST OF TWO BITUMINOUS COURSES, CONFORMING TO 2012 SPECIFICATION 2012.12 - \"SURGRADE\" WITH RESPECT TO MATERIAL QUALITY AND COMPACTION.

5. SAND - SAND SHALL CONFORM TO 2012 SPEC 703.03 - \"SAND BORROW AND DISMISH\".

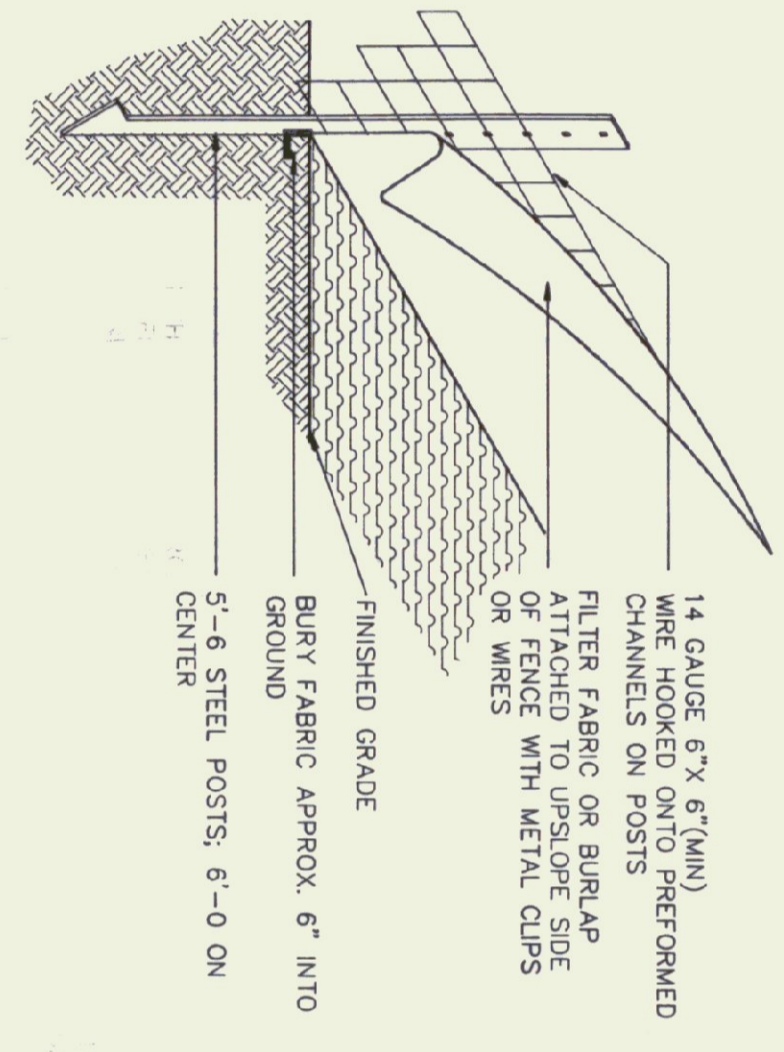

DETAIL 11  
SCALE: NONE

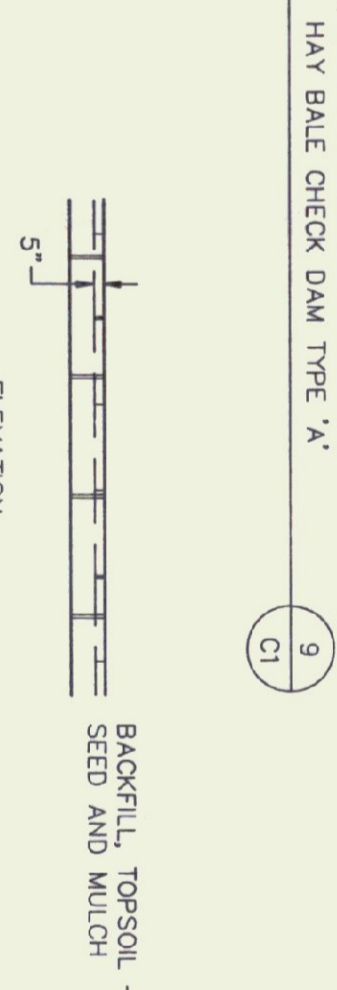

DETAIL 14  
SCALE: NONE

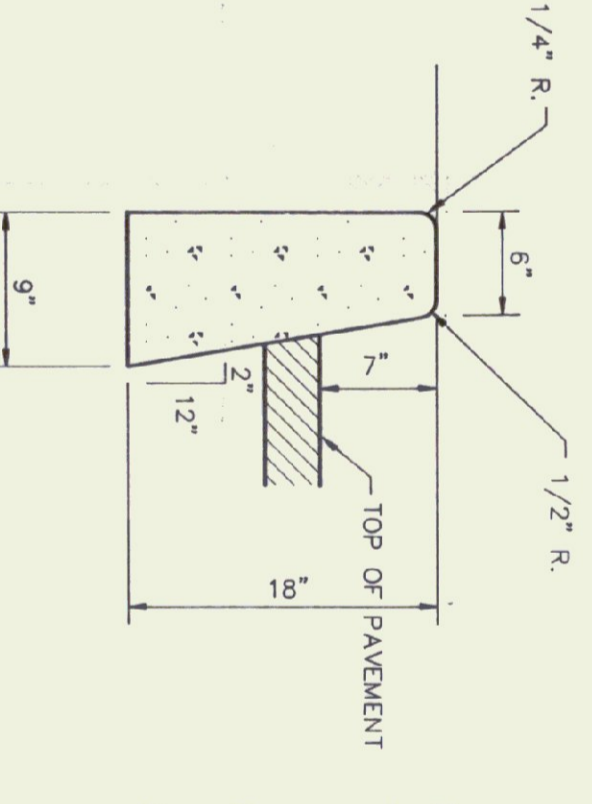

DETAIL 15  
SCALE: NONE

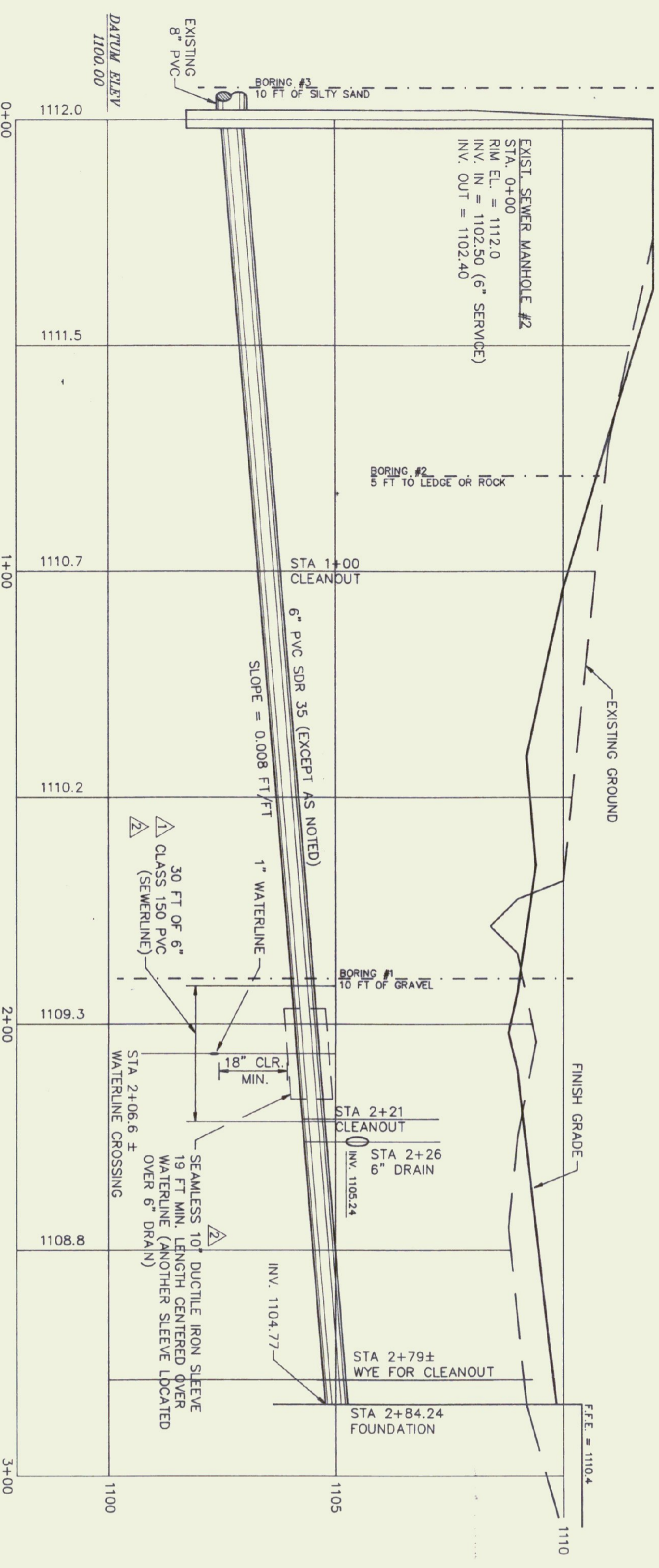

PROFILE 12  
SCALE: 1\"/>

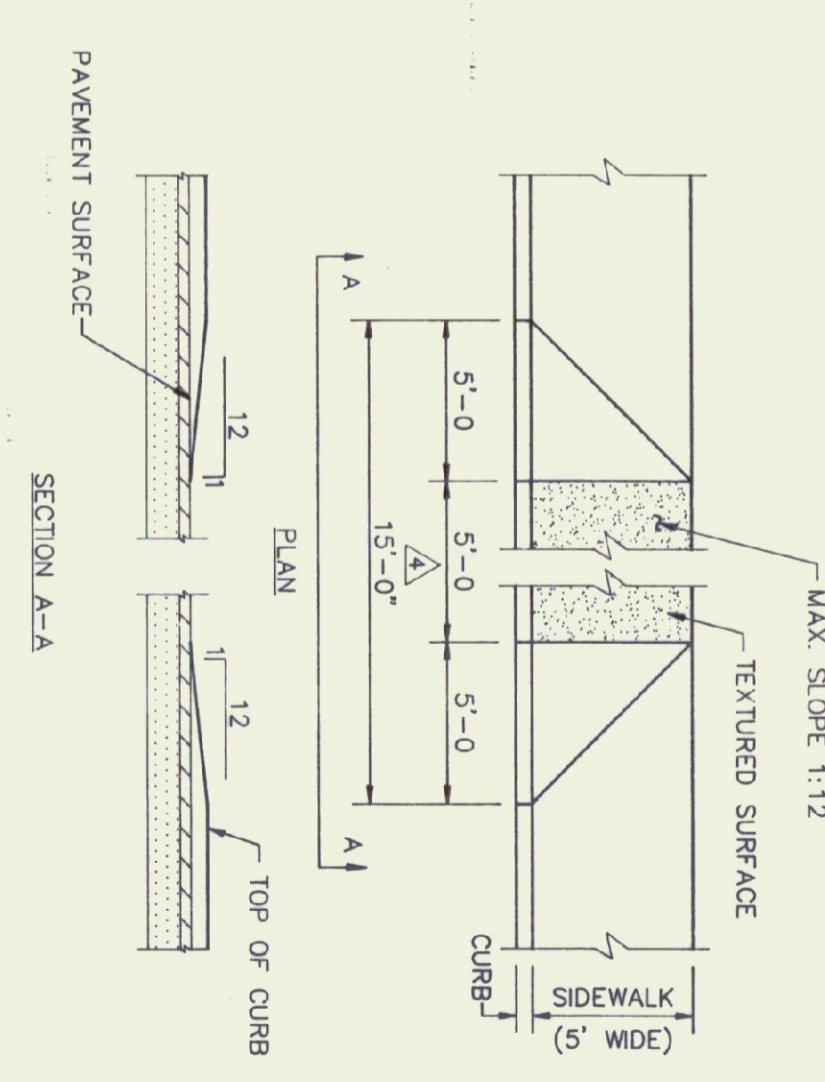

DETAIL 16  
SCALE: NONE

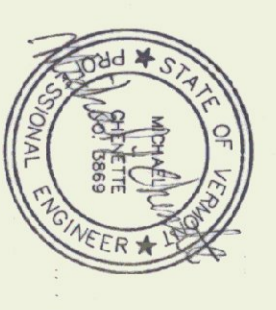

**Gossens Bachman**  
Architecture and Interior Design

Gossens Bachman, Inc.  
100 Main Street  
Montpelier, Vermont 05602  
(802) 229-1644

**CEI**  
Chenette  
Engineering, Inc

7 Main Street  
Montpelier, Vermont 05602  
(802) 229-1442

Project Title:  
**Agency of Transportation:  
Huntington  
Hangar**  
Berlin, Vermont  
AIP-04-9076

Revisions:

- 19 FEB 1993  
SEWER LINE MATERIALS CHANGE
- 26 FEB 1993  
WATER LINE CLEARANCE
- 3 JULY 1995  
PPE STEPS SIDE & CURB CUT REV.
- 19 OCT 1995  
SDI SEWER, GEMAS AND STEPS V/C3

Job Number:  
Drawn By: CEI  
Checked By: CEI  
Scale: as noted  
Date Nov. 11, 1992  
Sheet Title:

**Sections  
Details**

Sheet Number:  
**C3**

@Gossens Bachman, Inc.