

# TOWN OF COLCHESTER, VERMONT

## FORT ETHAN ALLEN

# STORMWATER IMPROVEMENTS

VTRANS PROJECT #SSMG 003-100

GRANT #SW003

### VERMONT AGENCY OF TRANSPORTATION

STANDARD	DATE
B-5	6-01-94
B-71	7-08-05
D-4	8-13-07
D-15	6-01-94
D-16	6-01-94
E-100	1-02-04
E-100A	1-02-04
E-101	5-30-03
E-102	6-30-03
E-102A	5-01-04
E-106	3-01-04
F-4	6-01-94

LOCATED ON A PARCEL OF LAND ALONG THE WEST SIDE OF TROY AVENUE AND ADJACENT TO VERMONT PUBLIC RADIO IN THE FORT ETHAN ALLEN COMPLEX IN COLCHESTER, VERMONT. THE PROJECT INCLUDES THE CONSTRUCTION OF A NEW MICROPOOL EXTENDED DETENTION STORMWATER POND WITH NEW DRAINAGE PIPING, A GRAVEL ACCESS DRIVE AND RELATED WORK.

THESE PLANS ARE SUBJECT TO SUCH ENGINEERING CHANGES AS MAY BE REQUIRED BY THE FEDERAL HIGHWAY ADMINISTRATION OR THE COLCHESTER TOWN ENGINEER. CONSTRUCTION IS TO BE CARRIED ON IN ACCORDANCE WITH THESE PLANS AND THE STANDARD SPECIFICATIONS FOR CONSTRUCTION DATED 2006, AS APPROVED BY THE FEDERAL HIGHWAY ADMINISTRATION ON JUNE 15, 2006 FOR USE ON THIS PROJECT, INCLUDING ALL SUBSEQUENT REVISIONS AND SUCH REVISED SPECIFICATIONS AND SPECIAL PROVISIONS AS ARE INCORPORATED IN THESE PLANS.

### SELECT BOARD

DICK PAQUETTE, CHAIR  
 MARC LANDRY  
 EDWARD PLOOF, JR.  
 ROGER DERBY  
 BRIAN MCNEIL

### TOWN MANAGER

AL VOEGELE

### DIRECTOR OF PUBLIC WORKS

BRYAN K. OSBORNE

### TOWN ENGINEER

FLOYD SHEESLEY, P.E.

### TOWN CLERK

KAREN RICHARD



PROJECT AREA

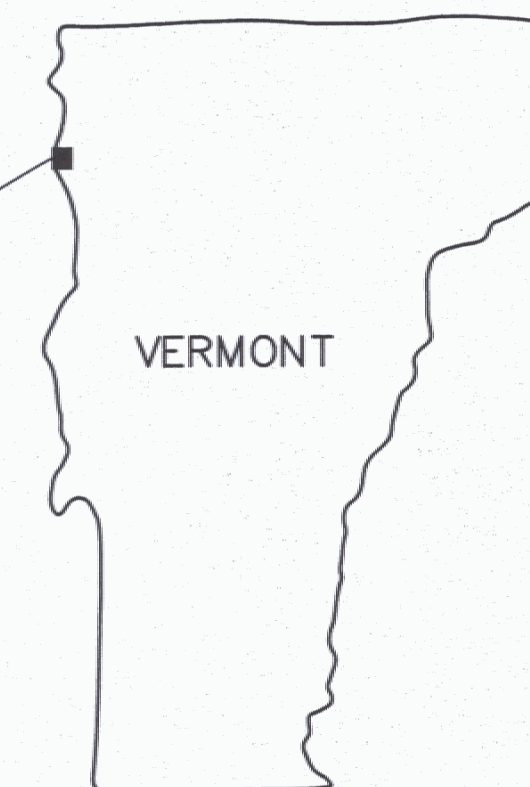

### INDEX OF DRAWINGS

SHEET	DRAWING NO.	TITLE
1	T	TITLE SHEET AND INDEX OF DRAWINGS
2	1	GENERAL CONSTRUCTION NOTES AND LEGEND
3	2	EXISTING SITE AND DEMOLITION PLAN
4	3	PROPOSED DETENTION POND PLAN
5	3A	EPSCP CONSTRUCTION PLAN
6	4	PROPOSED DETENTION POND PROFILES
7	5	STORM DRAIN AND LANDSCAPING DETAILS
8	6	EROSION CONTROL DETAILS

FUNDING ASSISTANCE FOR THIS PROJECT IS BEING FURNISHED BY USEPA STAG GRANT, STATE OF VERMONT STORMWATER IMPROVEMENT RESTORATION FUND, VTRANS AND FHWA.

### TOWN APPROVAL:

AL VOEGELE, AUTHORIZED REPRESENTATIVE

DATUM	
VERTICAL	NAVD 1988
HORIZONTAL	NAD 1983

**PROGRESS PRINT**

MAR 27 2008

CIVIL & ENVIRONMENTAL ENGINEERS  
 6 Market Place, Suite 2  
 Essex Jct., VT 05452  
 P: 802.878.7733  
 F: 802.878.1742

**FA & A**  
 FORCIER & ALDRICH & ASSOCIATES

TOWN OF COLCHESTER  
 COLCHESTER, VERMONT

FORT ETHAN ALLEN  
 STORMWATER IMPROVEMENTS

TITLE SHEET AND  
 INDEX OF DRAWINGS

JJD	CHECKED
TOWN AND L&D COMMENTS	REVISION DESCRIPTION
3/08	DATE
NO.	

DESIGNED RM	PROJECT NO. 07037
DRAWN JEB	DRAWING NO. T
CHECKED JJD	
DATE OCT. 2007	SHEET 1

**LEGEND FOR ALL DRAWINGS**

**GENERAL CONSTRUCTION NOTES**

**PLAN**

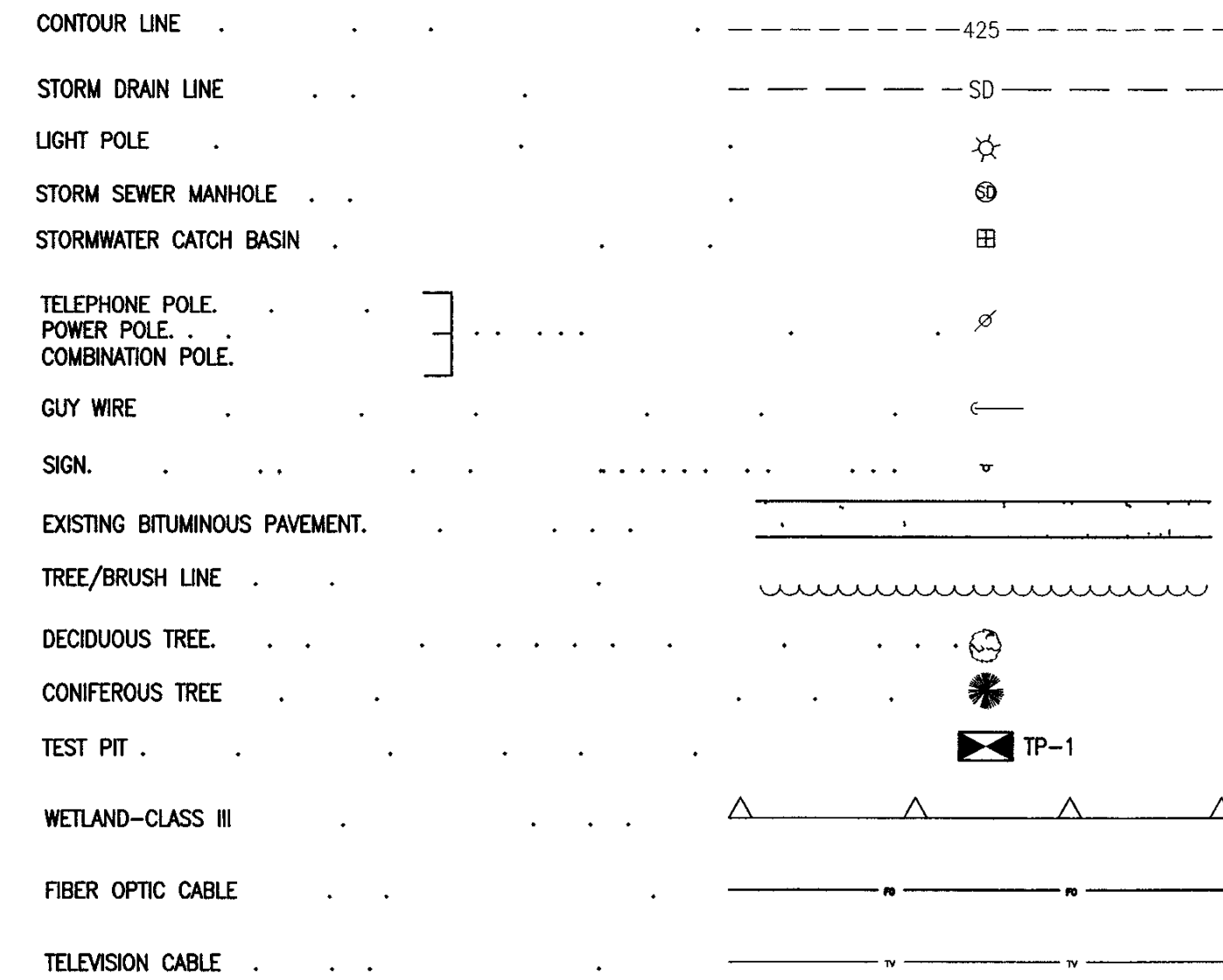

**PLAN**

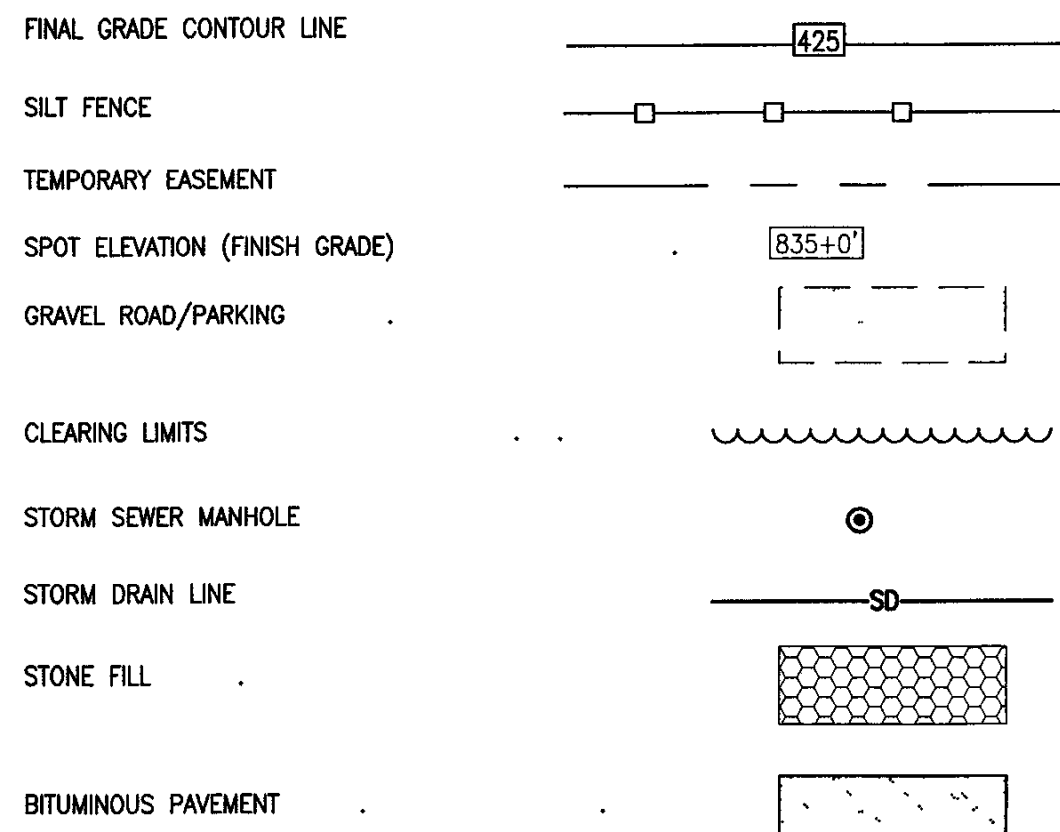

**1 SAFETY**

- A. THE CONTRACTOR SHALL TAKE ALL NECESSARY PRECAUTIONS FOR THE SAFETY OF EMPLOYEES ON THE PROJECT AND SHALL COMPLY WITH ALL APPLICABLE PROVISIONS OF FEDERAL, STATE AND LOCAL SAFETY LAWS AND BUILDING CODES TO PREVENT ACCIDENTS OR INJURY. THE CONTRACTOR SHALL ERECT AND PROPERLY MAINTAIN AT ALL TIMES ALL NECESSARY SAFEGUARDS AND BARRICADES FOR THE PROTECTION OF EMPLOYEES ON THE WORK AND SAFETY OF OTHERS EMPLOYED NEAR THE WORK AND THE PUBLIC. FURTHER, THE CONTRACTOR SHALL POST DANGER SIGNS AND OTHER WARNING DEVICES TO PROTECT INDIVIDUALS FROM BEING INJURED IN THE VICINITY OF THE WORK.
- B. THE CONTRACTOR SHALL COMPLY WITH ALL APPLICABLE O.S.H.A. SAFETY REQUIREMENTS. THE CONTRACTOR SHALL INSURE ALL WORK PROCEEDS IN ACCORDANCE WITH O.S.H.A. REQUIREMENTS FOR SAFETY TRENCHING, EXCAVATION, AND CONFINED SPACE ENTRY PROCEDURES.
- C. THE CONTRACTOR SHALL PROVIDE ADEQUATE EQUIPMENT AND FACILITIES AS ARE NECESSARY AND REQUIRED TO PROVIDE EMERGENCY FIRST AID TO ANY PERSON WHO MAY BE INJURED IN THE PROSECUTION OF THE WORK UNDER THIS CONTRACT.

**2 PROTECTION OF WORK**

- A. THE CONTRACTOR SHALL ASSUME FULL RESPONSIBILITY FOR THE PROTECTION OF ALL BUILDINGS, STRUCTURES AND UTILITIES (BOTH PUBLIC AND PRIVATE), INCLUDING POWER POLES, SIGNS, UTILITY SERVICES, WATER MAINS, HYDRANTS, SEWERS, FORCE MAINS, STORM DRAINS, BURIED ELECTRICAL OR CONTROL WIRES, AND TELEPHONE CABLES WHETHER OR NOT THEY ARE SHOWN ON THE CONTRACT DRAWINGS.
- B. THE CONTRACTOR SHALL CAREFULLY SUPPORT AND PROTECT ANY UTILITIES, STRUCTURES, PIPE LINES, AND CONDUITS WHICH MAY BE ENCOUNTERED DURING COMPLETION OF THE WORK. ANY DAMAGE RESULTING FROM THE CONTRACTOR'S OPERATIONS SHALL BE REPAIRED BY HIM TO THE SATISFACTION OF THE CONSTRUCTION ENGINEER AT CONTRACTOR'S EXPENSE.

**3 BURIED UTILITIES**

- A. THE CONTRACTOR SHALL NOTIFY "DIG SAFE" AT 1-888-DIG-SAFE 2 WEEKS PRIOR TO EXCAVATING IN CONSTRUCTION AREAS IN ORDER TO LOCATE BURIED UTILITIES WHICH MAY OR MAY NOT BE PRESENT. NO EXCAVATION IS AUTHORIZED UNTIL AFTER DIG SAFE HAS MARKED ALL EXISTING UTILITIES.
- B. UNDERGROUND UTILITIES LOCATIONS ARE APPROXIMATE ONLY THOSE SHOWN ON THE DRAWINGS ARE BASED ON THE BEST AVAILABLE INFORMATION PRIOR TO CONSTRUCTION. THE CONTRACTOR SHALL NOTIFY OWNERS OF ADJACENT UTILITIES WHEN PROSECUTION OF THE WORK MAY AFFECT THEM. ALL DAMAGE, INJURY OR LOSS TO ANY PROPERTY, BY THE CONTRACTOR, OR ANY SUB-CONTRACTOR, TO THE FAULT OR NEGLIGENCE OF THE CONTRACTOR, SHALL BE REPLACED OR RESTORED TO AT LEAST ORIGINAL CONDITION AT THE CONTRACTOR'S EXPENSE. THE CONTRACTOR'S DUTIES AND RESPONSIBILITIES FOR THE SAFETY AND PROTECTION OF THE WORK SHALL CONTINUE UNTIL SUCH TIME AS ALL THE WORK IS COMPLETED AND THE CONSTRUCTION ENGINEER HAS ISSUED A NOTICE TO THE OWNER AND THE CONTRACTOR AS DESCRIBED HEREIN THAT WORK IS ACCEPTABLE AND FOR A PERIOD OF TWELVE MONTHS THEREAFTER.
- C. THE CONTRACTOR SHALL EXCAVATE TEST PITS AS REQUIRED TO LOCATE EXISTING UTILITIES. THESE SHALL BE EXCAVATED TO LOCATE BURIED UTILITIES AND TO DETERMINE EXACT LOCATIONS AND/OR MATERIALS OF EXISTING UTILITIES. SOME HAND EXCAVATION MAY BE NECESSARY TO PROTECT UTILITIES. TEST PITS SHALL BE EXCAVATED AT LEAST TWO (2) WEEKS PRIOR TO CONSTRUCTION OF A PARTICULAR ITEM OF WORK SO THAT DESIGN REVISIONS MAY BE MADE IF REQUIRED. ALL TEST PITS REQUIRED OR NECESSARY BY THE CONTRACTOR SHALL BE INCLUDED IN THE LUMP SUM BID ITEM.
- D. THE CONTRACTOR IS RESPONSIBLE FOR ALL DAMAGE TO EXISTING UTILITIES AND SHALL BE RESPONSIBLE FOR REPAIR OF ANY SUCH DAMAGE AS QUICKLY AS POSSIBLE AT HIS OWN EXPENSE. THE CONTRACTOR SHALL MAINTAIN A SUPPLY OF REPAIR MATERIALS AND PIPE ON THE JOB SITE AT ALL TIMES IN ORDER TO MINIMIZE THE INCONVENIENCE CAUSED BY SUCH DAMAGE.

**5 CONSTRUCTION**

- A. THE CONTRACTOR SHALL USE ONLY DESIGNATED BENCH MARKS FOR REFERENCE ELEVATIONS.
- B. EROSION CONTROL, SHALL BE PROVIDED BY THE CONTRACTOR, IN ACCORDANCE WITH CONTRACT DOCUMENTS. EROSION CONTROLS SHALL BE IN PLACE PRIOR TO CONSTRUCTION. ALL DISTURBED AREAS ARE TO BE IMMEDIATELY STABILIZED.

**6 SITEMARK**

- A. ALL EXCESS MATERIAL SHALL BE DISPOSED OF OFF SITE UNLESS APPROVED BY THE OWNER. A COPY OF A WRITTEN AGREEMENT BETWEEN THE CONTRACTOR AND THE SITE OWNER SHALL BE SUBMITTED TO THE CONSTRUCTION ENGINEER BEFORE ANY MATERIAL IS DEPOSITED AT THE SITE. DISPOSAL OF EXCESS MATERIALS OFF-SITE SHALL BE PERFORMED IN ACCORDANCE WITH SOLID WASTE MANAGEMENT DIVISION REGULATIONS AND SHALL INCLUDE THE OBTAINING OF ANY REQUIRED PERMITS. VTRANS WILL REVIEW AND PERMIT ALL WASTE, BORROW AND STAGING SITES OF THE CONTRACTOR BEFORE CONSTRUCTION CAN BEGIN.
- B. IN AREAS WHERE NEW DRAINAGE STRUCTURES ARE TO BE INSTALLED, EXISTING SUBGRADE SOILS MUST BE EXAMINED BY THE CONSTRUCTION ENGINEER TO DETERMINE THE NEED FOR ADDITIONAL EXCAVATION OR COMPACTION PRIOR TO CONSTRUCTION.

**7 RECORD DOCUMENTS**

- A. ALL BURIED UTILITIES ENCOUNTERED SHALL BE DOCUMENTED WITH DEPTH AND THREE (3) TIES AND SHOWN BY THE CONTRACTOR ON RECORD DRAWINGS.

**8 STANDARDS**

- A. USE STATE OF VERMONT, AGENCY OF TRANSPORTATION, STANDARD SPECIFICATIONS FOR CONSTRUCTION, LATEST EDITION.

**9 EROSION PREVENTION AND SEDIMENT CONTROL PLAN**

- A. THE EROSION PREVENTION AND SEDIMENT CONTROL PLAN IS INCLUDED IN APPENDIX B OF THE PROJECT SPECIFICATIONS. THE PLAN SHALL BE IMPLEMENTED PRIOR TO, DURING, AND AT THE CONCLUSION OF CONSTRUCTION.

**10 REFERENCE PLANS**

- A. PLANS ENTITLED "FORT ETHAN ALLEN STORMWATER IMPROVEMENTS" DATED JUNE 19, 2006, DRAWING No. 1, SITE PLAN, AS PREPARED BY DONALD L. HAMLIN CONSULTING ENGINEERS, INC.
- B. SURVEY INFORMATION OBTAINED FROM DONALD L. HAMLIN CONSULTING ENGINEERS, INC. IS BASED ON NAD83 AND NAVD88 AND USES NGS BENCHMARKS PG1426 AND AB9622.

CIVIL & ENVIRONMENTAL ENGINEERS

6 Market Place, Suite 2  
Essex Jct., VT 05452  
P 802 879 7733  
F 802 879 1742

**FA & A**

FORCIER  
ALDRICH &  
ASSOCIATES

TOWN OF COLCHESTER  
COLCHESTER, VERMONT

FORT ETHAN ALLEN  
STORMWATER IMPROVEMENTS

GENERAL  
CONSTRUCTION NOTES  
AND LEGEND

NO	REVISION DESCRIPTION	DATE	CHECKED
1		3/08	JJD

DESIGNED	PROJECT NO
RM	07037
DRAWN	DRAWING NO
JEB	1
CHECKED	DATE
JJD	OCT 2007
SHEET	2

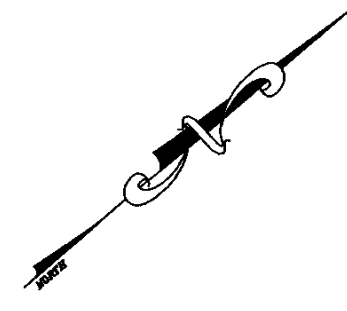

N/F UNITED STATES OF AMERICA

N/F STATE OF VERMONT

N/F VERMONT PUBLIC RADIO

TROY AVENUE

100'x200' TEMPORARY EASEMENT LIMIT

STAGING AREA (SEE NOTE 3)

N/F ST MICHAELS COLLEGE LOT #20-004000

N/F TROWELL TRADES

PLAN SCALE 1"=30'

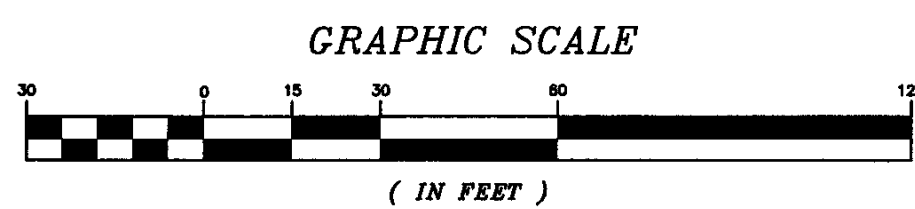

- DEMOLITION NOTES:
- REFER TO THE EROSION CONTROL NOTES ON DRAWING No 6
  - THE EROSION PREVENTION AND SEDIMENT CONTROL PLAN IS IN APPENDIX B OF THE PROJECT SPECIFICATIONS THE PLAN SHALL BE IMPLEMENTED PRIOR TO, DURING, AND AT THE CONCLUSION OF CONSTRUCTION
  - CONTRACTOR IS PERMITTED TO USE THE STAGING AREA FOR MATERIAL, STOCKPILE, EQUIPMENT, STAGING, ETC CONTRACTOR IS RESPONSIBLE FOR IMPLEMENTING EROSION CONTROL DURING CONSTRUCTION AND RETURNING STAGING AREA TO PRE-CONSTRUCTION CONDITION

CIVIL & ENVIRONMENTAL ENGINEERS

FA&A

6 Market Place, Suite 2  
Essex Jct., VT 05452  
P. 802.879.7733  
F. 802.879.1742

FORCIER  
ALDRICH &  
ASSOCIATES

TOWN OF COLCHESTER  
COLCHESTER, VERMONT

FORT ETHAN ALLEN  
STORMWATER IMPROVEMENTS

3/08 DATE	TOWN AND L&D COMMENTS	REVISION DESCRIPTION	JJD CHECKED

DESIGNED RM	PROJECT NO 07037
DRAWN JEB	DRAWING NO 2
CHECKED JJD	
DATE OCT. 2007	SHEET 3

cc:\projects\_2\07037-COLCHESTER\dwg\07037-SITE.dwg, 3/11/2008 3:53:53 PM



**LEGEND**

- EXISTING**
- NRCS SOIL BOUNDARY. ————
  - PROPERTY LINE . . . . . PL
  - CONTOUR LINE . . . . . 425
  - STORM DRAIN LINE . . . . . SD
  - LIGHT POLE . . . . . ☆
  - STORM SEWER MANHOLE . . . . . ⊙
  - STORMWATER CATCH BASIN . . . . . ⊞
  - TELEPHONE POLE . . . . . ⊕
  - POWER POLE . . . . . ⊖
  - COMBINATION POLE . . . . . ⊕⊖
  - GUY WIRE . . . . . ————
  - SIGN . . . . . ▽
  - EXISTING BITUMINOUS PAVEMENT. ————
  - TREE/BRUSH LINE . . . . . ~~~~~
  - DECIDUOUS TREE . . . . . ○
  - CONIFEROUS TREE . . . . . ⊛
  - TEST PIT . . . . . TP-1
  - WETLAND-CLASS III . . . . . ▽
  - 50' WETLAND BUFFER . . . . . ▽
  - FIBER OPTIC CABLE . . . . . ————
  - TELEVISION CABLE . . . . . ————

- PROPOSED**
- LIMITS OF DISTURBANCE . . . . . ————
  - FINAL GRADE CONTOUR LINE. . . . . 425
  - SILT FENCE . . . . . □
  - SNOW FENCE . . . . . ▽
  - TEMPORARY EASEMENT . . . . . ————
  - CLEARING LIMITS. . . . . ~~~~~
  - STONE FILL . . . . . [Pattern]
  - TEMPORARY EROSION CONTROL BLANKET . . . . . [Pattern]

- NOTES:**
1. THIS CONSTRUCTION PLAN IS DESIGNED TO CONVEY THE STEPS THAT SHALL BE TAKEN DURING CONSTRUCTION.
  2. CONTRACTOR SHALL MAINTAIN EROSION CONTROL MEASURES THROUGHOUT ALL CONSTRUCTION ACTIVITIES
  3. SEE DRAWING No 6 FOR EROSION CONTROL DETAILS
  4. THE LIMIT OF EARTH DISTURBANCE SHALL BE DEMARCATED WITH SNOW FENCE AND/OR TEMPORARY SILT FENCE
  5. FOR THE EDGE OF WETLAND SYMBOL, THE TRIANGLES POINT TOWARD THE INTERIOR OF THE WETLAND AREAS
  6. UNTIL THE FOREBAY AND CORRESPONDING MARSH AREA, OUTLET POOL AND RELATED PIPING ARE READY TO ACCEPT FLOW, ALL STORMWATER FROM EXISTING STORMWATER PIPES SHALL BE REROUTED AROUND THE CONSTRUCTION SITE AND DISCHARGED DOWNSTREAM, OUTSIDE OF ALL MAJOR CONSTRUCTION ACTIVITY AREAS
  7. DEWATER THE PROJECT SITE AS NECESSARY AND REDIRECT ALL WATER TO ON-SITE WATER HOLDING BASINS FOR SEDIMENT DEPOSIT. EFFLUENT FROM DEWATERING OPERATIONS SHALL BE FILTERED OR SHALL PASS THROUGH AN APPROVED SEDIMENT TRAPPING DEVICE PRIOR TO BEING DISCHARGED DOWNSTREAM, OUTSIDE OF THE MAJOR CONSTRUCTION ACTIVITY AREAS. CONTRACTOR SHALL SUBMIT A DEWATERING PLAN THAT MEETS THE WATER QUALITY STANDARDS TO THE CONSTRUCTION ENGINEER FOR APPROVAL AT LEAST (2) WEEKS PRIOR TO INITIATING EARTHWORK.
  8. ALL AREAS OF DISTURBANCE SHALL HAVE TEMPORARY OR FINAL STABILIZATION WITHIN 14 DAYS OF THE INITIAL DISTURBANCE. AFTER THIS TIME, ANY DISTURBANCE IN THE AREA MUST BE STABILIZED AT THE END OF EACH WORK DAY THE FOLLOWING EXCEPTIONS APPLY: i) STABILIZATION IS NOT REQUIRED IF WORK IS TO CONTINUE IN THE AREA WITHIN THE NEXT 24 HOURS AND THERE IS NO PRECIPITATION FORECAST FOR THE NEXT 24 HOURS ii) STABILIZATION IS NOT REQUIRED IF THE WORK IS OCCURRING IN A SELF-CONTAINED EXCAVATION (i.e. NO OUTLET) WITH A DEPTH OF 2 FEET OR GREATER (e.g. STRUCTURE EXCAVATION, UTILITY TRENCHES).
  9. THE SMALLEST PRACTICAL AREA OF LAND SHALL BE DISTURBED AT ANY ONE TIME DURING THE CONSTRUCTION. THE MAXIMUM AMOUNT OF EARTH DISTURBANCE AT ANY ONE TIME SHALL BE TWO (2) ACRES. REFER TO THE EROSION PREVENTION AND SEDIMENT CONTROL PLAN, RISK ASSESSMENT WHEN LAND IS DISTURBED DURING CONSTRUCTION, THE DISTURBANCE SHALL BE KEPT TO THE SHORTEST PRACTICAL DURATION AS APPROVED BY THE ENGINEER. THIS PROJECT IS NOT PERMITTED FOR WINTER CONSTRUCTION FROM OCTOBER 15th TO APRIL 15th. LAND SHALL NOT BE LEFT DISTURBED DURING THE WINTER MONTHS AND OVER WINTER STABILIZATION MEASURES SHALL BE INSTALLED PRIOR TO OCTOBER 15th.
  10. CONTRACTOR SHALL FOLLOW ALL APPLICABLE REQUIREMENTS FROM VERMONT STANDARDS AND SPECIFICATIONS FOR EROSION PREVENTION AND SEDIMENT CONTROL REGARDING PART 3.3, MINIMUM EPSC PLAN REQUIREMENTS

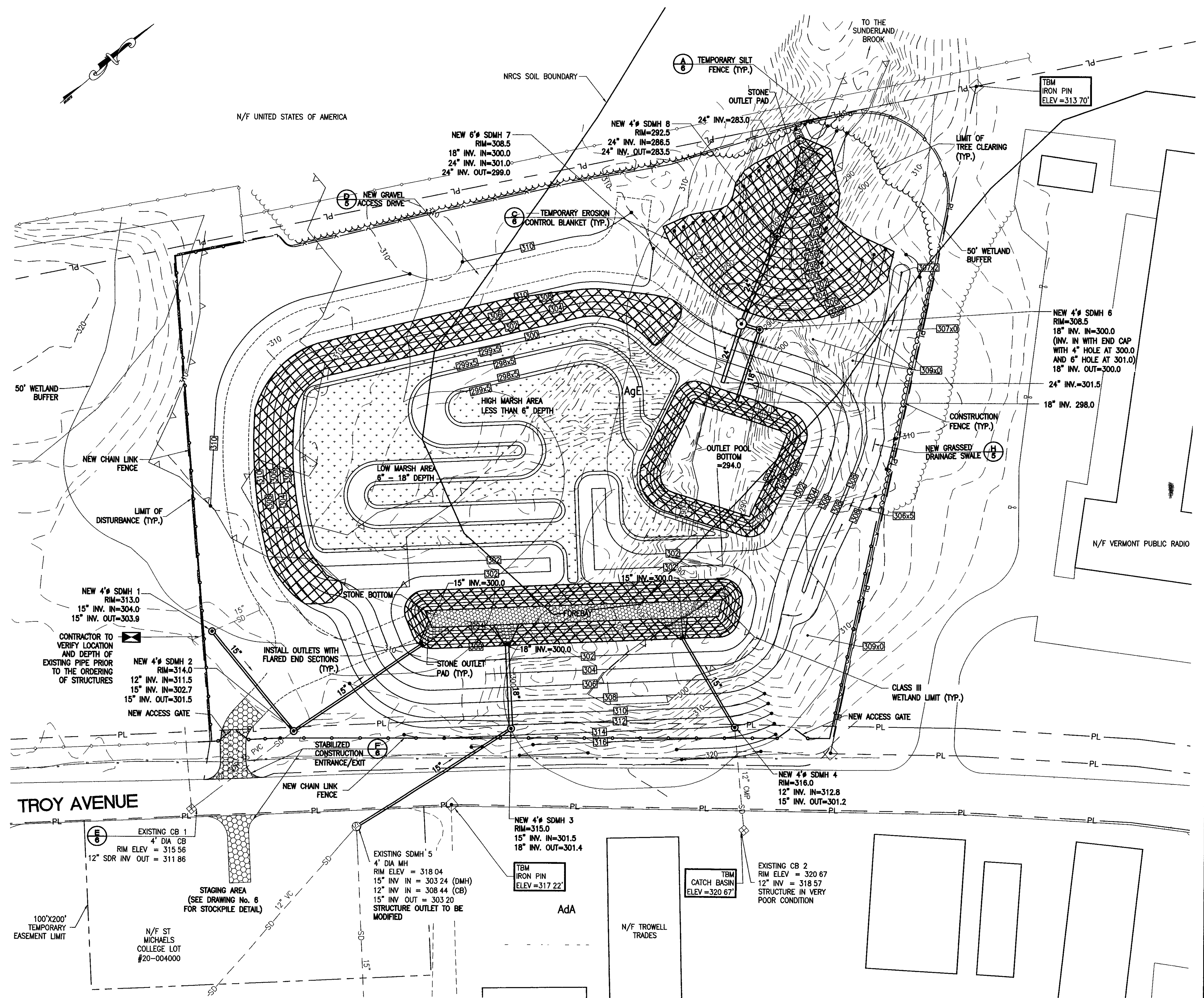
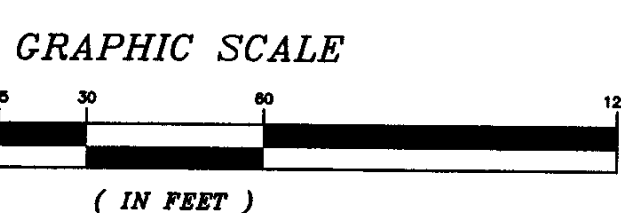

**PLAN**  
SCALE: 1"=30'

CIVIL & ENVIRONMENTAL ENGINEERS  
6 Market Place, Suite 2  
Essex Jct., VT 05452  
P. 802.879.7733  
F. 802.879.1742

**FA & A**  
FORCIER  
ALDRICH &  
ASSOCIATES

TOWN OF COLCHESTER  
COLCHESTER, VERMONT

FORT ETHAN ALLEN  
STORMWATER IMPROVEMENTS

NO.	DATE	TOWN AND L&D COMMENTS	JDD	CHECKED

**EPSCP CONSTRUCTION PLAN**

DESIGNED RM	PROJECT NO 07037
DRAWN JEN	DRAWING NO 3A
CHECKED JDD	SHEET 5
DATE OCT 2007	

\\07037-COLCHESTER\dwg\07037-3A.dwg, 3/18/2008 10:42:50 AM

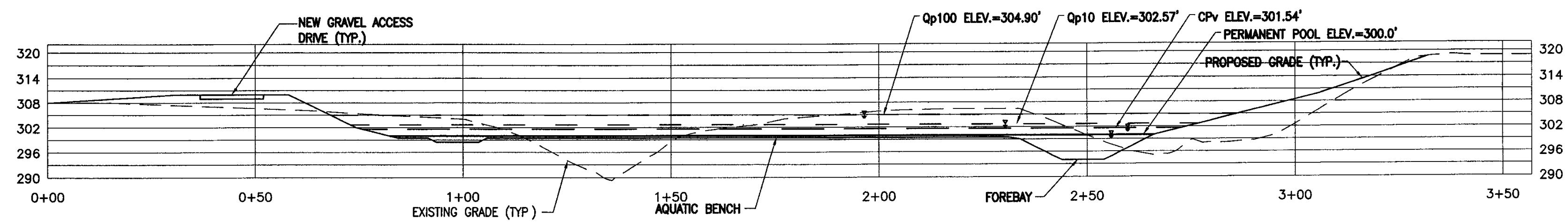

**A PROFILE**  
SCALE H 1"=20'  
V 1"=20'

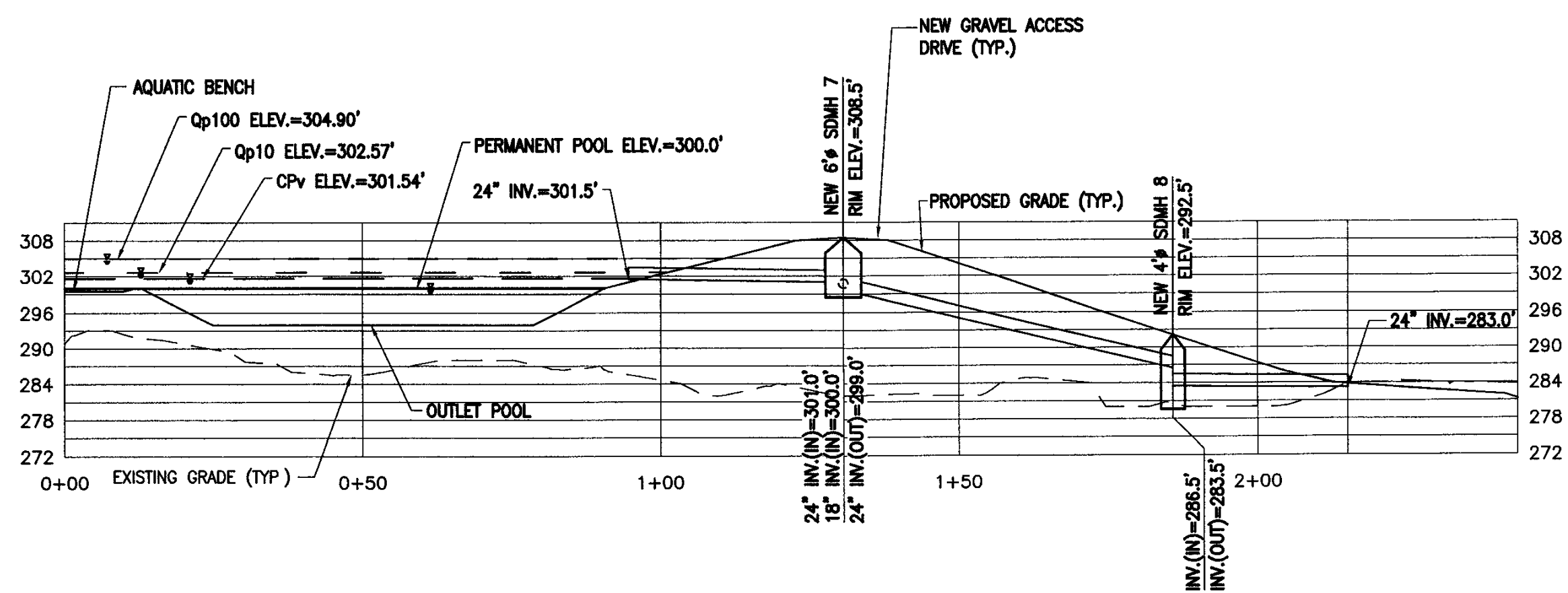

**B PROFILE**  
SCALE H 1"=20'  
V 1"=20'

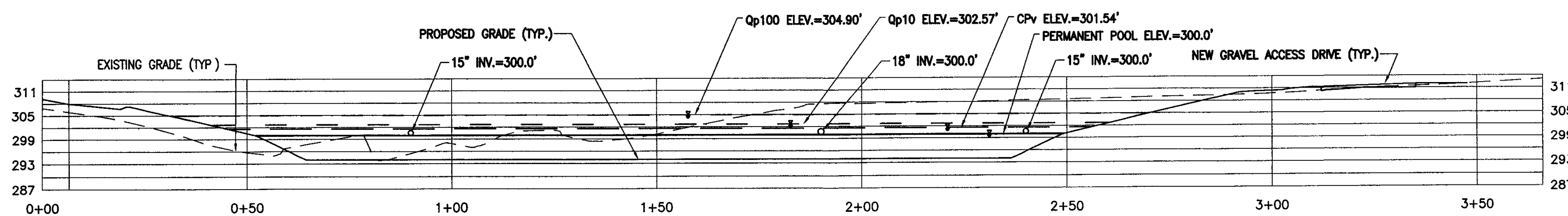

**C PROFILE**  
SCALE H 1"=20'  
V 1"=20'

**EARTHWORK SUMMARY**  
 QUANTITY OF CUT = 11,800 C.Y.  
 QUANTITY OF FILL = 10,700 C.Y.  
 EXCESS MATERIAL = 1,100 C.Y.

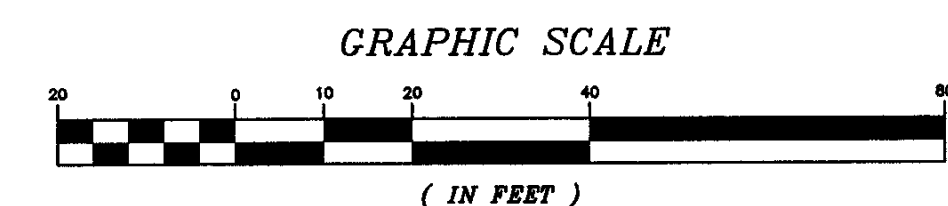

CIVIL &  
ENVIRONMENTAL  
ENGINEERS

**FA & A**  
FORCIER  
ALDRICH &  
ASSOCIATES

6 Market Place, Suite 2  
Essex, Jct., VT 05452  
P 802.879.7733  
F 802.879.1742

TOWN OF COLCHESTER  
COLCHESTER, VERMONT

FORT ETHAN ALLEN  
STORMWATER IMPROVEMENTS

NO.	REVISION DESCRIPTION	JJD	CHECKED
3/08	TOWN AND L&D COMMENTS		

DESIGNED RM	PROJECT NO 07037
DRAWN JEB	DRAWING NO 4
CHECKED JJD	SHEET 6
DATE OCT 2007	

**PROPOSED  
DETENTION POND  
PROFILES**

07037-COLCHESTER.dwg, 3/18/2008 10:43:33 AM



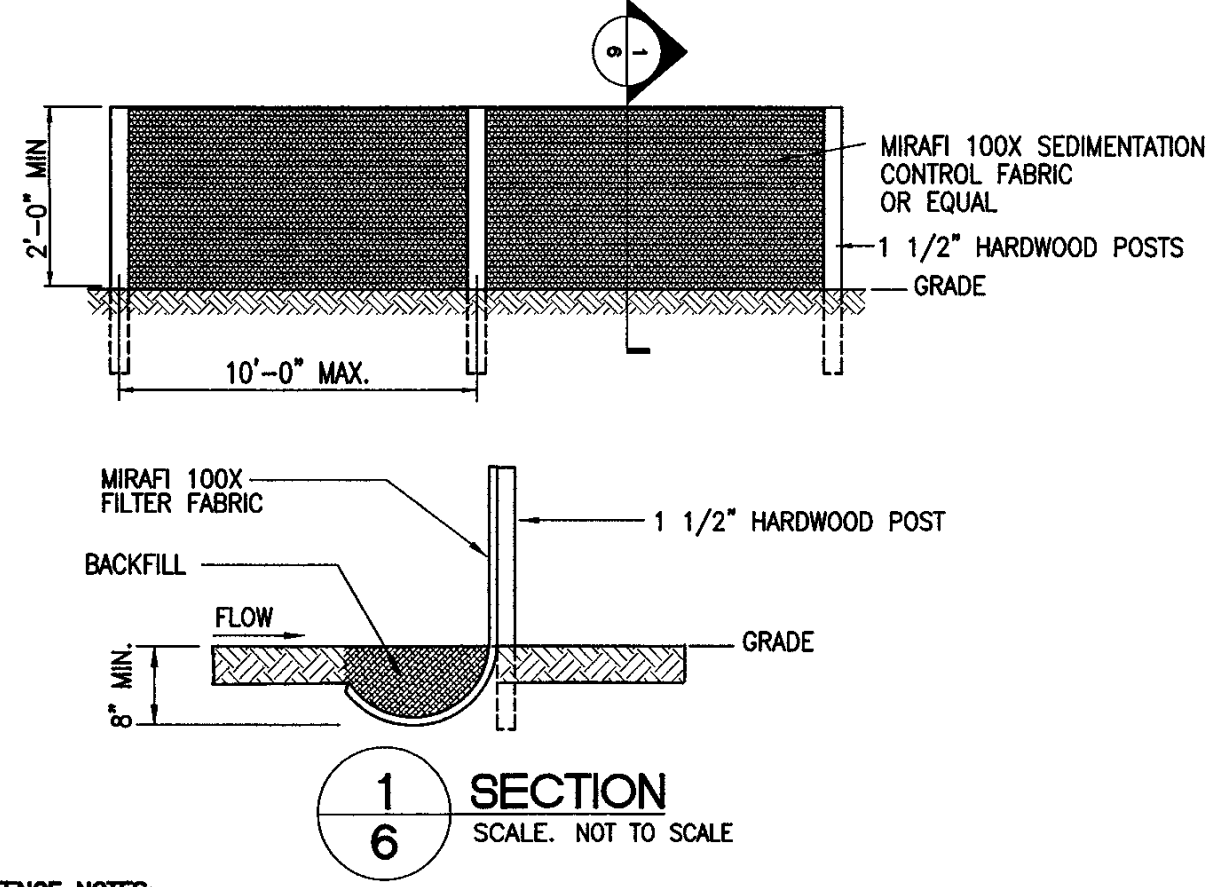

- SILT FENCE NOTES:**
- SILT FENCE SHALL BE PRE-FABRICATED EROSION CONTROL FENCE BY MIRAFI OR APPROVED EQUAL
  - INSTALL WHERE SHOWN ON PLANS. THE FENCE SHALL BE INSTALLED PARALLEL TO CONTOURS WHERE POSSIBLE. THE ENDS OF THE FENCE SHOULD BE CURVED UP HILL TO PREVENT FLOW AROUND THE ENDS
  - SECTIONS OF THE SILT FENCE SHALL BE JOINED TO OVERLAP BY FOLDING FABRIC AROUND EACH POST ONE FULL TURN. DRIVE POSTS TIGHTLY TOGETHER AND SECURE TOPS OF POSTS BY TYING OFF WITH CORD OR WIRE TO PREVENT FLOW-THROUGH OR BUILT-UP SEDIMENT AT JOINT
  - INSPECT ALL SILT FENCE AT LEAST ONCE A WEEK AND WITHIN 24 HOURS AFTER EACH RAINFALL. MAINTENANCE SHALL BE PERFORMED AS NEEDED, AND SEDIMENT REMOVED WHEN SEDIMENT REACHES 1/3 HEIGHT OF SILT FENCE
  - UPON FINAL STABILIZATION OF THE AREA UP HILL OF THE FABRIC, THE FABRIC SHALL BE REMOVED WITH THE APPROVAL OF THE ENGINEER

**A**  
**6** TEMPORARY SILT FENCE DETAIL  
SCALE: NOT TO SCALE

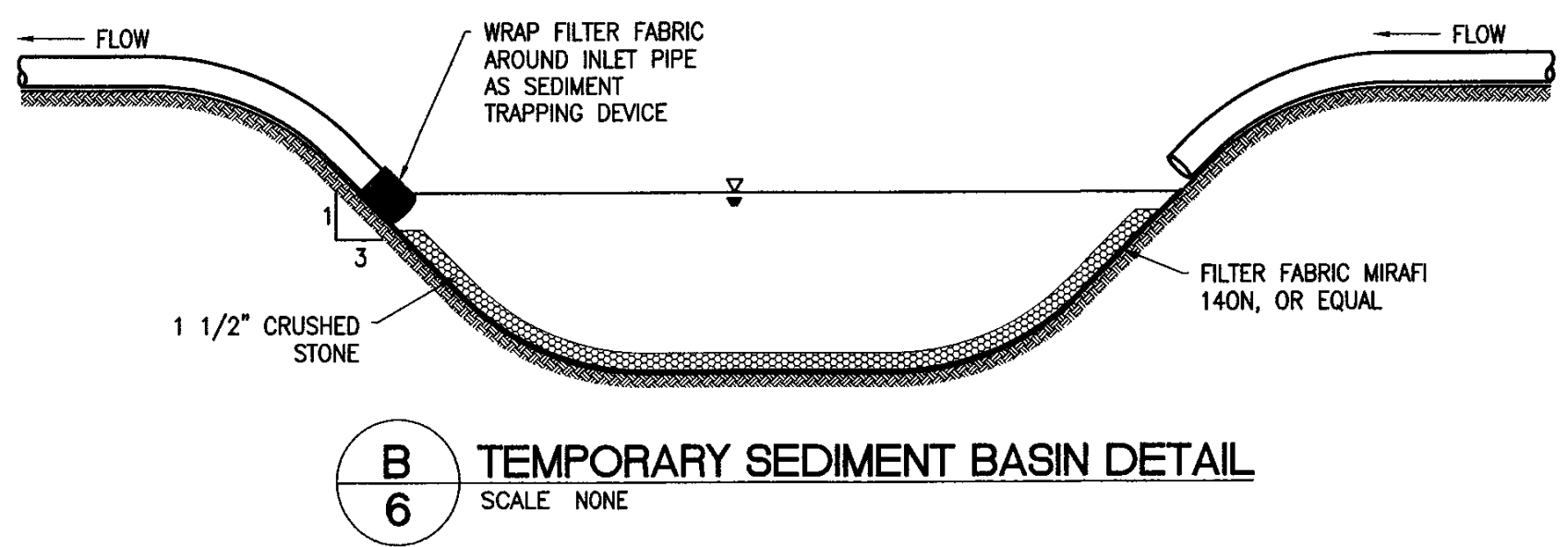

**B**  
**6** TEMPORARY SEDIMENT BASIN DETAIL  
SCALE: NONE

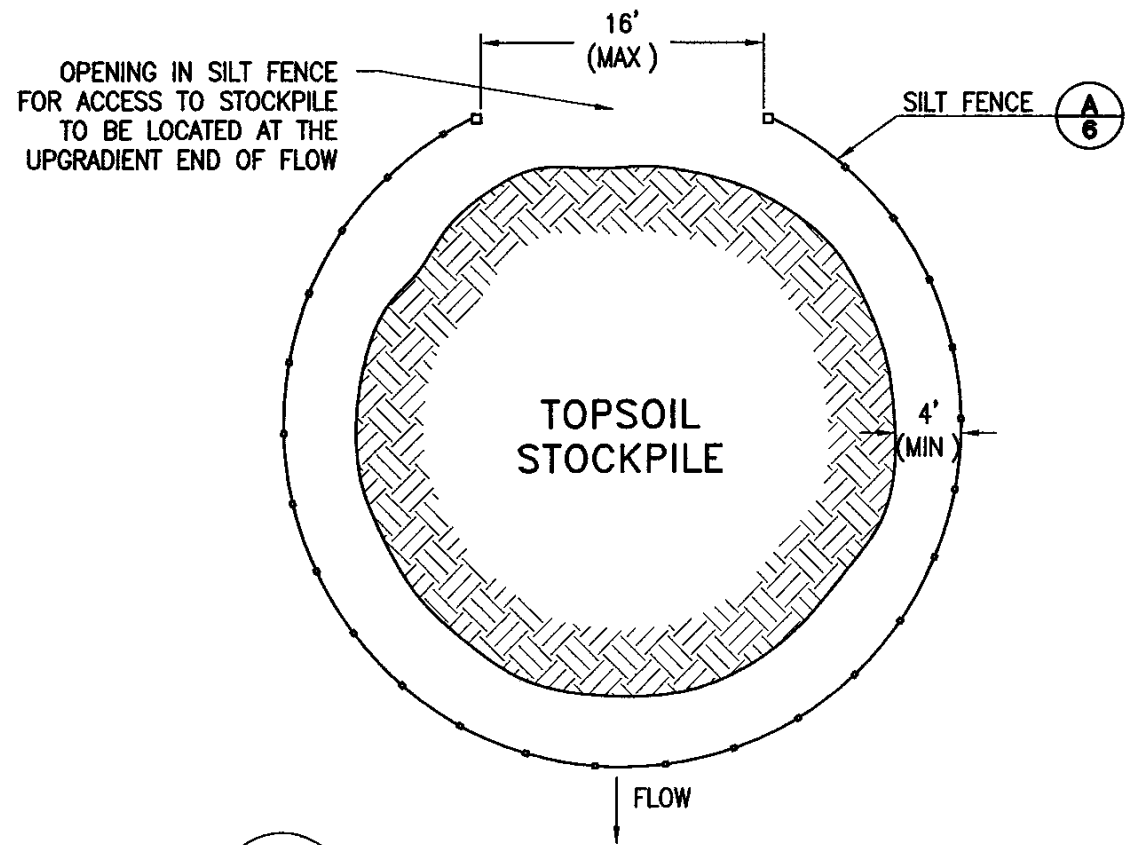

**D**  
**6** TOPSOIL STOCKPILE DETAIL  
SCALE: NONE

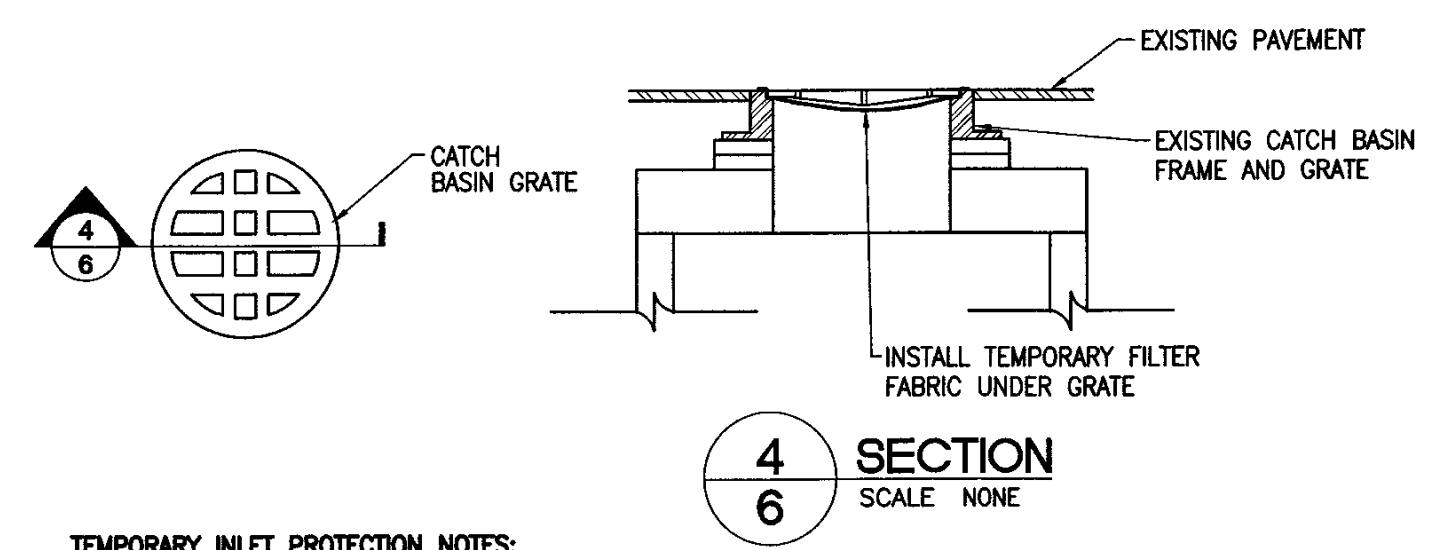

**4**  
**6** SECTION  
SCALE: NONE

- TEMPORARY INLET PROTECTION NOTES:**
- UNDERGRATE FABRIC INLET PROTECTION SHALL ONLY BE USED WHERE SHOWN ON PLANS. IT SHOULD ONLY BE USED FOR EXISTING CATCH BASINS IN EXISTING PAVED AREAS FOR LINEAR PIPELINE PROJECTS WHERE AMOUNT OF SEDIMENT RUN OFF IS MINIMAL AND DURATION OF CONSTRUCTION IS SHORT
  - LIFT THE GRATE AND INSTALL FILTER FABRIC (MIRAFI 140NL OR EQUAL) OVER THE FRAME, AND THEN SET GRATE BACK IN PLACE
  - INSPECT EACH INLET AT LEAST ONCE A WEEK AND WITHIN 24 HOURS AFTER EVERY RAINFALL. REPAIR AND REPLACEMENT OF INLET PROTECTION SHALL BE MADE AT TIME OF INSPECTION
  - UPON STABILIZATION OF THE AREA UPSTREAM FROM THE INLET, THE PROTECTION SHALL BE REMOVED WITH THE APPROVAL OF THE ENGINEER

**E**  
**6** TEMPORARY FABRIC UNDER GRATE INLET PROTECTION DETAIL  
SCALE: NOT TO SCALE

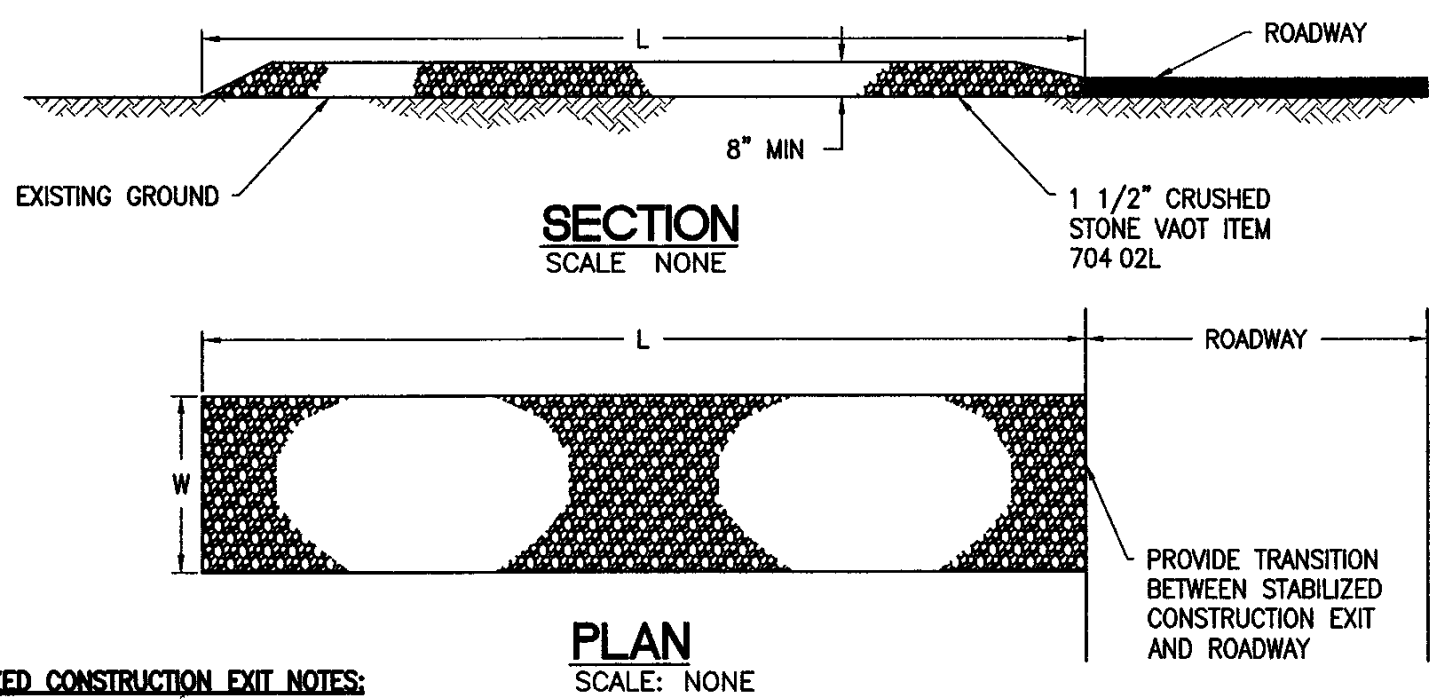

**F**  
**6** STABILIZED CONSTRUCTION EXIT  
SCALE: NONE

- STABILIZED CONSTRUCTION EXIT NOTES:**
- LENGTH (L) SHALL BE 40' MINIMUM WHERE SUFFICIENT SPACE IS AVAILABLE
  - WIDTH (W) SHALL NOT BE LESS FULL WIDTH OF ALL POINTS OF INGRESS AND EGRESS
  - WHEN NECESSARY, WHEELS SHALL BE CLEANED TO REMOVE SEDIMENT PRIOR TO ENTRANCE ONTO ROADWAY WHEN WASHING IS REQUIRED, IT SHALL BE DONE ON AN AREA STABILIZED WITH CRUSHED STONE, WHICH DRAINS INTO APPROVED SEDIMENT TRAP OR SEDIMENT BASIN. ALL SEDIMENT SHALL BE PREVENTED FROM ENTERING ANY STORM DRAIN, DITCH, OR WATERCOURSE THROUGH USE OF METHODS AS APPROVED BY THE ENGINEER
  - THE ENTRANCE SHALL BE MAINTAINED IN A CONDITION WHICH WILL PREVENT TRACKING OR FLOWING OF SEDIMENT ONTO ROADWAY. THIS MAY REQUIRE PERIODIC TOP DRESSING WITH ADDITIONAL STONE AS CONDITIONS DEMAND AND REPAIR AND OR CLEANOUT OF ANY MEASURES USED TO TRAP SEDIMENT. ALL SEDIMENT SPILLED, DROPPED, OR WASHED ONTO PUBLIC ROADWAY MUST BE REMOVED IMMEDIATELY.

**F**  
**6** STABILIZED CONSTRUCTION EXIT  
SCALE: NONE

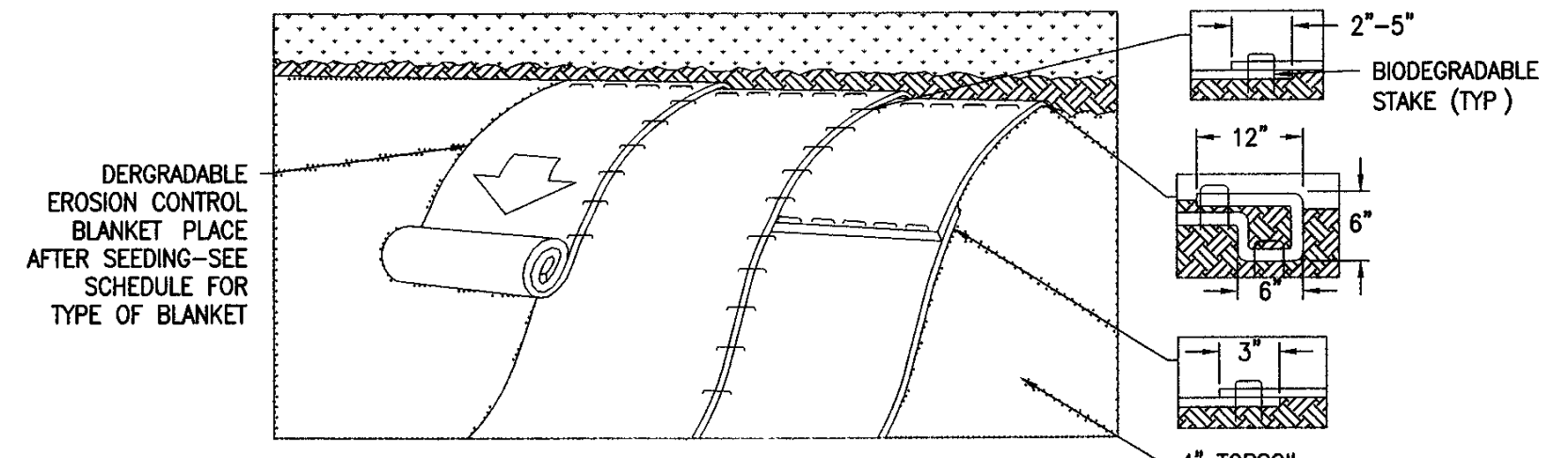

**DEGRADABLE BLANKET SLOPE STABILIZATION NOTES:**

- INSTALL WHERE SHOWN ON PLANS
- CONTRACTOR SHALL USE BIODEGRADABLE STAKES FOR FASTENERS. WIRE STAPLES ARE NOT ACCEPTABLE
- PREPARE SOIL BEFORE INSTALLING BLANKETS, INCLUDING ANY NECESSARY APPLICATION OF LIME, FERTILIZER, AND SEED
- BEGIN AT THE TOP OF THE SLOPE BY ANCHORING THE BLANKET IN A 6" DEEP X 6" WIDE TRENCH WITH APPROXIMATELY 12" OF BLANKET EXTENDED BEYOND THE UP-SLOPE PORTION OF THE TRENCH. ANCHOR THE BLANKET WITH A ROW OF BIODEGRADABLE STAKES APPROXIMATELY 12" APART IN THE BOTTOM OF THE TRENCH. BACKFILL AND COMPACT THE TRENCH AFTER STAKING. APPLY SEED TO COMPACTED SOIL AND FOLD REMAINING 12" PORTION OF BLANKET BACK OVER SEED AND COMPACTED SOIL. SECURE BLANKET OVER COMPACTED SOIL WITH A ROW OF BIODEGRADABLE STAKES SPACED APPROXIMATELY 12" APART ACROSS THE WIDTH OF THE BLANKET
- BLANKETS WILL UNROLL WITH APPROPRIATE SIDE AGAINST THE SOIL SURFACE. ALL BLANKETS MUST BE SECURELY FASTENED TO SOIL SURFACE BY PLACING BIODEGRADABLE STAKES IN APPROPRIATE LOCATIONS AS SHOWN IN THE STAPLE PATTERN GUIDE. WHEN USING OPTIONAL DOT SYSTEM, BIODEGRADABLE STAKES SHOULD BE PLACED THROUGH EACH OF THE COLORED DOTS CORRESPONDING TO THE APPROPRIATE STAPLE PATTERN
- THE EDGES OF PARALLEL BLANKETS MUST BE STAPLED WITH APPROXIMATELY 2"-5" OVERLAP DEPENDING ON BLANKET TYPE. TO ENSURE PROPER SEAM ALIGNMENT, PLACE THE EDGE OF THE OVERLAPPING BLANKET (BLANKET BEING INSTALLED ON TOP) EVEN WITH THE COLORED SEAM STITCH ON THE PREVIOUSLY INSTALLED BLANKET
- CONSECUTIVE BLANKETS SPICED DOWN THE SLOPE MUST BE PLACED END OVER END (SHINGLE STYLE) WITH AN APPROXIMATE 3" OVERLAP. STAPLE THROUGH OVERLAPPED AREA, APPROXIMATELY 12" APART ACROSS ENTIRE BLANKET WIDTH
- IN LOOSE SOIL CONDITIONS, THE USE OF STAKE LENGTHS GREATER THAN 6" MAY BE NECESSARY TO PROPERLY SECURE THE BLANKETS

**DEGRADABLE EROSION CONTROL BLANKET SCHEDULE**

TYPE	SLOPE (X)	BLANKET DESCRIPTION	MODEL NO
A	4:1-3:1	SINGLE NET STRAW BLANKET	NORTH AMERICAN GREEN S75 OR EQUAL
B	3:1-2:1	DOUBLE NET STRAW BLANKET	NORTH AMERICAN GREEN S150 OR EQUAL
C	2:1-1:1	DOUBLE NET BLANKET 70% STRAW/30% COCONUT	NORTH AMERICAN GREEN SC150 OR EQUAL
D	1:1 OR GREATER	DOUBLE NET COCONUT BLANKET	NORTH AMERICAN GREEN SC125 OR EQUAL

**C**  
**6** DEGRADABLE EROSION CONTROL BLANKET SLOPE STABILIZATION DETAIL  
SCALE: NONE

**EROSION CONTROL NOTES:**

- EROSION CONTROL MEASURES ARE TO BE IMPLEMENTED PRIOR TO PERFORMING ANY EARTHWORK DOWNSTREAM OF THE DISTURBED AREA AND AS DIRECTED BY THE CONSTRUCTION ENGINEER. THE MEASURES SHALL BE MAINTAINED UNTIL THE UPSTREAM DISTURBED AREA HAS BEEN PERMANENTLY STABILIZED AND AS DIRECTED BY THE CONSTRUCTION ENGINEER. THE CONTRACTOR SHALL INSTALL ALL TEMPORARY EROSION PREVENTION AND SEDIMENT CONTROL MEASURES AS SHOWN ON THE CONTRACT DRAWINGS. THE CONTRACTOR SHALL PROVIDE ANY ADDITIONAL MEASURES DETERMINED NECESSARY IN THE FIELD
- SILT FENCE SHALL BE INSTALLED, AS SHOWN ON THE CONTRACT DRAWINGS PRIOR TO ANY EARTHWORK DOWNSTREAM OF THE DISTURBED AREA AND AS DIRECTED BY THE CONSTRUCTION ENGINEER. THE SILT FENCE SHALL BE MAINTAINED AND CLEANED UNTIL THE UPSTREAM DISTURBED AREA HAS BEEN PERMANENTLY STABILIZED AND AS DIRECTED BY THE CONSTRUCTION ENGINEER. WHERE POSSIBLE NATURAL DRAINAGE WAYS SHALL BE UTILIZED AND LEFT OPEN TO REMOVE EXCESS SURFACE WATER
- STONE CHECK DAMS SHALL BE INSTALLED IN DRAINAGE SWALES, AS SHOWN ON THE CONTRACT DRAWINGS AND AS DIRECTED BY THE CONSTRUCTION ENGINEER. CHECK DAMS SHALL BE INSTALLED IMMEDIATELY FOLLOWING DISTURBANCE OF THE DRAINAGE SWALE AND SHALL BE MAINTAINED UNTIL THE UPSTREAM DISTURBED AREA IS PERMANENTLY STABILIZED AND AS DIRECTED BY THE CONSTRUCTION ENGINEER
- DEGRADABLE EROSION CONTROL BLANKETS SHALL BE INSTALLED ON DISTURBED VEGETATED SLOPES THAT HAVE SLOPES GREATER THAN 4:1. THE CONTRACTOR SHALL INSTALL THE DEGRADABLE EROSION CONTROL BLANKETS PER MANUFACTURER'S RECOMMENDATIONS
- PROPER EROSION CONTROLS SHALL BE PROVIDED AROUND STOCKPILED EXCAVATED MATERIALS. THESE CONTROLS MAY INCLUDE, BUT NOT BE LIMITED TO, THE FOLLOWING METHODS OF EROSION PREVENTION AND SEDIMENT CONTROL: PERIMETER SILT FENCE, INTERCEPTOR DRAINAGE DITCHES, VELOCITY REDUCTION DAMS IN DRAINAGE DITCHES, TEMPORARY BANK PROTECTION SUCH AS RIPRAP, MATTING, OR ARTIFICIAL COVERING, STONE CHECK DAM CONTROL SYSTEMS, SPECIAL STOCKPILING METHODS, AND WATER BARS
- THE CONTRACTOR SHALL PROVIDE A MECHANICAL SWEEPER AND SHALL SWEEP CLEAN THE ROADS IN THE CONSTRUCTION AREAS AS REQUIRED TO REMOVE ACCUMULATED SEDIMENT AND PREVENT SEDIMENT RUNOFF INTO RECEIVING WATERS AND AS DIRECTED BY THE CONSTRUCTION ENGINEER
- TEMPORARY EROSION CONTROL MEASURES SHALL BE UTILIZED BY THE CONTRACTOR AS REQUIRED TO PREVENT ANY SEDIMENTATION FROM RUNNING INTO RECEIVING WATERS. THE CONTRACTOR SHALL MAKE EVERY EFFORT TO MINIMIZE ANY IMPACT OF THE ON-SITE SURFACE RUNOFF ON THE QUALITY OF THE RECEIVING WATERS
- THE SMALLEST PRACTICAL AREA OF LAND SHALL BE DISTURBED AT ANY ONE TIME DURING CONSTRUCTION. WHEN LAND IS DISTURBED DURING CONSTRUCTION, THE DISTURBANCE SHALL BE KEPT TO THE SHORTEST PRACTICAL DURATION AS APPROVED BY THE CONSTRUCTION ENGINEER. LAND SHALL NOT BE LEFT DISTURBED DURING THE WINTER MONTHS AND OVERWINTER STABILIZATION MEASURES SHALL BE INSTALLED PRIOR TO OCTOBER 15TH
- ALL DISTURBED AREAS AND SIDE SLOPES WHICH ARE FINISH GRADED WITH NO FURTHER CONSTRUCTION TO TAKE PLACE SHALL BE TOPSOILED, LIMED, FERTILIZED, SEEDED, AND MULCHED WITHIN 48 HOURS OF FINAL GRADING. A MINIMUM OF 4 INCHES OF TOPSOIL SHALL BE PLACED. THE FOLLOWING APPLICATION RATES SHALL APPLY: 2,000 LBS/ACRE OF LIME, 300 LBS/ACRE OF 10-20-20 FERTILIZER AND 40 LBS/ACRE OF SEED.
- NO DISTURBED AREAS SHALL BE LEFT UNSEEDING AND UNMULCHED FOR MORE THAN SEVEN (7) DAYS. DISTURBED AREAS WHICH WILL BE REGRADED LATER DURING CONSTRUCTION SHALL BE MULCHED AND SEEDED WITH RYE GRASS TO PREVENT EROSION. HAY OR STRAW MULCH SHALL BE APPLIED TO ALL FRESHLY SEEDED AREAS AT THE RATE OF 2 TONS PER ACRE. BALES SHALL BE UNSPOILED, AIR DRIED, AND FREE FROM WEED, SEEDS, AND ANY COARSE MATERIAL. CONTRACTOR MAY ALSO USE EROSION MATTING OR OTHER APPROVED METHODS OF TEMPORARY COVER
- ALL EROSION PREVENTION AND SEDIMENT CONTROL STRUCTURES AND MEASURES SHALL BE INSPECTED BY OR UNDER THE DIRECTION OF THE ON-SITE COORDINATOR AT LEAST EVERY SEVEN (7) CALENDAR DAYS AND AS SOON AS POSSIBLE BUT NO LATER THAN 24 HOURS AFTER ANY STORM EVENT WHICH GENERATES A DISCHARGE OF STORMWATER RUNOFF FROM THE CONSTRUCTION SITE
- AFTER ALL UPSTREAM DISTURBED AREAS HAVE BEEN PERMANENTLY STABILIZED AND AS DIRECTED BY THE CONSTRUCTION ENGINEER, THE DOWNSTREAM TEMPORARY EROSION CONTROL MEASURES ARE TO BE REMOVED AND THE ACCUMULATED SEDIMENT PROPERLY DISPOSED OF. THE AREA DISTURBED BY THE REMOVAL OF TEMPORARY MEASURES SHALL BE PREPARED, SEEDED, AND MULCHED

CIVIL & ENVIRONMENTAL ENGINEERS  
6 Market Place, Suite 2  
Essex Jct., VT 05452  
P 802.879.7733  
F 802.879.1742

**FA&A**  
FORCIER  
ALDRICH &  
ASSOCIATES

TOWN OF COLCHESTER  
COLCHESTER, VERMONT

FORT ETHAN ALLEN  
STORMWATER IMPROVEMENTS

NO	DATE	REVISION DESCRIPTION	CHECKED
1	3/08	TOWN AND L&D COMMENTS	JJD
2			
3			
4			
5			
6			
7			
8			
9			
10			
11			
12			

DESIGNED: RM  
DRAWN: JEB  
CHECKED: JJD  
DATE: OCT 2007

PROJECT NO: 07037  
DRAWING NO: 6  
SHEET 8

07037-COLCHESTER.dwg 3/18/2008 10:51:11 AM