

MAIN FLOOR PLAN - MECHANICAL
SCALE: 1/4" = 1'-0"

GENERAL NOTES:

- 1) ALL RISERS AND RISINGS TO RADIATION CABINET HEATERS AND UNIT HEATERS TO BE 3/4"
- 2) ALL SUPPLY AND RETURN VANS TO BE AT CEILING. KEEP HIGH AS POSSIBLE. PROVIDE 1" CLEARANCE OF SPACES WHERE POSSIBLE. COORDINATE ROUTING WITH EXISTING CONDITIONS.
- 3) ZONE VALVES SHALL BE FULL LINE SIZE.
- 4) REFER TO DWGS. A1 AND E1 FOR SELECTED EQUIPMENT REQUIRED. COORDINATE ALL MECHANICAL WORK AS REQUIRED.
- 5) AS TRANSFER SADDLES IN WALL. SEE DWG. A1 FOR LOCATION. 2" RIGID. PROVIDE WALL SLEEVE WITH UL LABELED FIRE DRYER AND 1/2"x1/2" GALVANIZED METAL SCREENING OVER ALL OPENINGS.

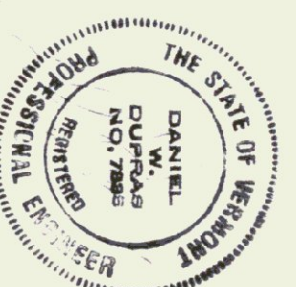
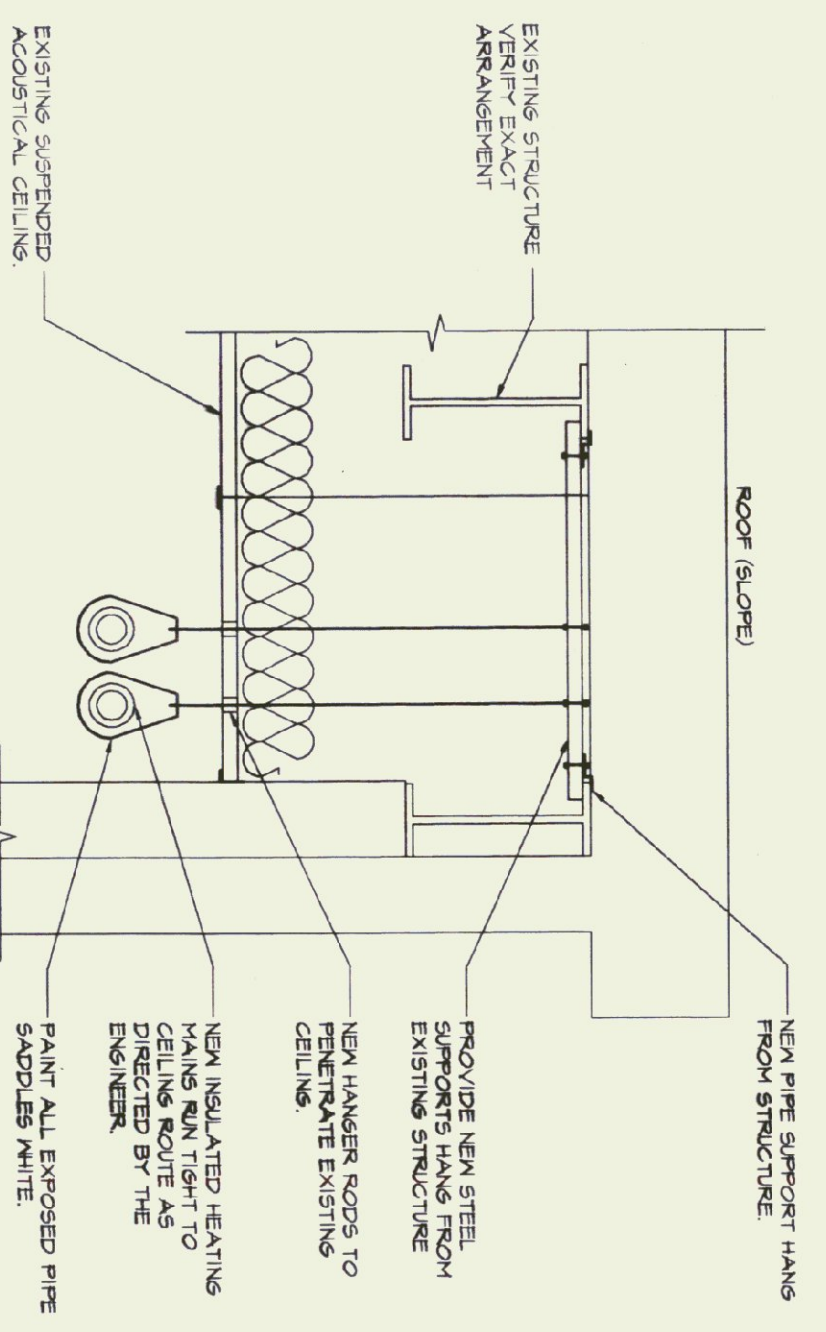

NO.	ISSUED FOR	DATE
1	OWNER REVIEW	10/18/94
2	OWNER REVIEW	01/25/00
3	BIDDING	05/10/00
4	RE-BID INCORPORATE ADDENDA	11/00



CHARLES F. LANE, P.E.
DANIEL W. DIRRAS, P.E.
WILLIAM C. LANE, P.E.
51 HILLINGTON AVENUE
RUTLAND, VERMONT 05701
TELEPHONE: (802) 747-3346
FAX/MODERN: (802) 747-3356

MECHANICAL PLANS AND LEGEND

A.O.T. DISTRICT NO. 4 OFFICE HEATING SYSTEM REPLACEMENT WHITE RIVER JUNCTION, VERMONT

	MOTOR OPERATED DAMPER		THERMOSTAT
	DAMPER FOR FINE DAMPER		FUEL OIL SUPPLY
	PIPE ANCHOR		GATE VALVE
	PIPE GUIDE		BALL VALVE
	BALANCING VALVE		CHECK VALVE
	2-WAY CONTROL VALVE		PRESSURE GAUGE
	PRESSURE REDUCING VALVE		PRESSURE RELIEF VALVE
	BACKFLOW PREVENTER		DRAIN VALVE
	HOT WATER SUPPLY		THERMOSTAT
	HOT WATER RETURN		PIPE STRAINER WITH BLOWDOWN VALVE
	DOMESTIC COLD WATER		CABINET HEATER
	CHANGE IN PIPE SIZE		UNIT HEATER
	AIR VENT		RADIANT VALVE
			OIL SAFETY VALVE
			LOW VOLTAGE CONTROL WIRING
			120VAC CONTROL WIRING BY E.C.

MECHANICAL LEGEND & ABBREVIATIONS



ENLARGED PLAN - BOILER ROOM
SCALE: 1/2" = 1'-0"

