

1 CORNER DETAIL
1/2" = 1'-0"

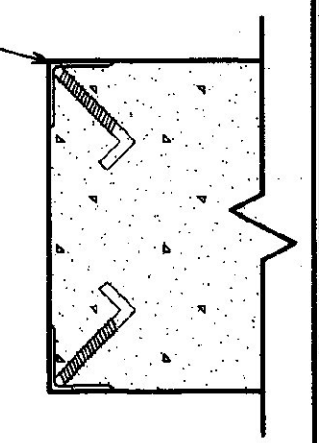

2 CORNER GUARD DETAIL
1/2" = 1'-0"

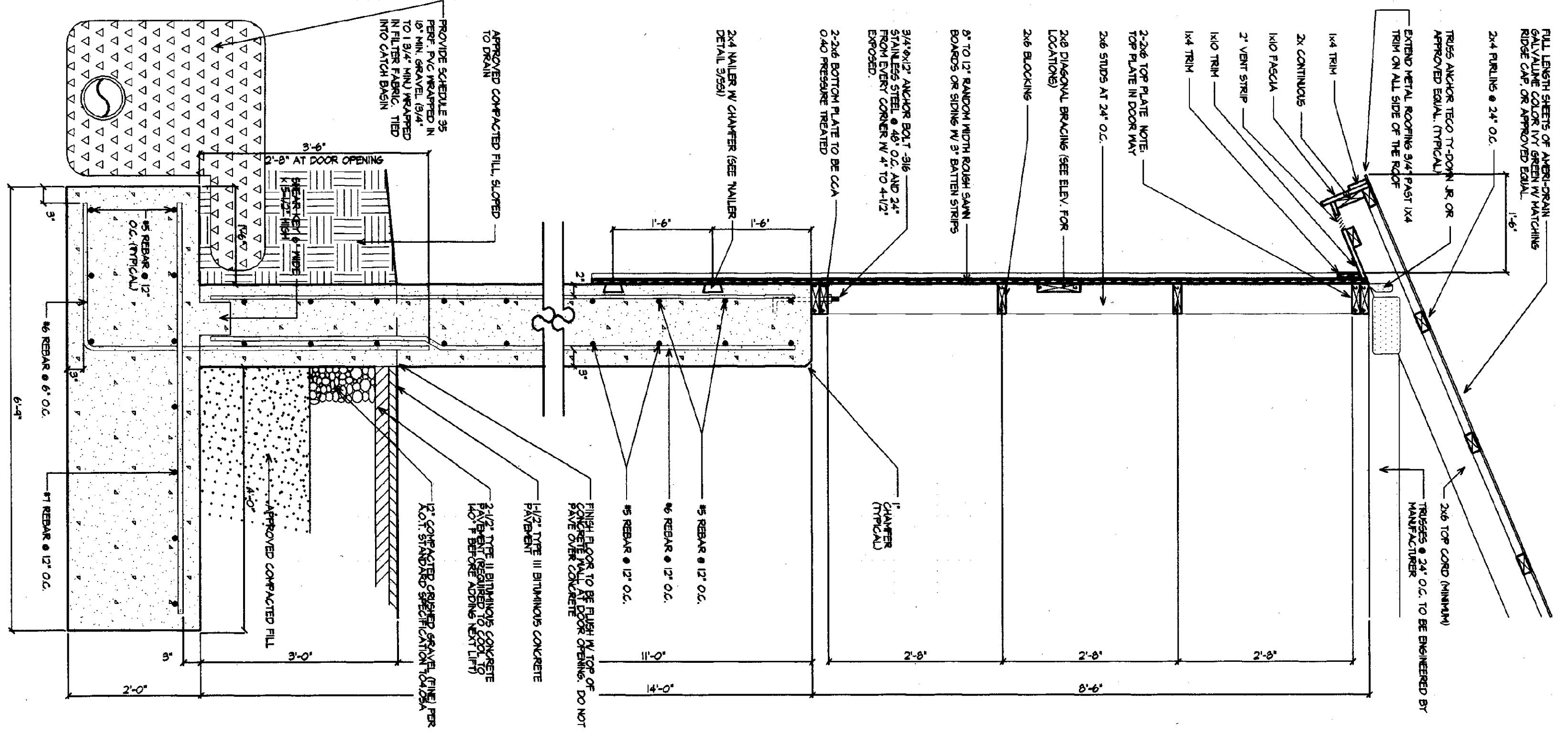

1 WALL SECTION (TYP.)
3/4" = 1'-0"

GENERAL NOTES:
ALL MATERIALS TO BE PROVIDED BY THE CONTRACTOR.
ALL WORK TO BE DONE IN ACCORDANCE WITH THE LATEST EDITIONS OF THE BUILDING CODES AND ALL APPLICABLE LOCAL, STATE AND FEDERAL REGULATIONS.
ALL DIMENSIONS UNLESS OTHERWISE NOTED TO BE IN FEET AND INCHES.
ALL DIMENSIONS TO FACE UNLESS OTHERWISE NOTED.
ALL DIMENSIONS TO FACE UNLESS OTHERWISE NOTED.
ALL DIMENSIONS TO FACE UNLESS OTHERWISE NOTED.
ALL DIMENSIONS TO FACE UNLESS OTHERWISE NOTED.

FINISH NOTES:
ALL FINISHES TO BE PROVIDED BY THE CONTRACTOR.
ALL FINISHES TO BE PROVIDED BY THE CONTRACTOR.
ALL FINISHES TO BE PROVIDED BY THE CONTRACTOR.
ALL FINISHES TO BE PROVIDED BY THE CONTRACTOR.
ALL FINISHES TO BE PROVIDED BY THE CONTRACTOR.

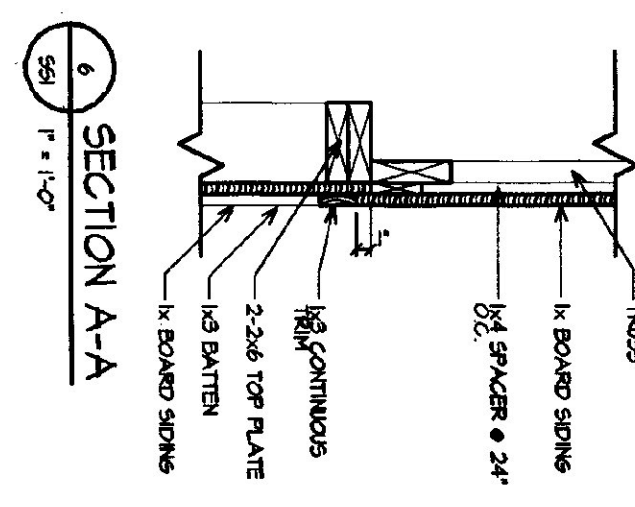

3 SECTION A-A
1" = 1'-0"

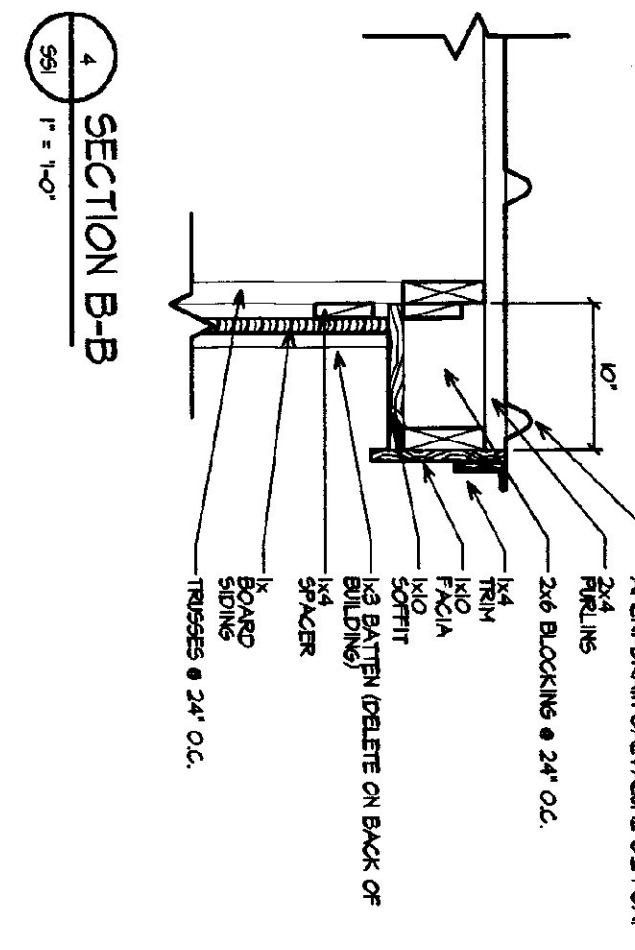

4 SECTION B-B
1" = 1'-0"

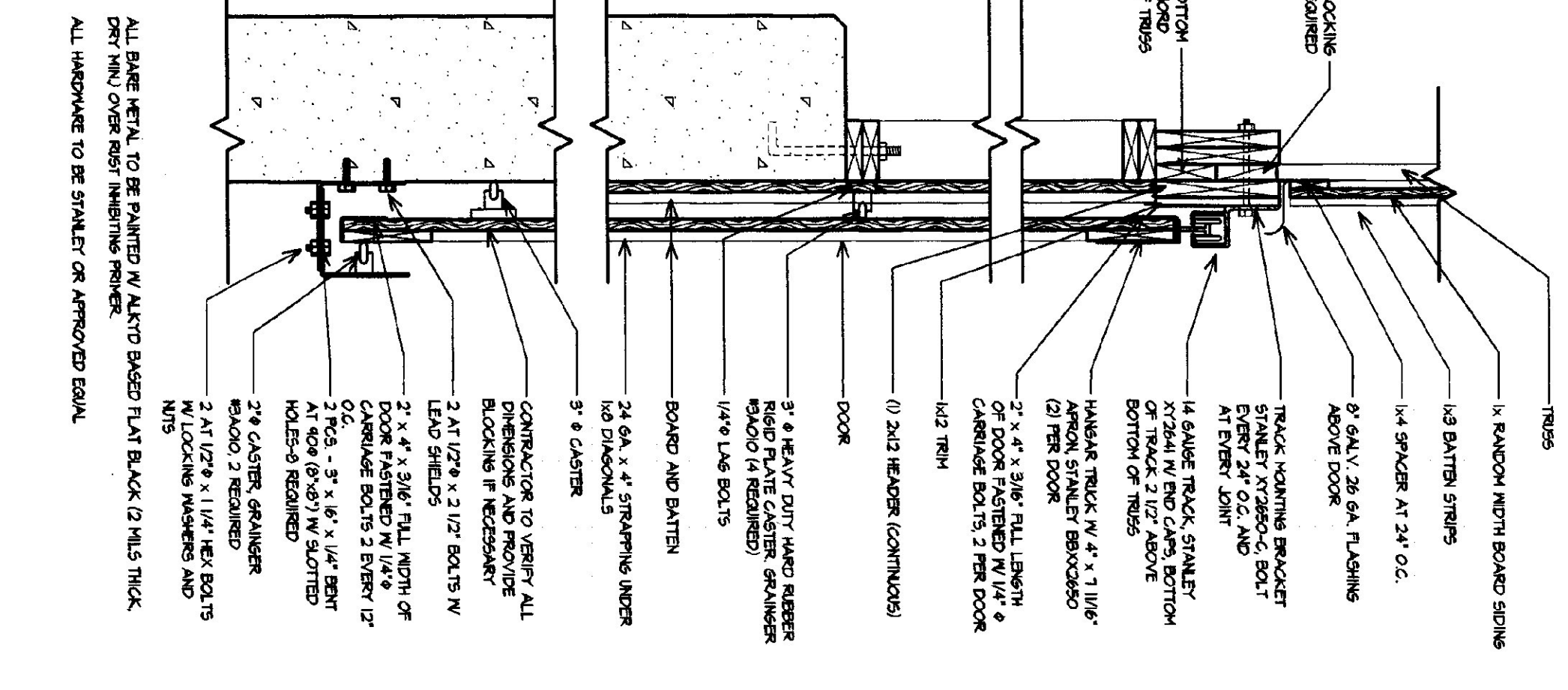

3 DOOR TRACK AND GUIDE
1" = 1'-0"

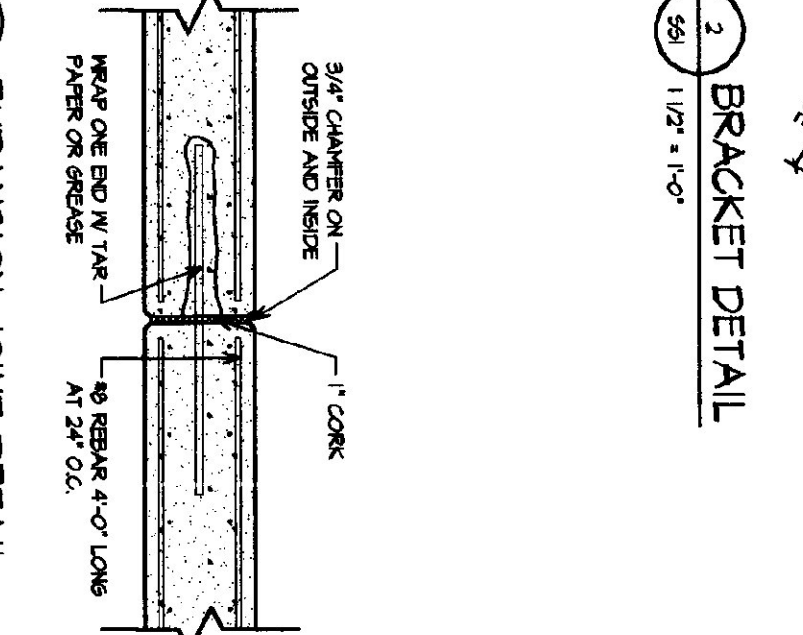

2 BRACKET DETAIL
1/2" = 1'-0"

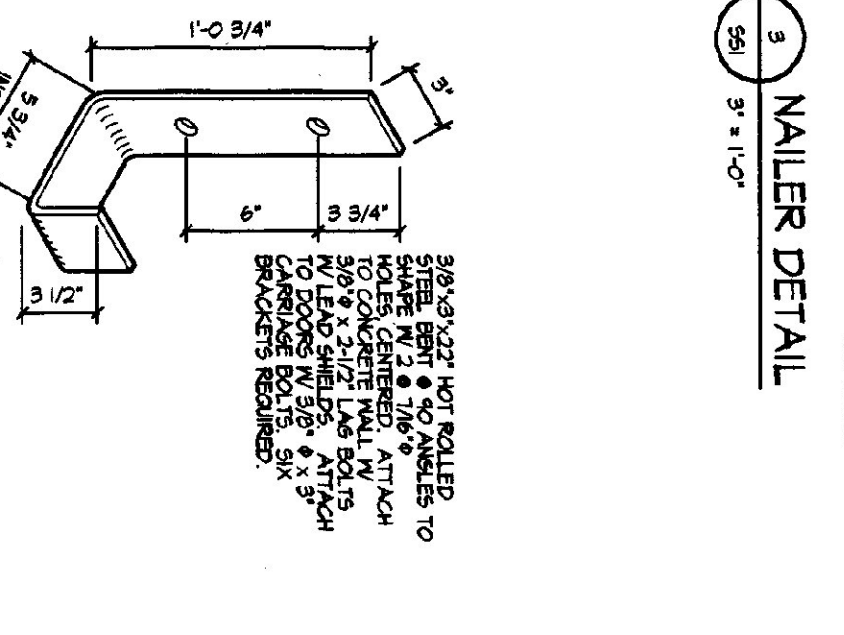

3 MALER DETAIL
3/4" = 1'-0"

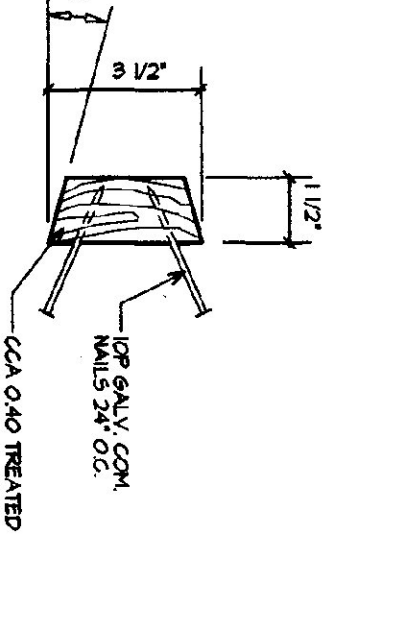

5 EXPANSION JOINT DETAIL
1/2" = 1'-0"

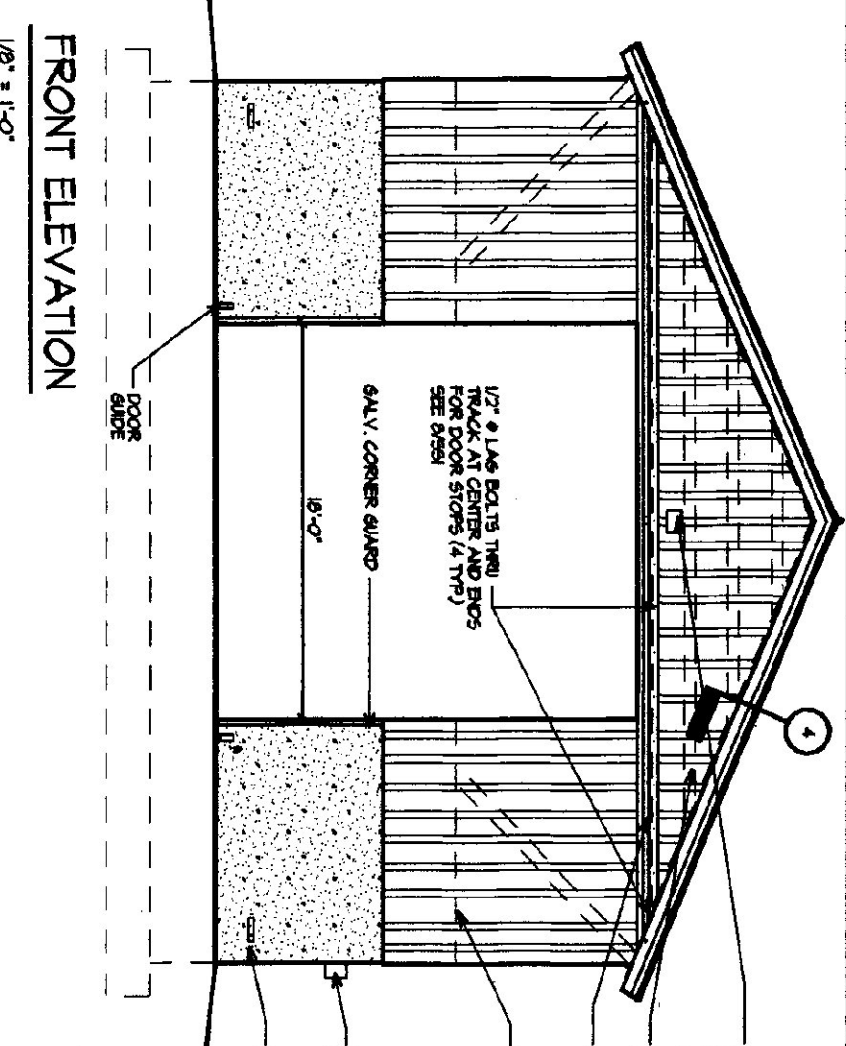

FRONT ELEVATION
1/8" = 1'-0"

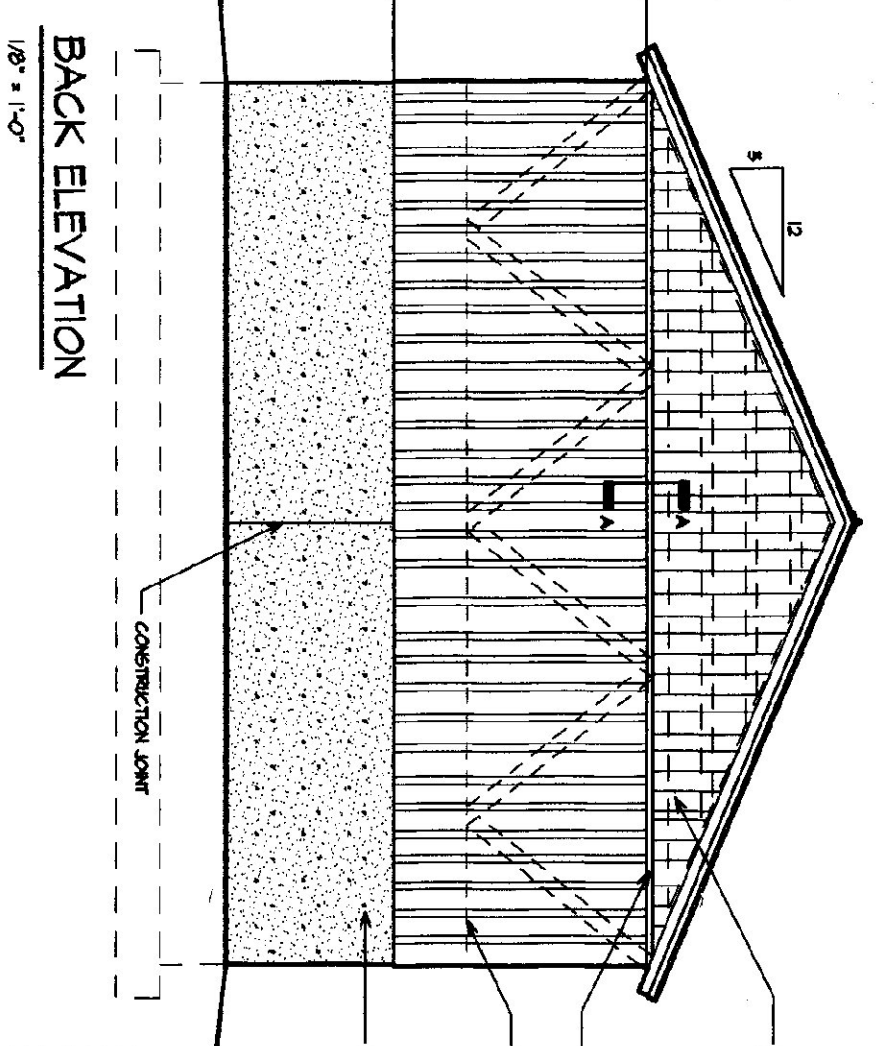

BACK ELEVATION
1/8" = 1'-0"

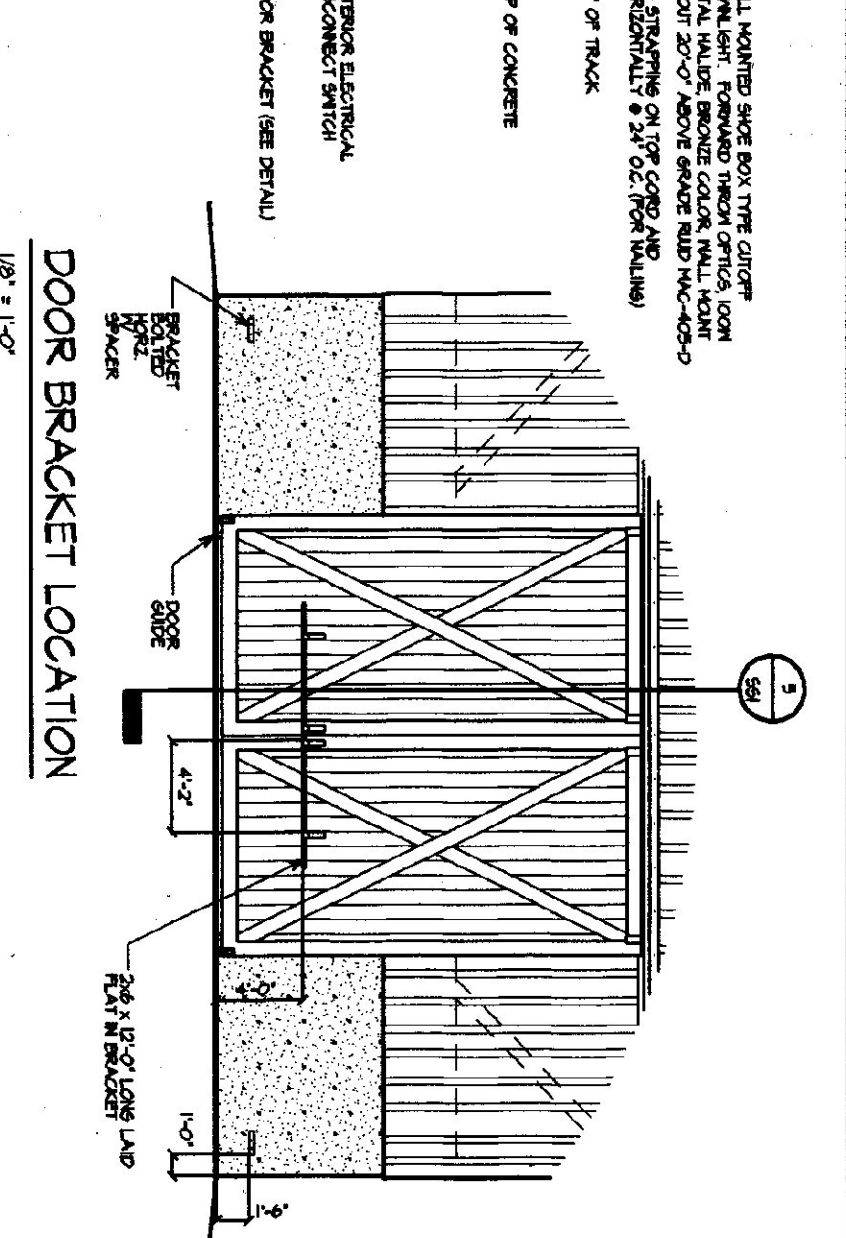

DOOR BRACKET LOCATION
1/8" = 1'-0"

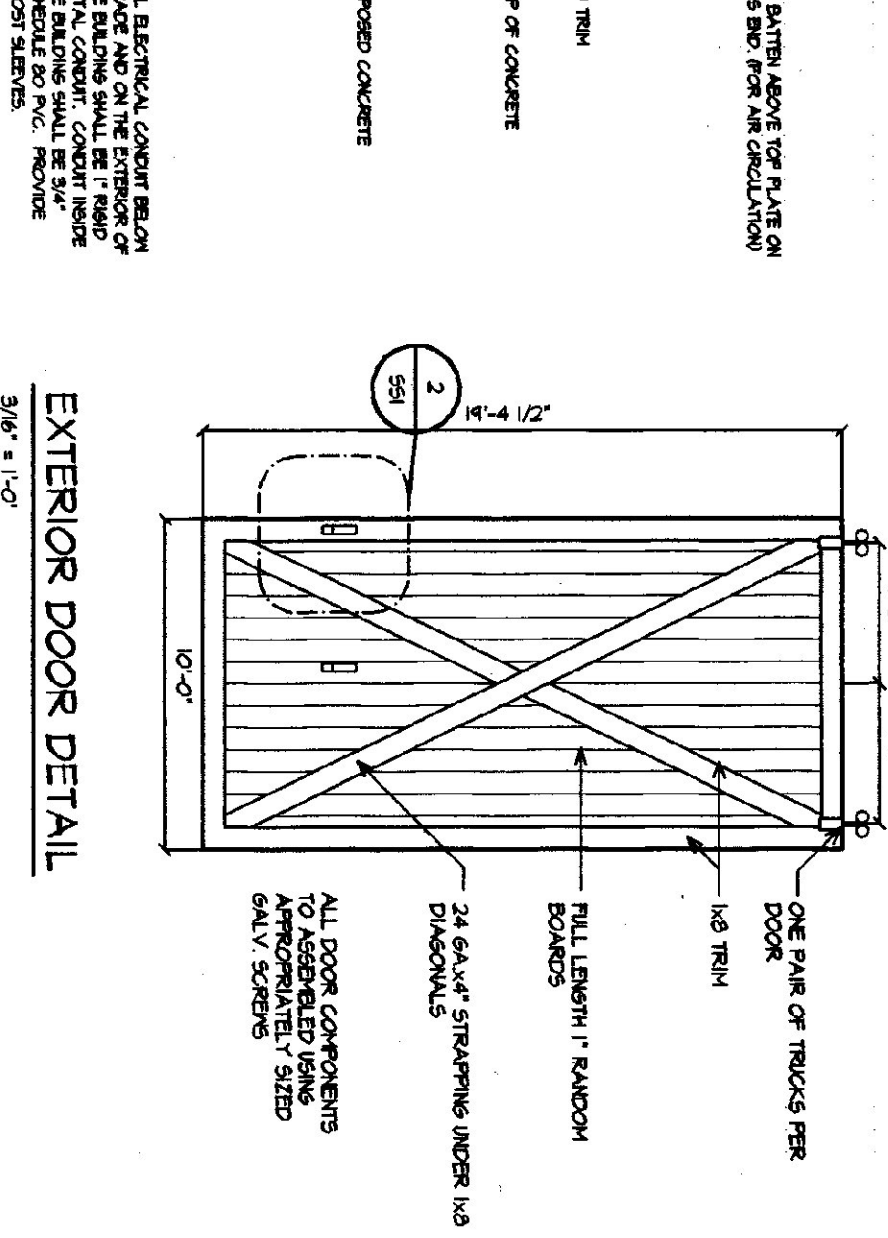

EXTERIOR DOOR DETAIL
3/8" = 1'-0"

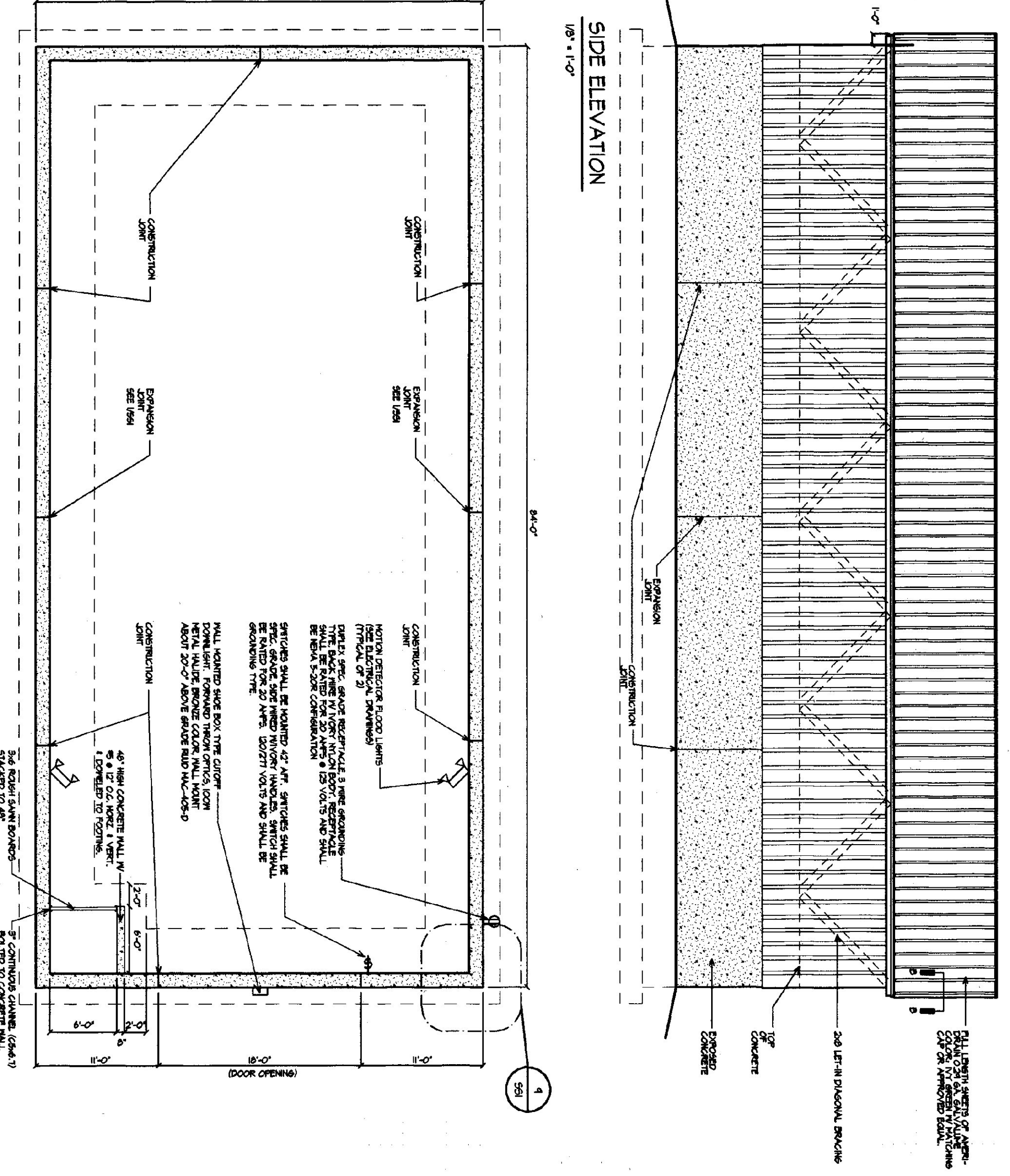

FOUNDATION PLAN
1/8" = 1'-0"