

State of Vermont
 Department of Buildings & General Services
READSBORO A.O.T GARAGE
 PROPOSED MAINTENANCE FACILITY
 READSBORO, VERMONT

INDEX OF SHEETS

C1	SITE PLAN
C2	LAYOUT PLAN
C3	ROAD PROFILE
C4	ROAD CROSS SECTION
C5	ROAD CROSS SECTIONS
C6	ROAD CROSS SECTIONS
C7	ROAD CROSS SECTIONS
C8	SITE DETAILS
C9	SITE DETAILS
C10	SEPTIC SYSTEM DETAILS
C11	SEPTIC SYSTEM DETAILS
A1.1	GENERAL INFO & SITE PLAN
A2.1	ELEVATIONS: FRONT & RIGHT
A2.2	ELEVATIONS: BACK & LEFT
A3.1	FIRST FLOOR PLAN
A3.2	FLOOR PLAN
A4.1	SECTIONS & DETAILS
A4.2	INTERIOR ELEVATIONS
A4.3	INTERIOR ELEVATIONS & WALL SECTIONS
A4.4	WALL SECTIONS
A4.5	WALL SECTIONS & DETAILS
A4.6	WALL SECTIONS & DETAILS
A4.7	WALL SECTIONS & DETAILS
S0.1	WINDOW & STAIR DETAILS
S1.1	STRUCTURAL NOTES & DETAILS
S1.2	FOUNDATION PLAN
S2.1	ROOF FRAMING PLAN
S2.2	STRUCTURAL SECTIONS & DETAILS
S3.1	STRUCTURAL SECTIONS & DETAILS
S3.1	STANDARD STRUCTURAL DETAILS
ES1	ELECTRICAL SITE PLAN
E1	FIRST FLOOR PLAN
M-1	RADIANT HEAT PLAN
M-2	RADIANT HEAT DETAILS & SCHEDULES
SB-1	24' X 48' STORAGE BUILDING
SS-1	40' X 84' SALT/SAND SHED
P-1	PIPING PLANS, DETAILS, & SCHEDULES
V-1	VENTILATION PLANS & DETAILS

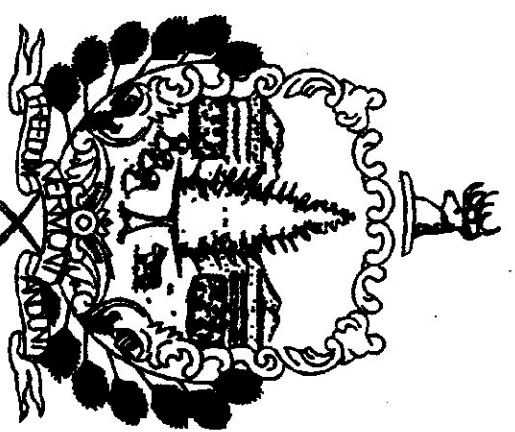

Howard Dean, M.D.
 Governor

FEBRUARY, 2002

LINESYNC ARCHITECTURE
 14 CASTLE HILL
 WILMINGTON, VERMONT 05363
 PHONE#: (802)464-2526
 FAX#: (802)464-2428

AGENCY OF ADMINISTRATION
 DEPT. OF BUILDINGS & GENERAL SERVICES
 2 GOVERNOR AIKEN AVENUE
 MONTPELIER, VERMONT 05633-5801
 THOMAS W. TORTI, COMMISSIONER

AGENCY OF ADMINISTRATION
 DIVISION OF MAINTENANCE & AIR
 NATIONAL LIFE BUILDING
 MONTPELIER, VERMONT 05633-5001
 BRIAN SEARLES, SECRETARY

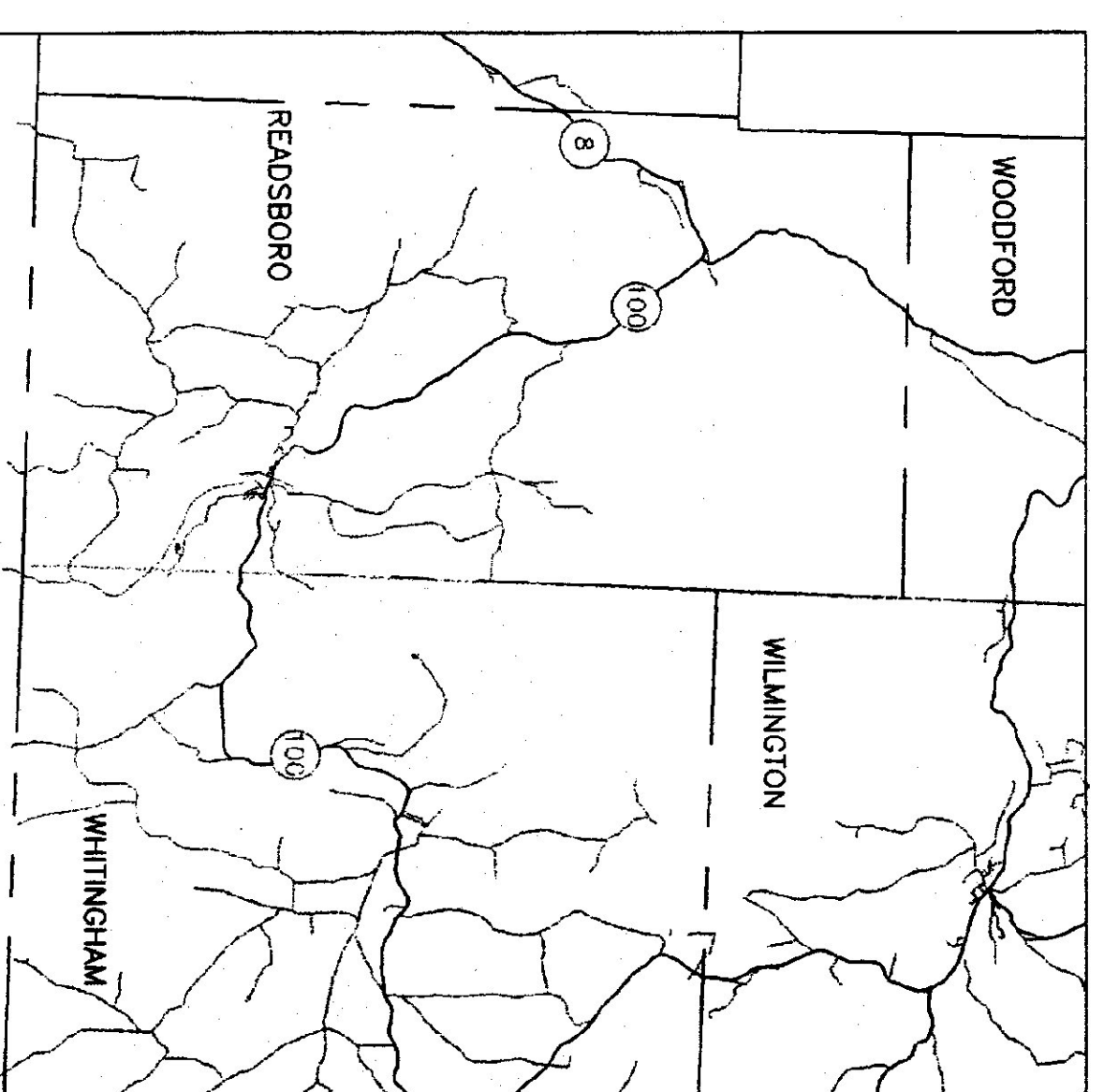

PROJECT LOCATION MAP

LEGEND

- EXISTING CONTOUR
- - - PROPOSED CONTOUR
- HAYBALE DIKE
- UTILITY POLE
- PIPE END SECTION WITH STONE APRON
- SPOT ELEVATION
- PROPOSED TREE LINE
- OHW
- WATER SERVICE LINE
- TEST PIT
- GUIDE WIRE

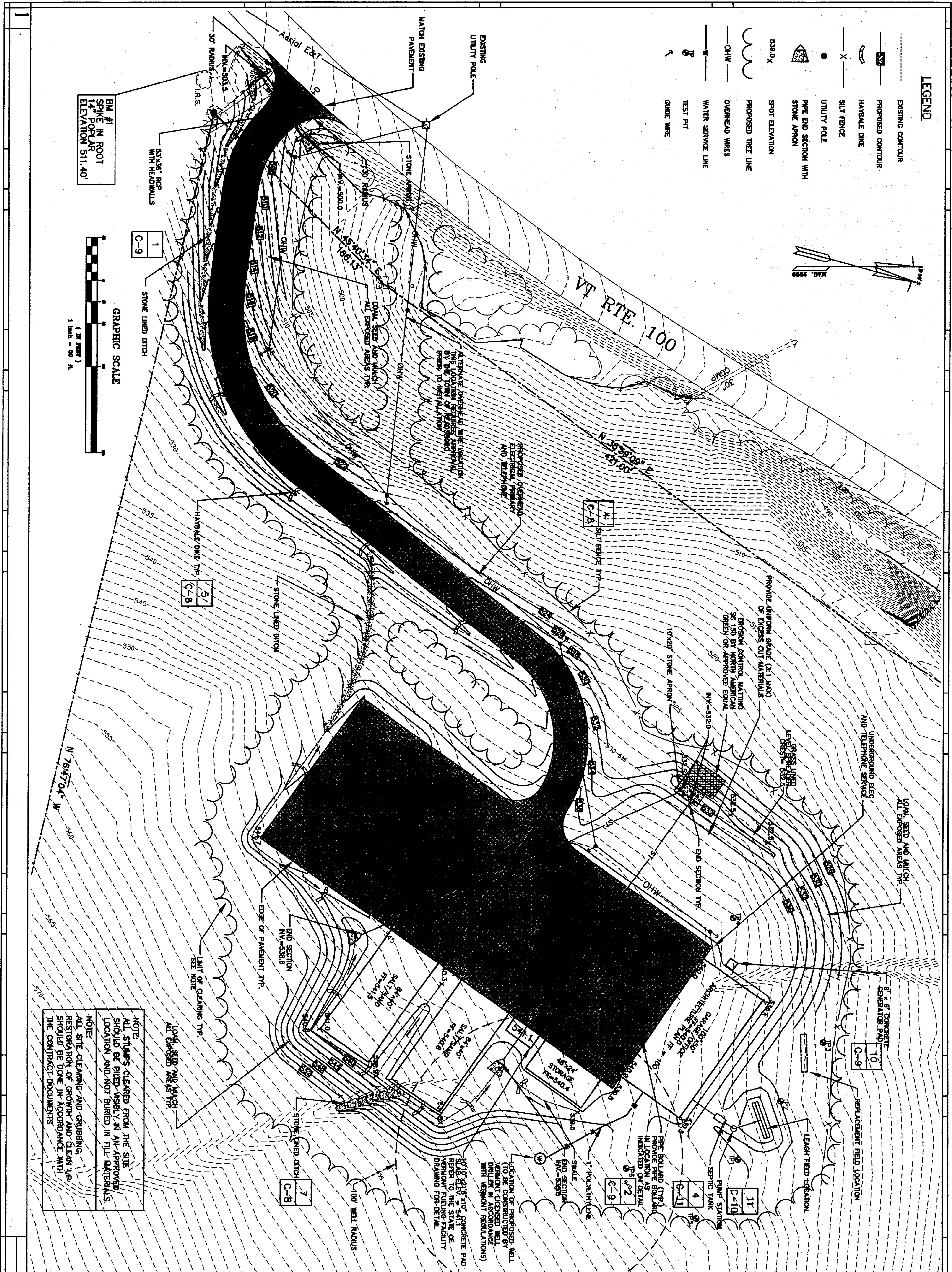
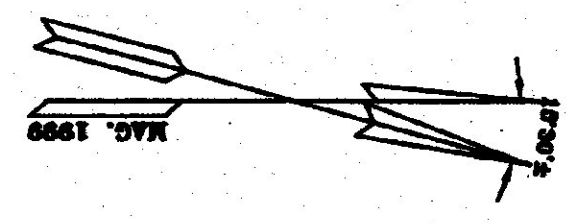

BM #1 IN ROOT
14 POPULAR
ELEVATION 511.40'

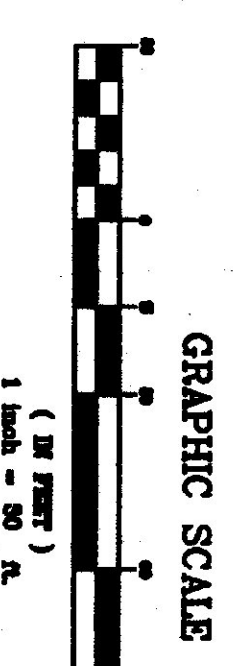

NOTE:
ALL STUMPS CLEARED FROM THE SITE SHOULD BE PILED VISIBLY IN AN APPROVED LOCATION AND NOT BURIED IN FILL MATERIALS.

NOTE:
ALL SITE CLEANING AND GRUBBING RESTORATION OF GROWTH AND CLEAN UP SHOULD BE DONE IN ACCORDANCE WITH THE CONTRACT DOCUMENTS.

BID DOCUMENTS
DO NOT REVISE
January 24, 2002

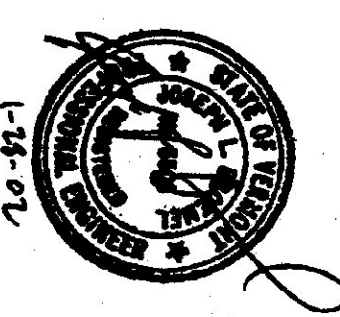

DH
Dufresne-Henry
North Springfield, Vermont
Tel: 802.885.2200
www.dufresnehenry.com

Project: State of Vermont
Landscape Architecture
1100 North Main Street, Suite 100
North Springfield, Vermont 05156 USA
Tel: 802.885.2200
www.dufresnehenry.com

READSBORO
HIGHWAY
GARAGE PROJECT
READSBORO, VERMONT

SITE PLAN

0000
PROJECT NUMBER

DATE
21 OCTOBER 2001

C1

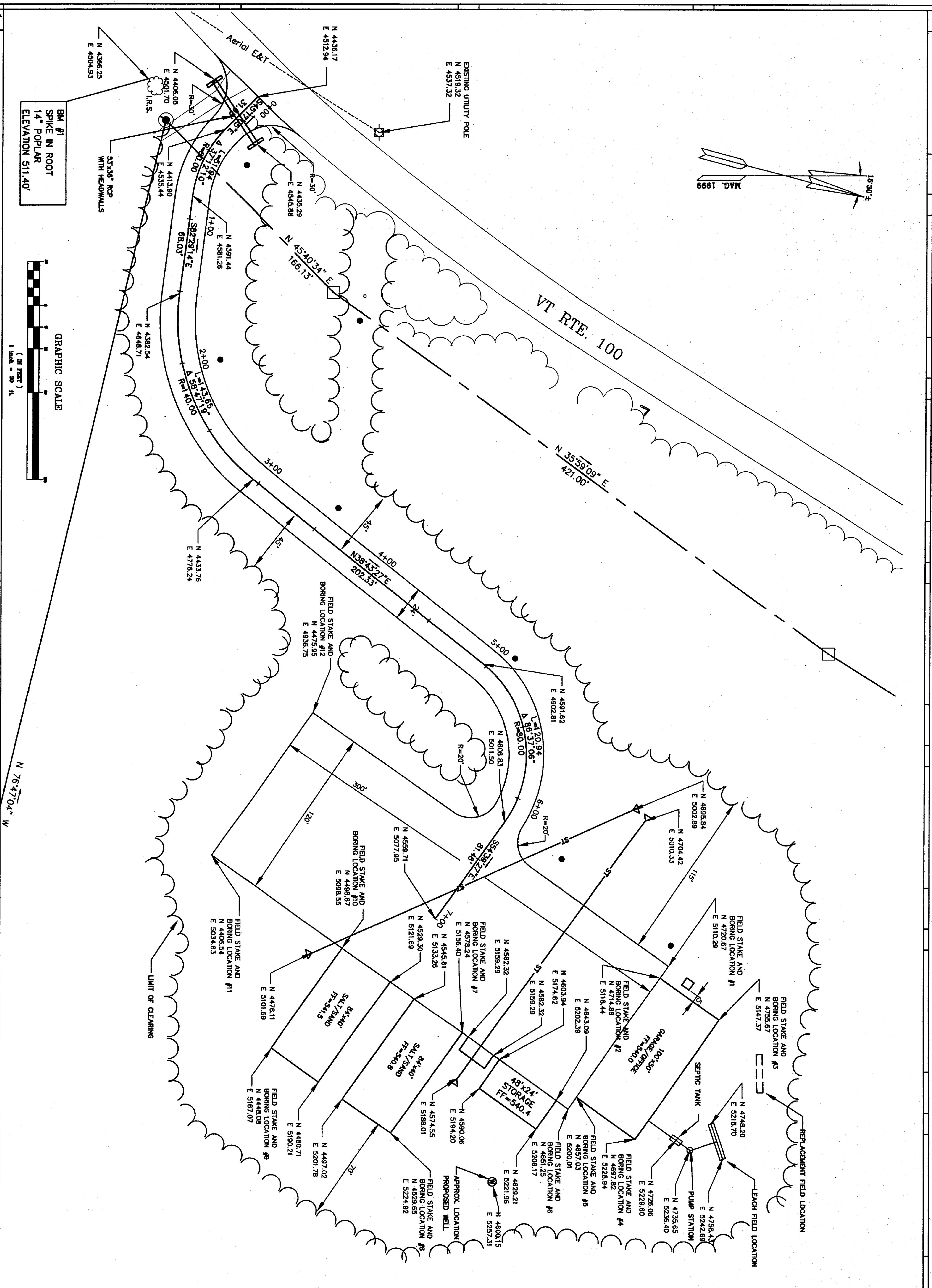
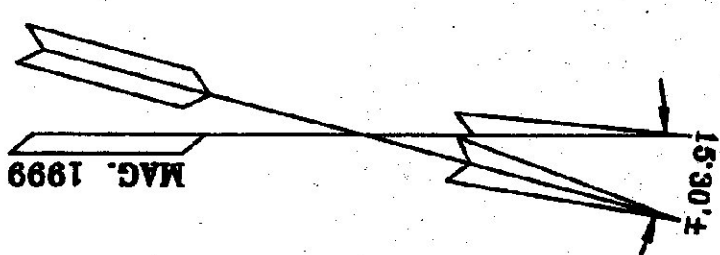

BM #1
SPIKE IN ROOT
14" POPLAR
ELEVATION 511.40'

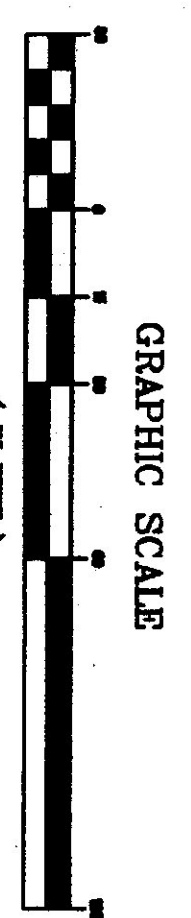

The Design Studio of
LineSonic Architecture
14 Oak Hill Vermont Vermont 05476 USA
Tel: (802) 253-1238 www.line-sonic.com

DH
Dufresne-Henry
North Stratford, Vermont
Tel: (802) 884-2241 • Fax: (802) 884-2242
www.dufresne-henry.com

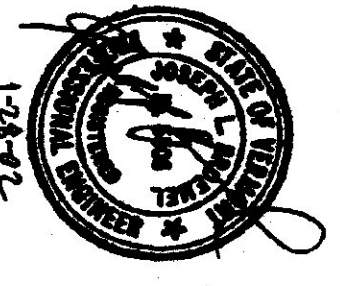

BID DOCUMENTS
DO NOT REVISE
January 24, 2002

NO.	REVISION PER VERRANS COMMENTS	DATE
1	REVISION PER VERRANS COMMENTS	1/24/2002

READSBORO
HIGHWAY
GARAGE PROJECT
READSBORO, VERMONT
LAYOUT PLAN
SHEET TITLE

0000
PROJECT NUMBER
25 OCTOBER 2001
DRAWN DATE
C2
DESIGN NUMBER

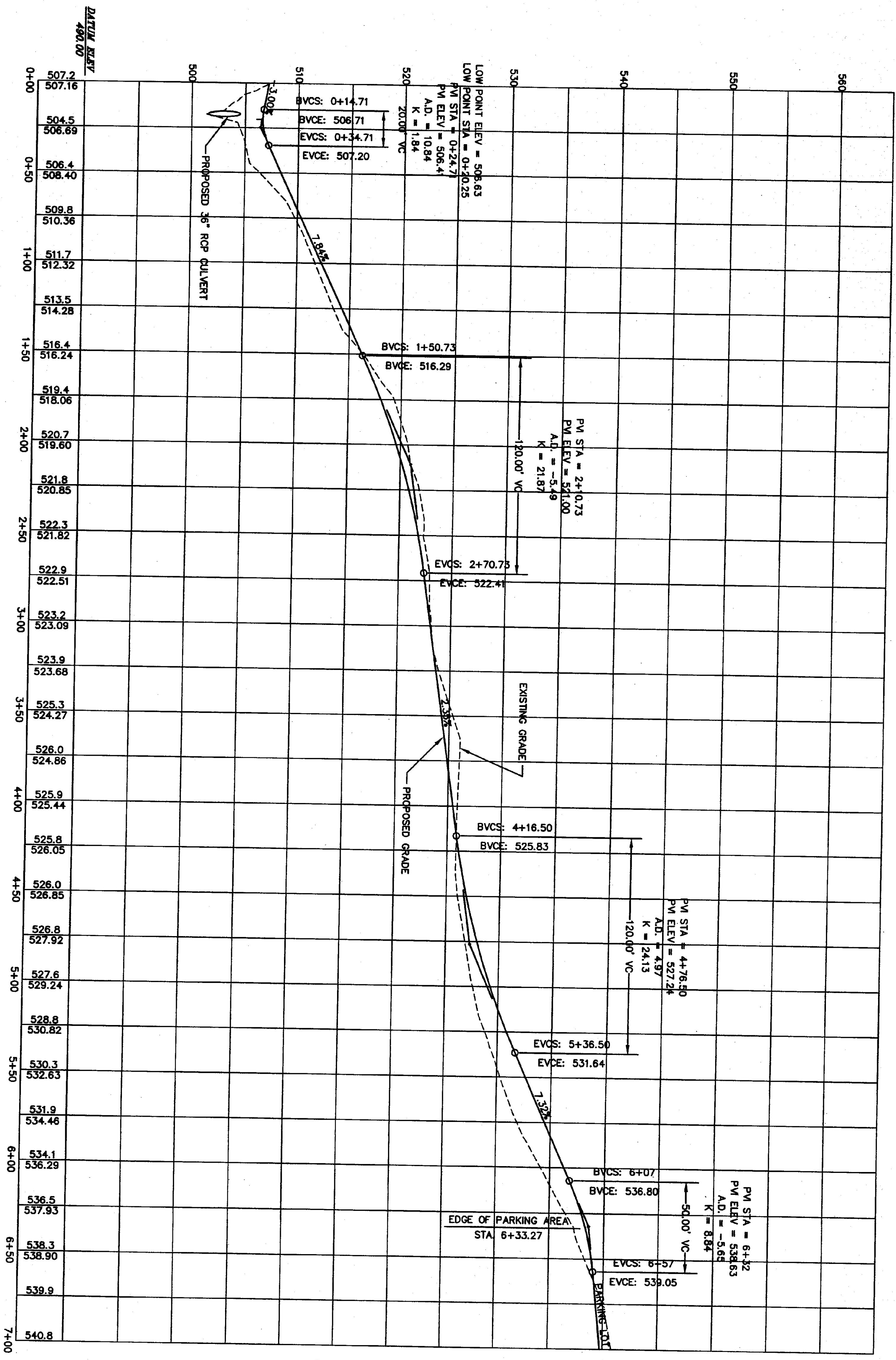

PROPOSED CENTERLINE PROFILE OF ACCESS ROAD

SCALE: HORIZ. 1"=30'
VERT. 1"=5'

1st Design Consultant
Limeshine Architecture
 110 Main Street, Vermont 05611 USA
 802.253.7133
 www.limeshine.com

DH
Dufresne-Henry
 North Springfield, Vermont
 Tel: (802) 888-8888 or Fax: (802) 888-8888
 www.dufresnehenry.com



BID DOCUMENTS
 DO NOT REVISE
 January 24, 2002

NO.	REVISIONS PER VITRANS COMMENTS	DATE
1	REVISED PER VITRANS COMMENTS	1/24/2002

READSBORO VERMONT
 READSBORO
 HIGHWAY
 GARAGE PROJECT

ROAD PROFILE
 SHEET TITLE

0000
 PROJECT NUMBER
 25 OCTOBER 2001
 DRAWING DATE
03
 SHEET NUMBER

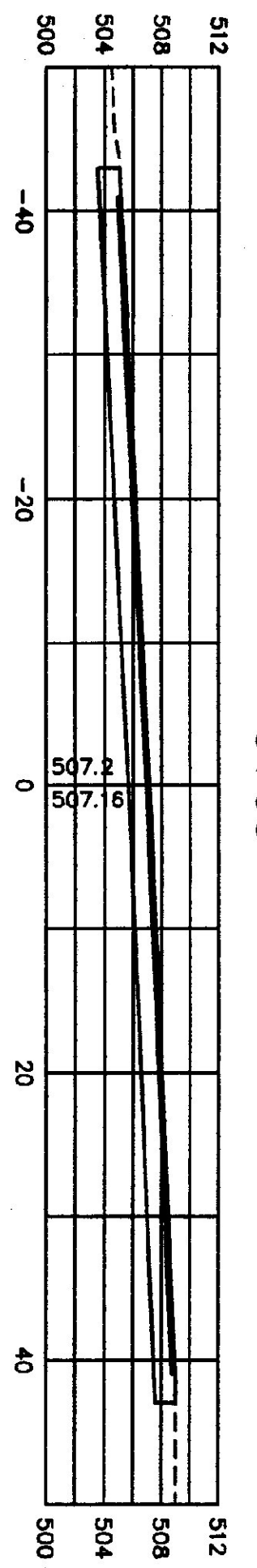
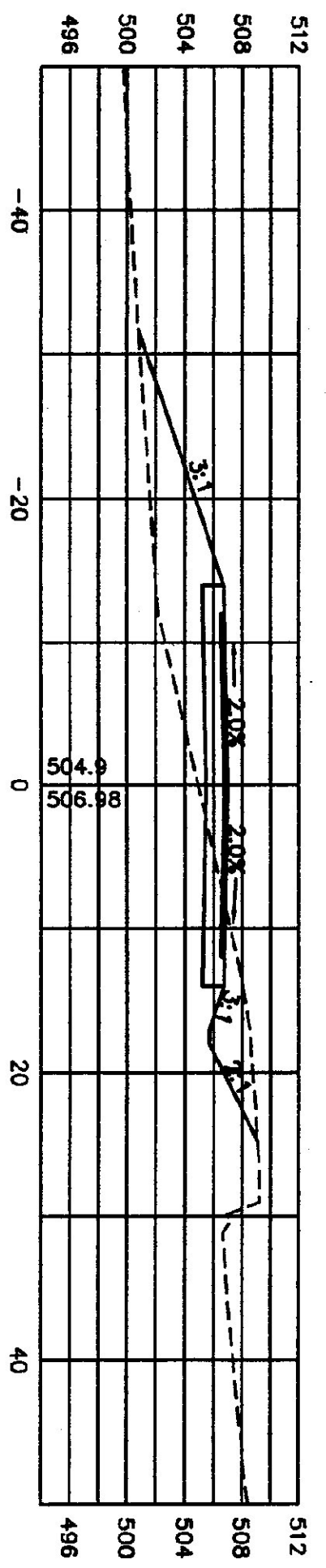
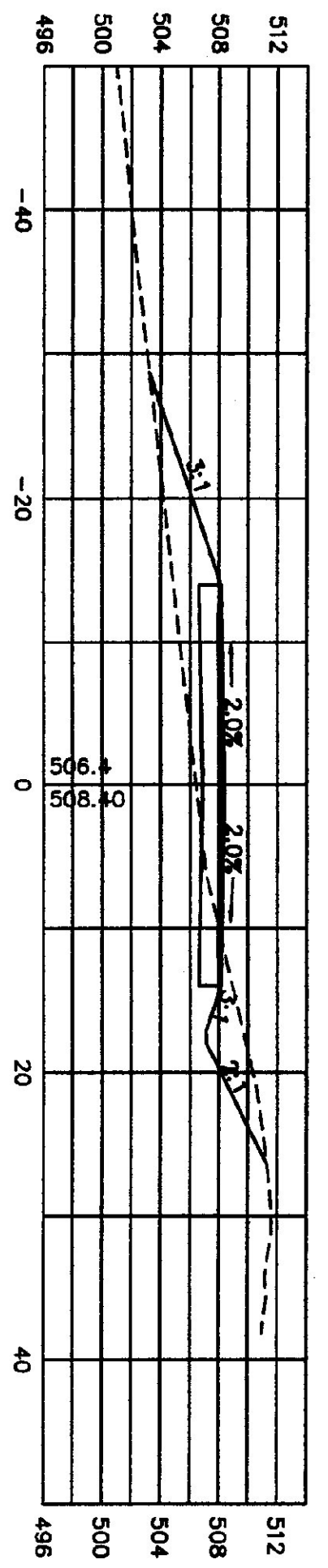
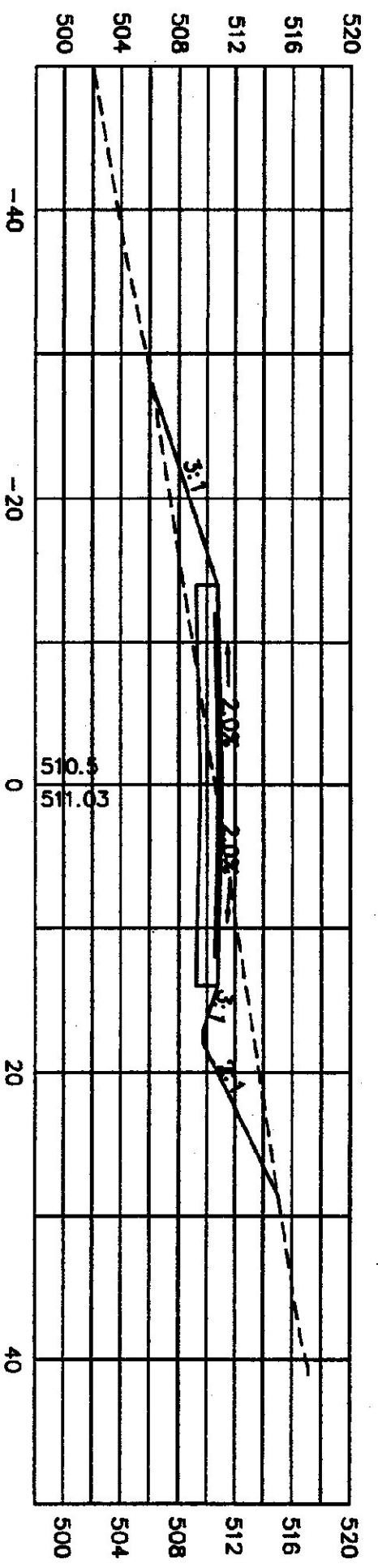
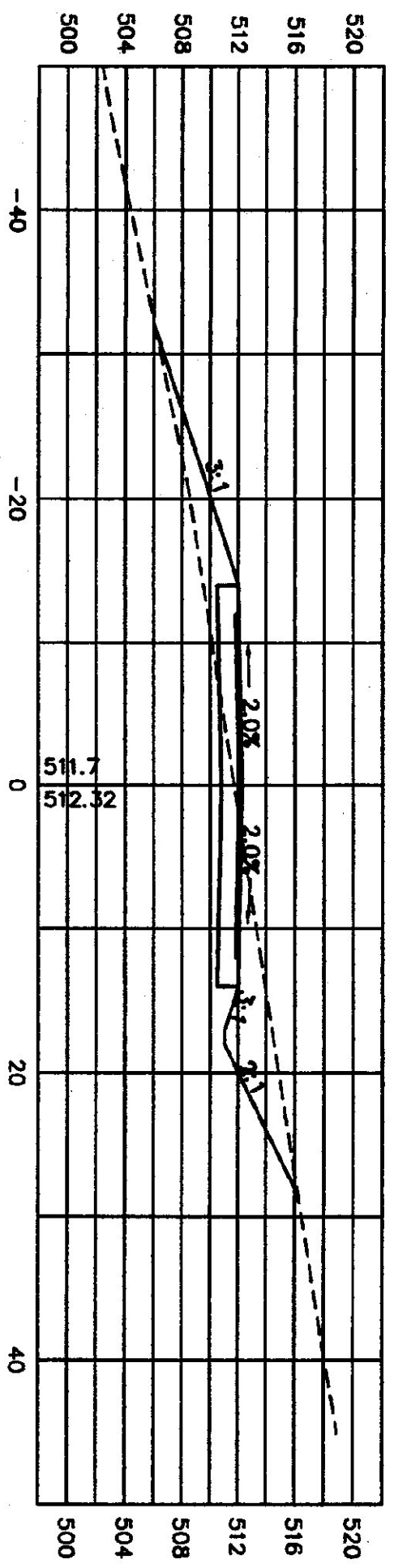
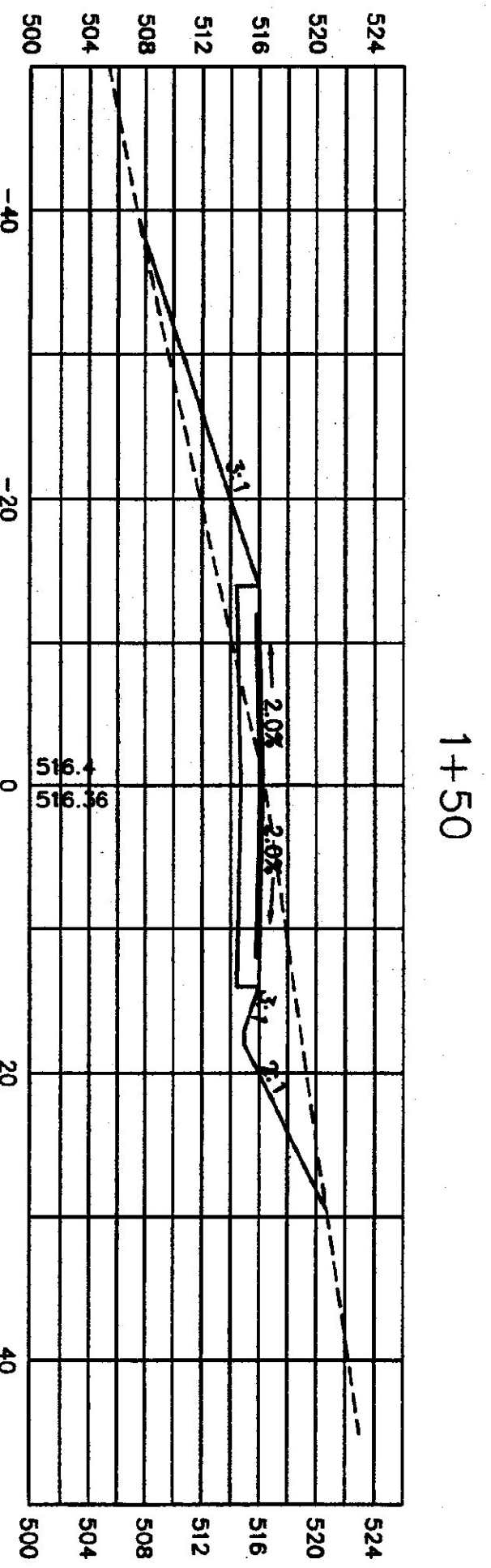

PROPOSED CENTERLINE X-SECTIONS OF ACCESS ROAD

SCALE: HORIZ. 1"=10'
VERT. 1"=10'

Dr. Don Shauf
LineSync Architecture
11 Oak Hill Village, Vermont 05318 USA
VERMONT 15708 www.linesync.com



BID DOCUMENTS
DO NOT REVISE
January 24, 2002

NO.	REVISION PER VISUAL COMMENTS	DATE
1	REVISION PER VISUAL COMMENTS	1/24/2002

READSBORO
HIGHWAY
GARAGE PROJECT
READSBORO, VERMONT

ROAD CROSS SECTIONS
SHEET TITLE

PROJECT NUMBER: 0000
DATE: 25 OCTOBER 2001
DRAWING DATE: 25 OCTOBER 2001
SHEET DESIGNATION: C4

PT 2+95.27

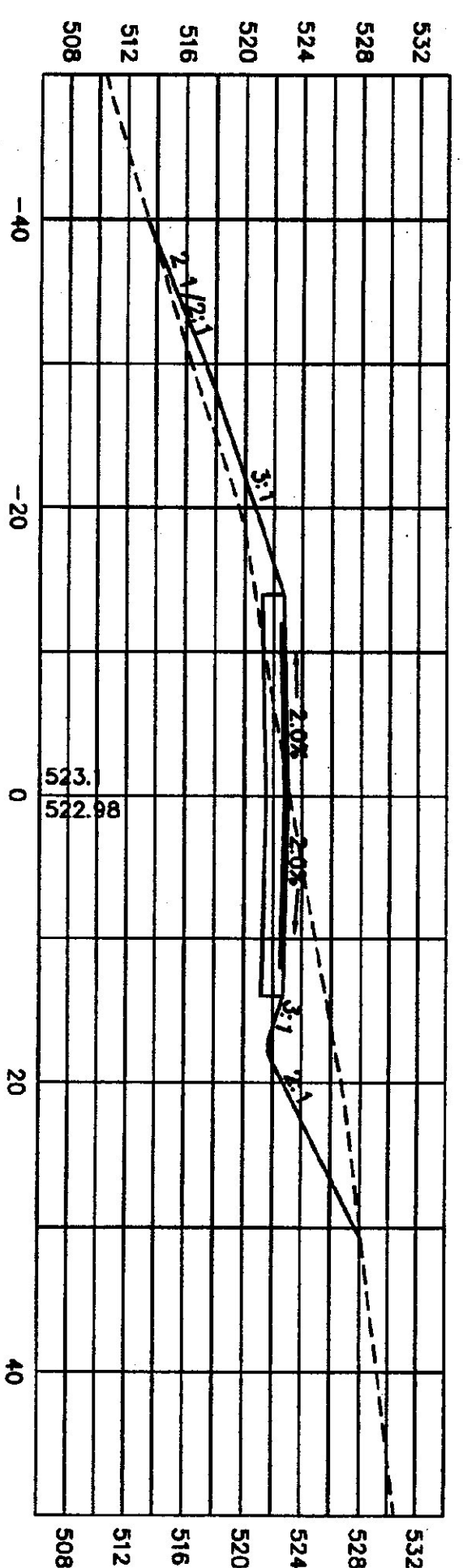

2+50

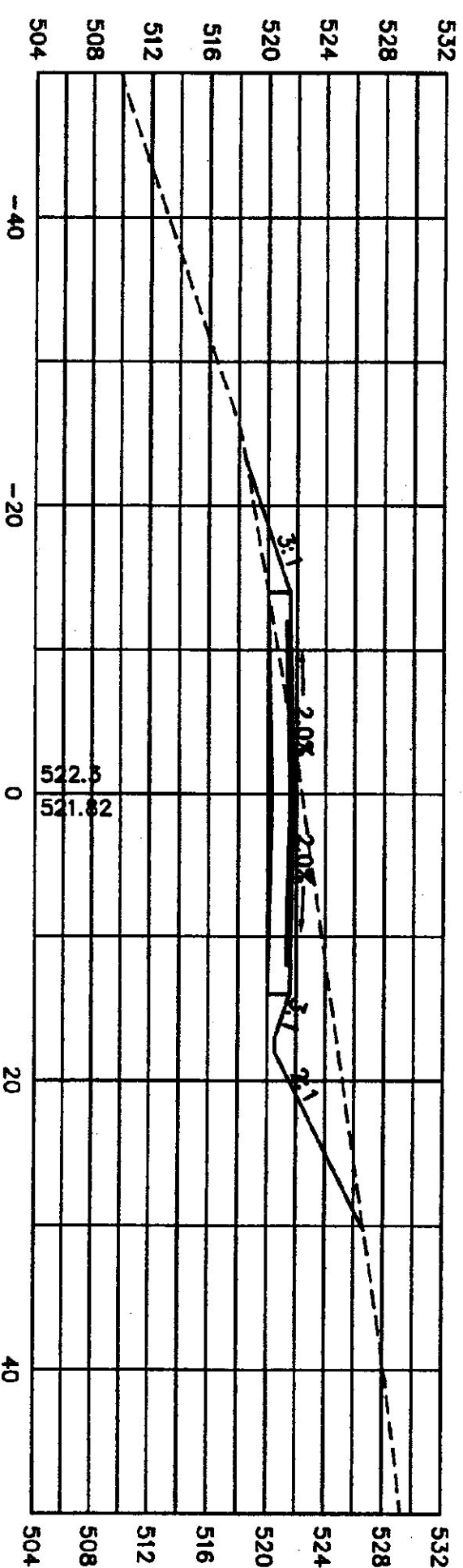

2+00

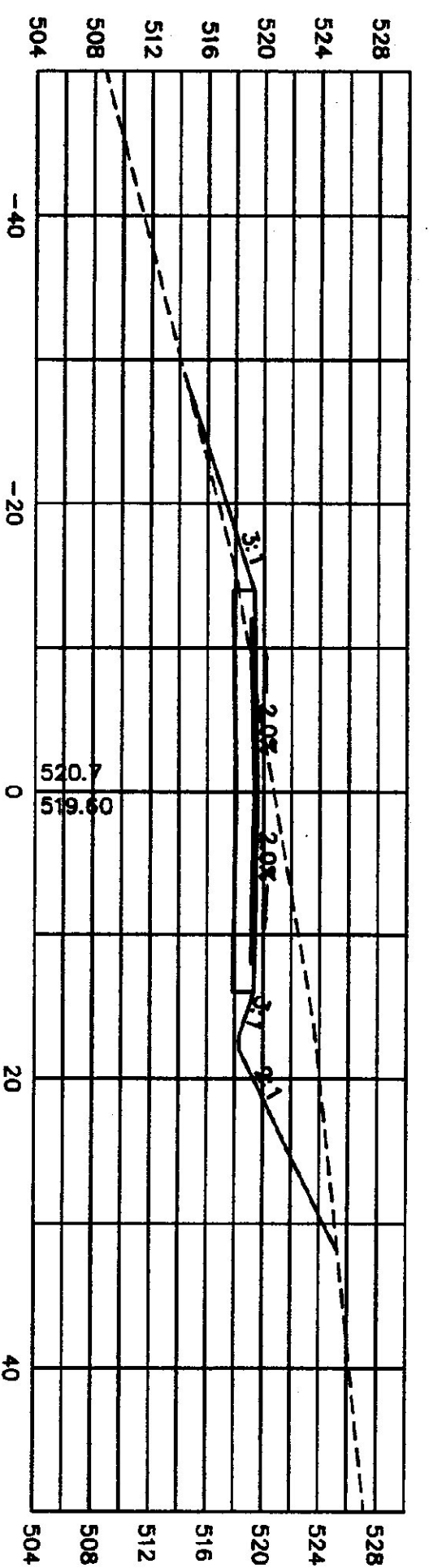

PC 1+51.63

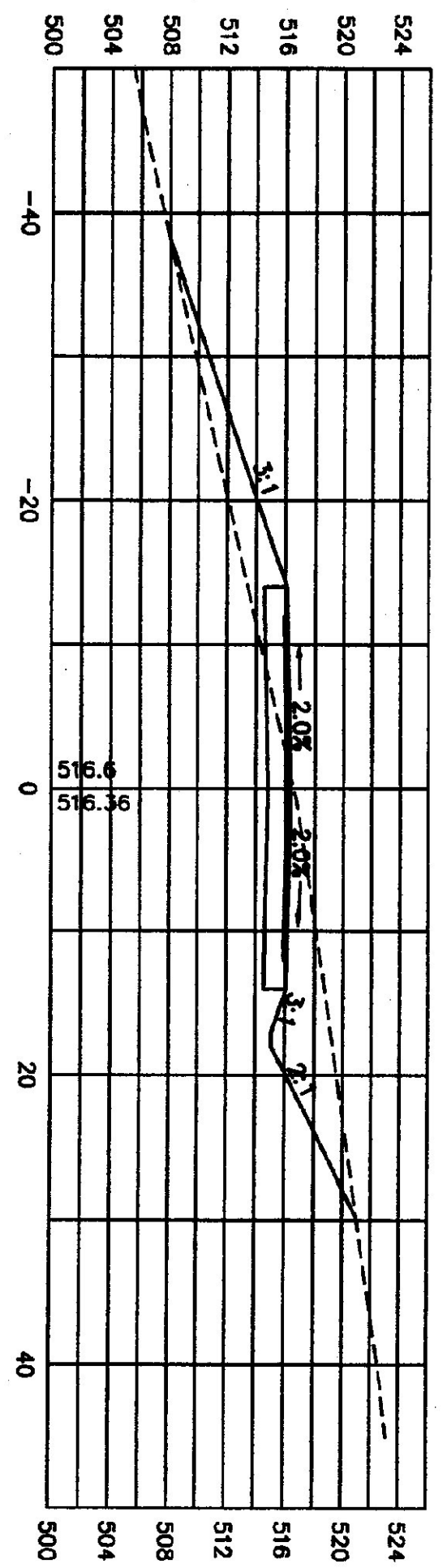

PROPOSED CENTERLINE X-SECTIONS OF ACCESS ROAD

SCALE: HORIZ. 1"=10'
VERT. 1"=10'

The Design Studio of
LineSonic Architecture
11 Clark Hill Way, Vergennes, Vermont 05491
Tel: (802) 244-5329 / Fax: (802) 244-5328
www.line-sonic.com

CLIENT



BID DOCUMENTS
DO NOT REVISE
January 24, 2002

NO.	REVISION PER VPI/MS COMMENTS	DATE
1	REVISED PER VPI/MS COMMENTS	1/24/2002

READSBORO
HIGHWAY
GARAGE PROJECT
READSBORO, VERMONT

ROAD CROSS SECTIONS
SHEET TITLE

PROJECT NUMBER: 0000
DATE: 25 OCTOBER 2001
DRAWN BY: [Signature]
CHECKED BY: [Signature]
SHEET NUMBER: C5

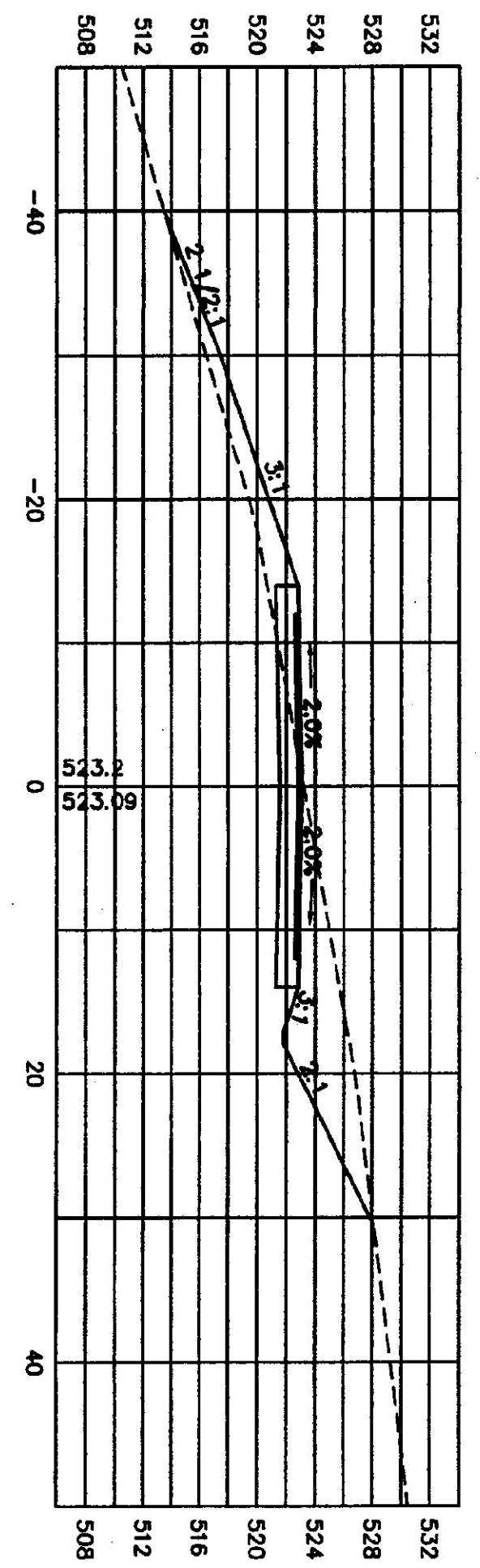
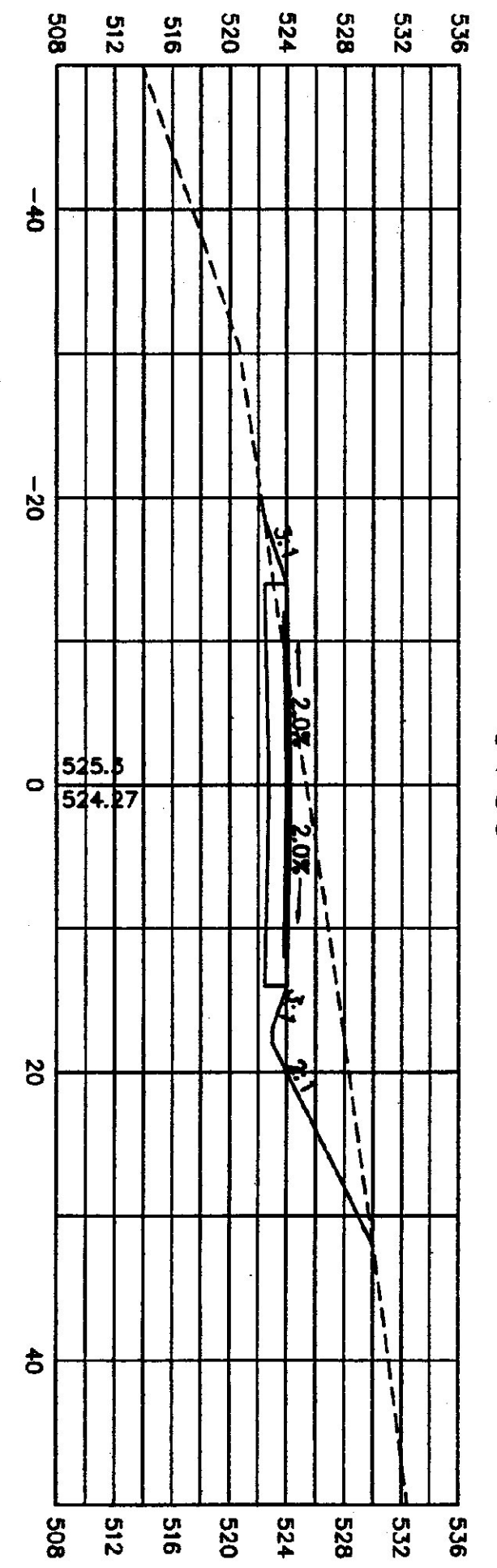
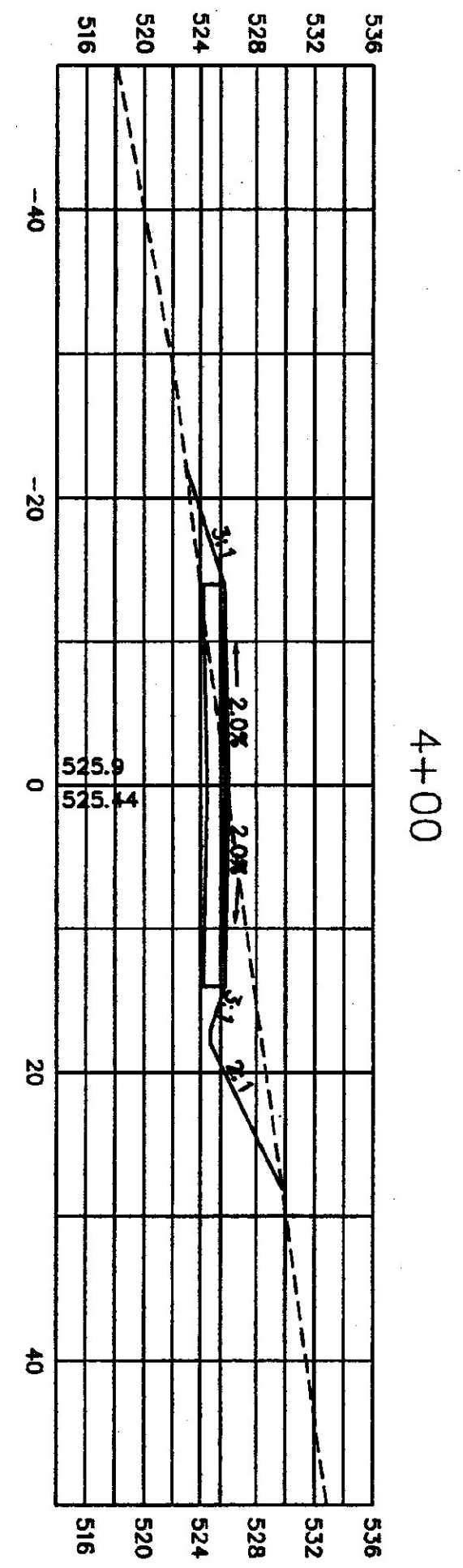
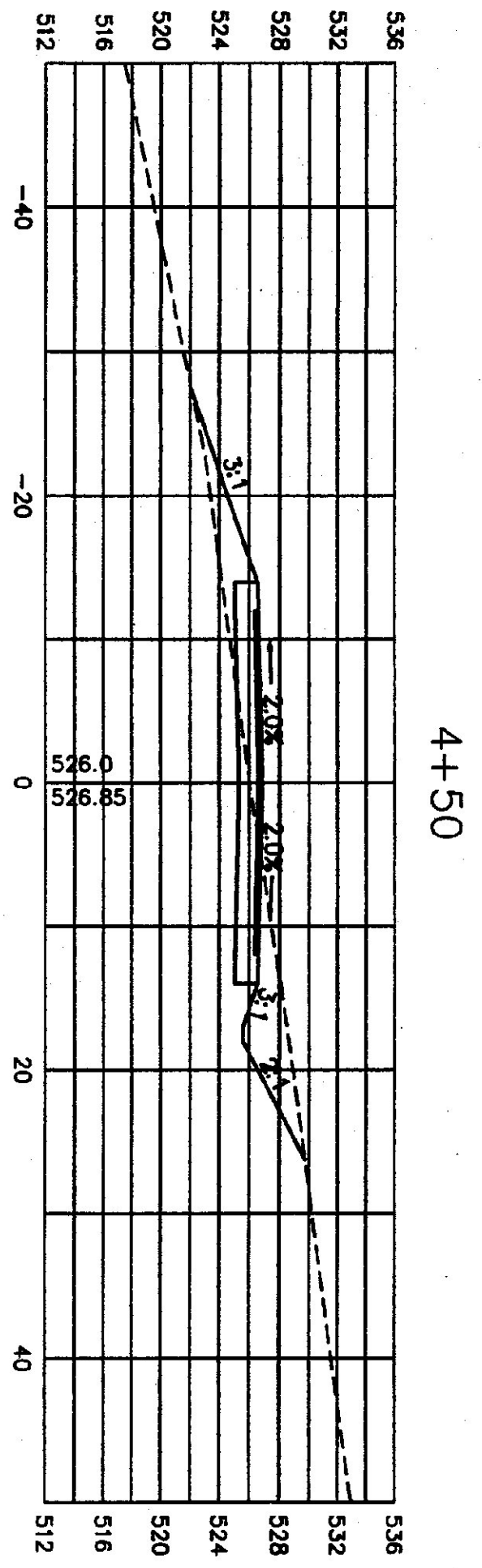

PROPOSED CENTERLINE X-SECTIONS OF ACCESS ROAD
 SCALE: HORIZ. 1"=10'
 VERT. 1"=10'

The Design Studio of
Linesync Architecture
 11 Canal Street, Vermont 05501 USA
 V. 802.444.5351 / F. 802.444.5352 www.linesync.com

DH
 Dufresne-Henry
 North Springfield, Vermont
 Tel. (802) 266-2211 • Fax (802) 266-2200
 www.dufresne-henry.com

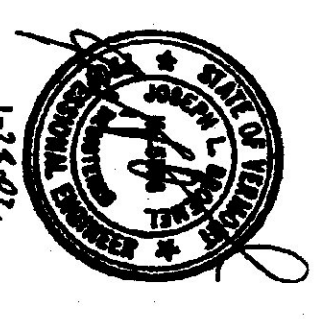

BID DOCUMENTS
 DO NOT REVISE
 January 24, 2002

NO.	REVISED PER VTRAINS COMMENTS	DATE
1	REVISED PER VTRAINS COMMENTS	1/24/2002

READSBORO
 HIGHWAY
 GARAGE PROJECT
 READSBORO, VERMONT

ROAD CROSS SECTIONS
 SHEET NO. 0000

PROJECT NUMBER: 0000
 DATE: 25 OCTOBER 2001
 DRAWN BY: [Signature]
 CHECKED BY: [Signature]
C6

6+33.27 EDGE OF PARKING LOT

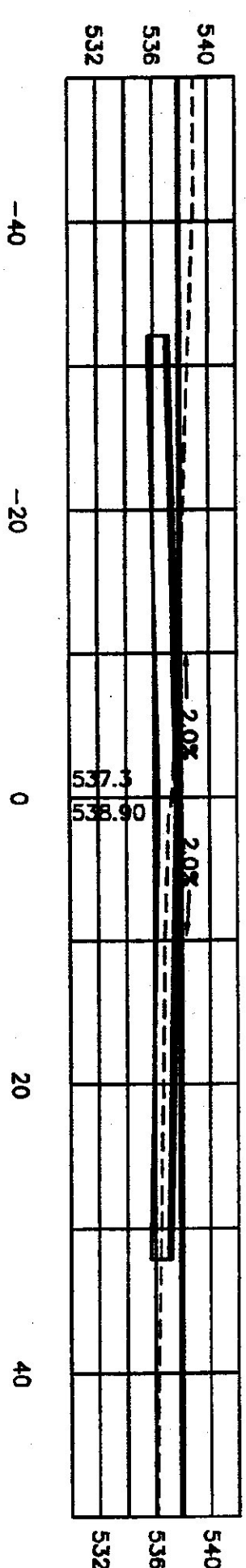

PT 6+18.55

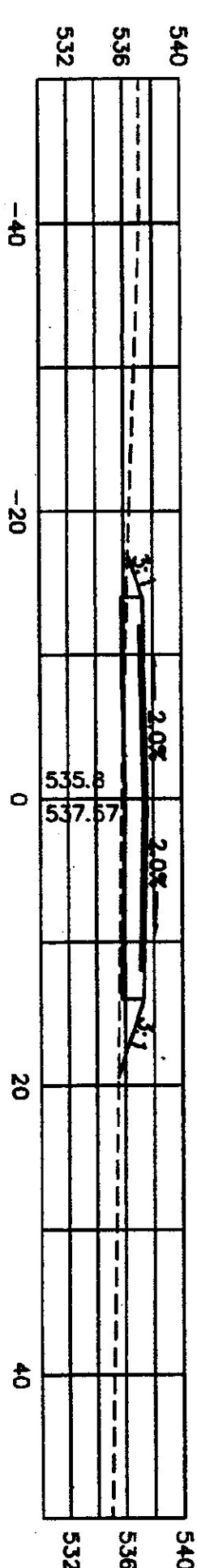

6+00

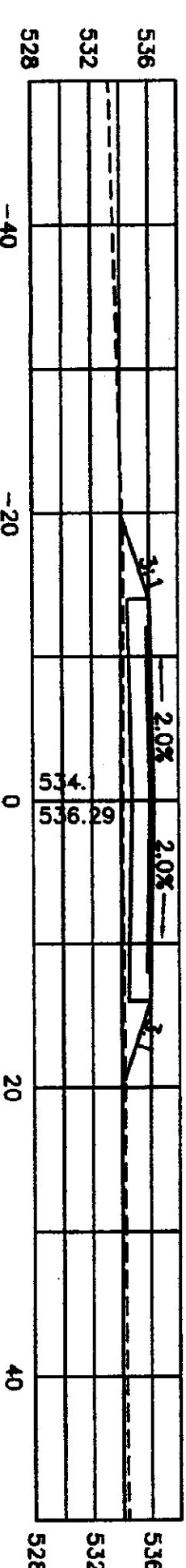

5+50

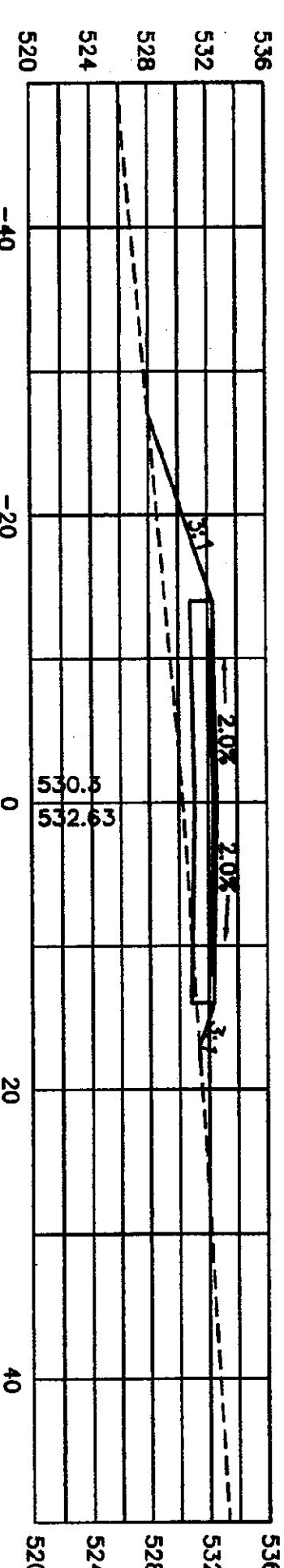

5+00

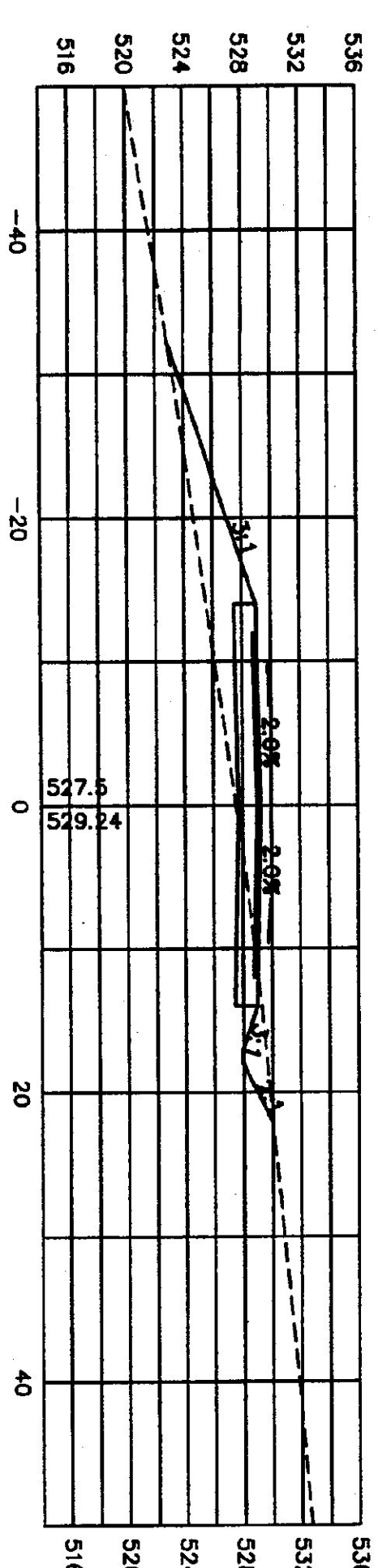

PC 4+97.61

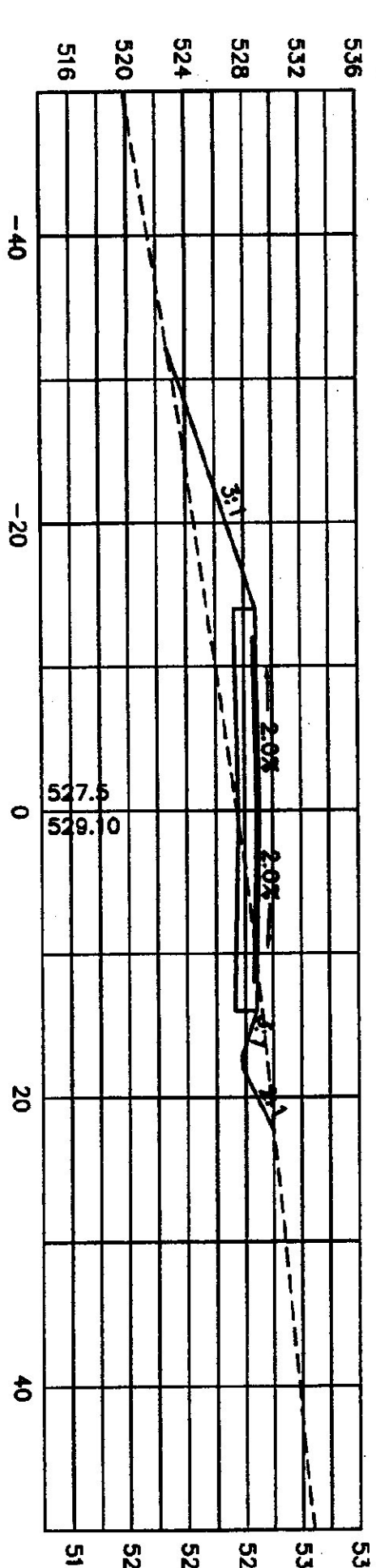

PROPOSED CENTERLINE X-SECTIONS OF ACCESS ROAD

SCALE: HORIZ. 1"=10'
VERT. 1"=10'

The Design Studio of
Linsync Architecture
14 Oak Hill Village, Vermont 05359 USA
TEL: 802.464.2329 FAX: 802.464.2328
WWW.LINSYNCA.COM

DH
Dufresne-Henry
North Ferrisburgh, Vermont 05359
TEL: (802) 888-8888 FAX: (802) 888-8888
WWW.DUFRESNEHENRY.COM



BID DOCUMENTS
DO NOT REVISE
January 24, 2002

NO.	REVISIONS PER VTRAMS COMMENTS	DATE
1	REVISION PER VTRAMS COMMENTS	1/24/2002

READSPORO, VERMONT
READSPORO HIGHWAY GARAGE PROJECT

ROAD CROSS SECTIONS
SHEET TITLE

0000 PROJECT NUMBER
25 OCTOBER 2001 DRAWING DATE
C7 SHEET IDENTIFICATION

GENERAL NOTES AND SPECIFICATIONS FOR EROSION CONTROL

1. THE CONTRACTOR IS RESPONSIBLE FOR WATER CONTROL DURING ALL PHASES OF CONSTRUCTION. THE CONTRACTOR SHALL MAINTAIN ALL EXISTING WATERWAYS AND SHALL BE RESPONSIBLE FOR THE PROTECTION OF ALL EXISTING WATERWAYS. THE CONTRACTOR SHALL BE RESPONSIBLE FOR THE PROTECTION OF ALL EXISTING WATERWAYS. THE CONTRACTOR SHALL BE RESPONSIBLE FOR THE PROTECTION OF ALL EXISTING WATERWAYS.
2. THE CONTRACTOR IS RESPONSIBLE FOR THE PROTECTION OF ALL EXISTING WATERWAYS. THE CONTRACTOR SHALL BE RESPONSIBLE FOR THE PROTECTION OF ALL EXISTING WATERWAYS. THE CONTRACTOR SHALL BE RESPONSIBLE FOR THE PROTECTION OF ALL EXISTING WATERWAYS.
3. THE CONTRACTOR IS RESPONSIBLE FOR THE PROTECTION OF ALL EXISTING WATERWAYS. THE CONTRACTOR SHALL BE RESPONSIBLE FOR THE PROTECTION OF ALL EXISTING WATERWAYS. THE CONTRACTOR SHALL BE RESPONSIBLE FOR THE PROTECTION OF ALL EXISTING WATERWAYS.
4. GENERAL CONSTRUCTION SEQUENCE - PHASE 1
 - A. INITIAL SLOPE AND/OR HAY BALE BARBERS AS SHOWN ON THE PLANS.
 - B. CONSTRUCT DETENTION BASINS, CONSTRUCT TEMPORARY DIVERSION SWALES OR BARRIERS THAT DIRECT RUNOFF TO THE BASINS.
 - C. STORM PIPES AND STORM INLET STRUCTURES, THE AMOUNT OF OPEN AREA AT ANY TIME SHALL BE LIMITED TO 4 AC MAXIMUM.
 - D. CONSTRUCT SLOPE AND HAY BALE BARBERS AT AREA DRAIN INLETS.
 - E. PROVIDE TEMPORARY SEED AND MULCH ON OPEN AREAS WHERE WORK WILL BE CONDUCTED. SEED AND MULCH SHALL BE APPLIED TO ALL EXPOSED AREAS.
 - F. CONSTRUCT BALDINGS, WALKING PATHS, AND PARKING LOT.
 - G. FINAL GRADE PLACING FIELDS AND BASEBALL DIAMOND.
 - H. ESTABLISH PERMANENT VEGETATION AND OTHER LANDSCAPING AS REQUIRED.
 - I. REMOVE TEMPORARY EROSION CONTROL MEASURES IN GIVEN AREAS AS STABILIZATION IS ACHIEVED.
 - J. REMOVE ALL ACCUMULATED SEDIMENT FROM THE DETENTION BASINS AND ENSURE THE DRAINS ARE NOT BLOCKED.

5. SEEDING AND MULCHING (NOT FOR WETLAND RESTORATION)
 - A. ALL AREAS WHICH WILL REMAIN OPEN SHALL BE SEEDING AND MULCHED WITH PERMANENT SEED AND MULCH AS SOON AS PRACTICAL. ONCE FINAL GRADING HAS BEEN DONE.
 - B. SOIL SAMPLES MAY BE SOIL TO THE COUNTY EXTENSION SERVICE FOR ANALYSIS TO DETERMINE THE PROPER SEED MIXTURE AND FERTILIZER REQUIREMENTS.
 - C. THE FOLLOWING PROCEDURES SHALL BE FOLLOWED FOR TEMPORARY SEEDING:
 - (1) APPLY LIME AT A RATE OF 75 TO 100 POUNDS PER 1000 SQUARE FEET, APPROPRIATE TO TOP TWO INCHES OF SOIL.
 - (2) APPLY FERTILIZER AT A RATE OF 30 POUNDS PER 1000 SQUARE FEET, APPROPRIATE TO TOP TWO INCHES OF SOIL.
 - (3) APPLY SEED MIXTURE AT A RATE OF TWO POUNDS PER 1000 SQUARE FEET, EVENLY IN TWO INTERSECTING DIRECTIONS, RAKE UNLIT.
 - (4) APPLY MULCH MATERIAL WITHIN 24 HOURS AFTER SEEDING IN ACCORDANCE WITH THE FOLLOWING:
 - (1) HAY OR STRAW: APPLICATION RATE - 75 TO 100 SQUARE FEET PER 1000 SQUARE FEET, SPREAD BY HAND OR WITH MACHINE ANCHOR ON SLOPES AND WHERE SUBJECT TO BLUING OR SLUFFING.
 - (2) WOOD CHIPS: APPLICATION RATE - TWO TO SIX INCHES DEEP.
 - (3) USE FOR TREE AND SHRUB PLANTING.
 - D. ANCHOR MULCH ON ALL SLOPES EXCEEDING SIX AND OTHER AREAS AS REQUIRED USING ONE OF THE FOLLOWING METHODS:
 - (1) ASPHALT EMULSION: APPLY ASPHALT EMULSION AT A RATE OF 3.5 TO 4.5 GALLONS PER 1000 SQUARE FEET. MULCH MAY BE PLACED ON TOP OF ASPHALT EMULSION. MULCH EQUIPMENT SHALL BE USED TO APPLY EMULSION.
 - (2) MULCH NETTING: SPREAD OVER LOOSE MULCH AND PIN TO THE SOIL IN ACCORDANCE WITH THE MANUFACTURER'S INSTRUCTIONS.
 - E. WHEN TEMPORARY SEEDING CANNOT BE ACCOMPLISHED TO HAVE ESTABLISHED COVER WITHIN 90 DAYS OF MULCHING, THE DISTURBED AREAS SHALL BE COVERED WITH 8 INCHES OF MULCH FOR THE WINTER.
6. MAINTENANCE OF EROSION CONTROL STRUCTURES
 - A. HAY BALES SHALL BE REPLACED WHEN THEY BECOME CLOGGED WITH SOIL PARTICLES OR AS DIRECTED BY THE OWNER/SUPERVISOR.
 - B. WHEN THE SEDIMENT ACCUMULATION REACHES A DEPTH OF 12 INCHES BEHIND THE SILT FENCE IT SHALL BE CLEARED OF.
 - C. REPAIR ALL DAMAGES CAUSED BY SOIL EROSION OR CONSTRUCTION EQUIPMENT AT OR BEFORE THE END OF EACH WORKING DAY.
 - D. ALL EROSION CONTROL FEATURES SUCH AS SILT FENCE AND HAY BALE DIKES MUST BE IN PLACE PRIOR TO THE GROUND FREEZING.
 - E. ALL DISTURBED AREAS OF THE SITE SHALL BE SEEDING AND MULCHED FROM OCTOBER 15 TO APRIL 15 REGARDLESS OF WHETHER FINAL GRADING HAS BEEN FINISHED. WORK MAY CONTINUE THROUGH THIS PERIOD IF THE FOLLOWING WINTER EROSION CONTROLS ARE IMPLEMENTED:
 - (1) OAT SEEDS SHALL BE SUBSTITUTED FOR ANY OTHER TEMPORARY ANNUAL GRASS SEEDS.
 - (2) ALL EXPOSED EARTH SHALL BE MULCHED WITH 6 INCHES OF HAY OR STRAW. SLOPES OVER SIX SHALL HAVE AN ADDITIONAL COVERING OF STYRENE FOAM OR ITS EQUIVALENT.
 - F. THE FOLLOWING MAINTENANCE ITEMS SHOULD BE PERFORMED SPECIFICALLY FOR THE VARIOUS EROSION CONTROL DEVICES:
 - (1) DIMENSION DIKE:
 - (A) MINIMUM INSPECTION FREQUENCY - WEEKLY.
 - (B) REMOVE ANY LOW BLOCKAGE CAUSED BY ICE OR SEDIMENT.
 - (2) MULCH:
 - (A) MINIMUM INSPECTION FREQUENCY - DAILY.
 - (B) REPAIR MULCH ON ANY AREA WHERE ORIGINAL MULCH COVER HAS BEEN LOST.
 - (3) HAY BALE DIKE:
 - (A) MINIMUM INSPECTION FREQUENCY - WEEKLY.
 - (B) REMOVE LAYERS OF SET AND SOIL FROM THE UPPER FACE OF THE DIKE. WHEN THE DIKE IS DAMAGED, REPAIR THE DIKE WITH HAY BALES. EXCESS SOIL SHOULD BE REMOVED OR RELOCATED TO ANOTHER AREA. ANY OTHER MATERIALS, INCLUDING MULCH, SHALL BE REMOVED FROM THE DIKE WHEN IT APPEARS THAT THE EXISTING DIKE IS NOT PERFORMING ADEQUATELY BY ITSELF.
 - (4) SILT FENCE:
 - (A) MINIMUM INSPECTION FREQUENCY - WEEKLY.
 - (B) CLEAN AND REMOVE ANY COLLECTED SEDIMENT BEFORE PREDICTED THAW OR RAINY PERIODS.

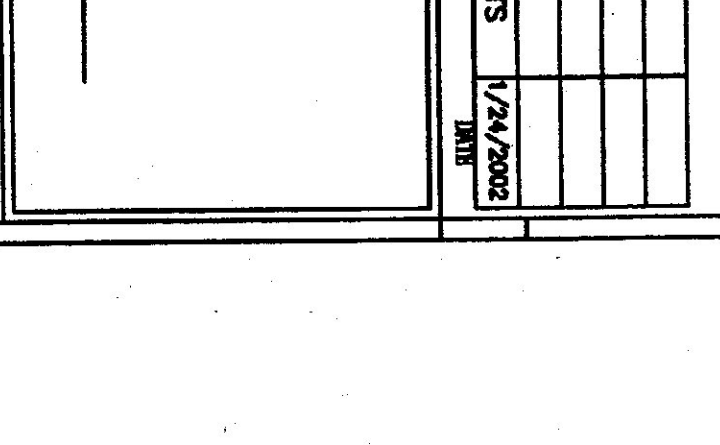
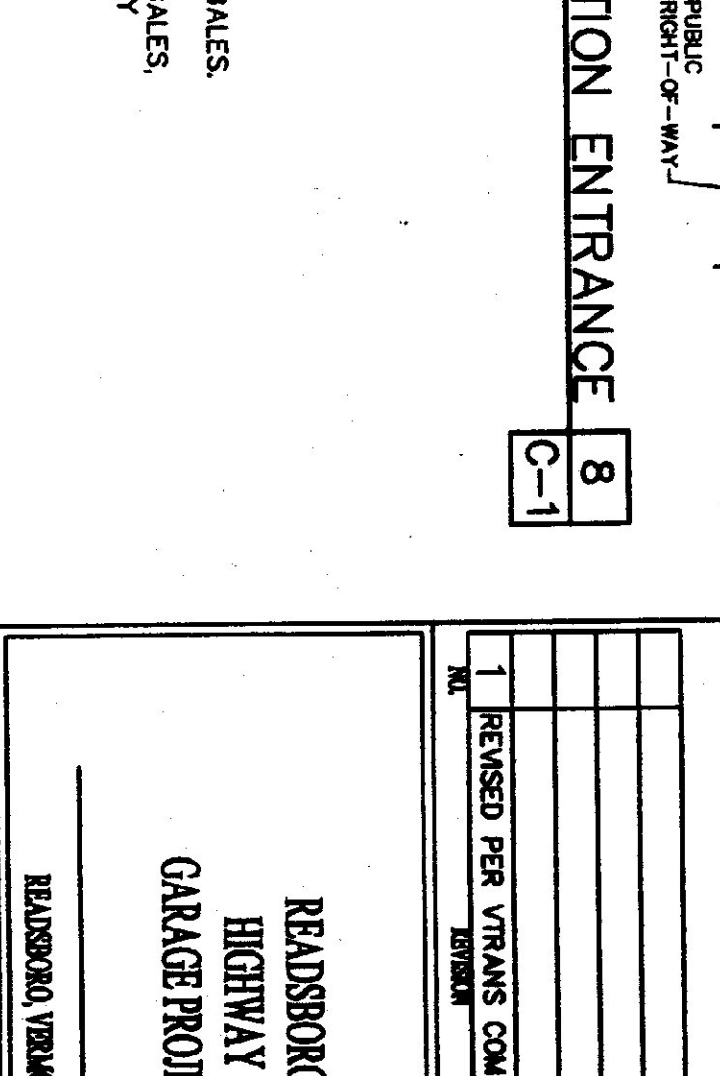
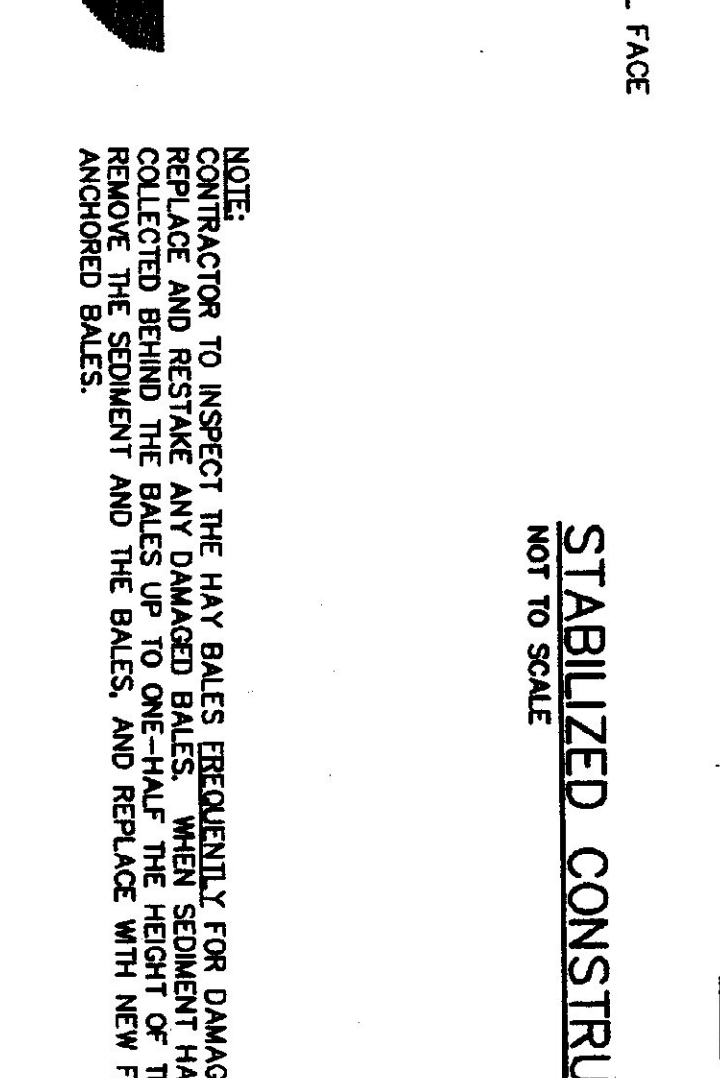
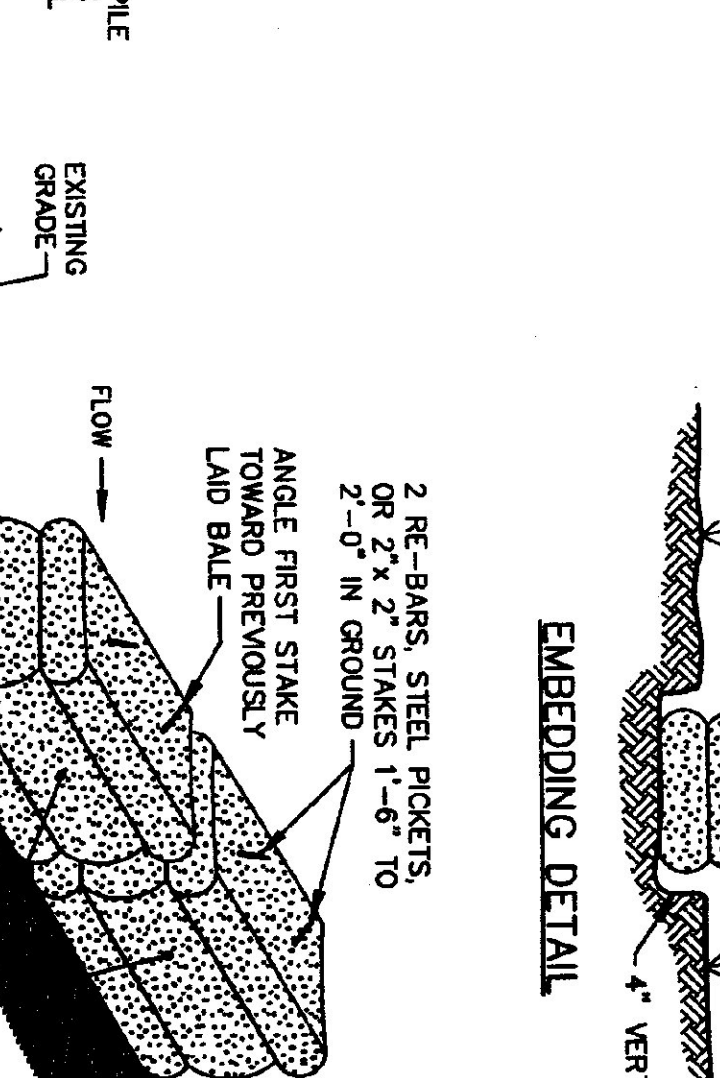
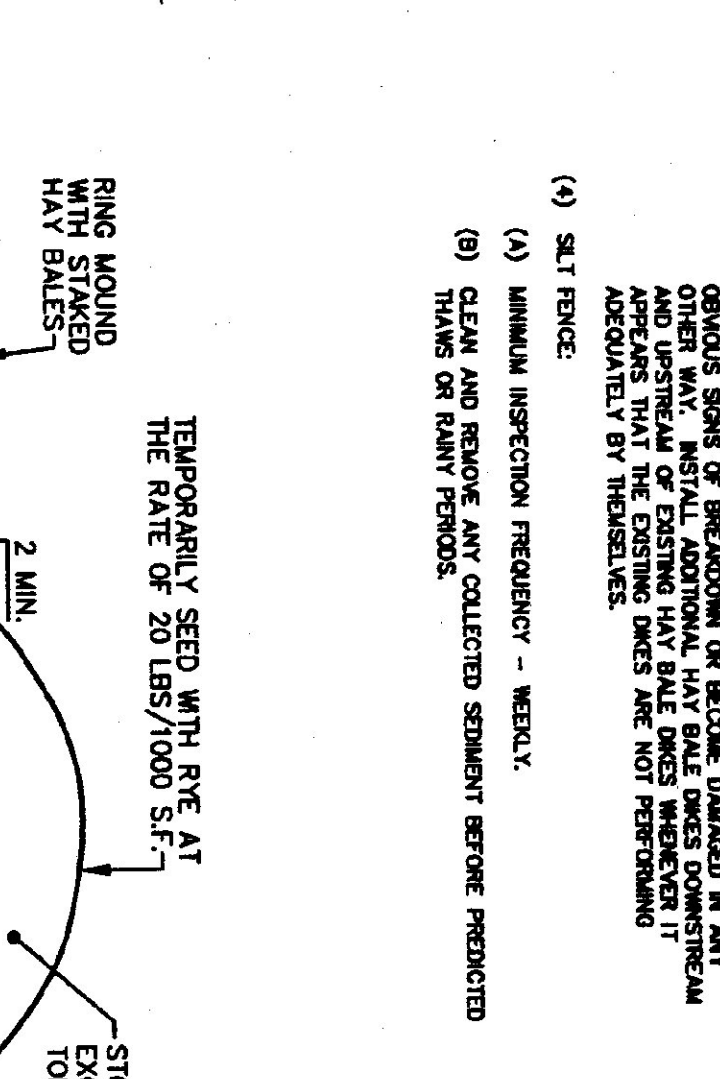
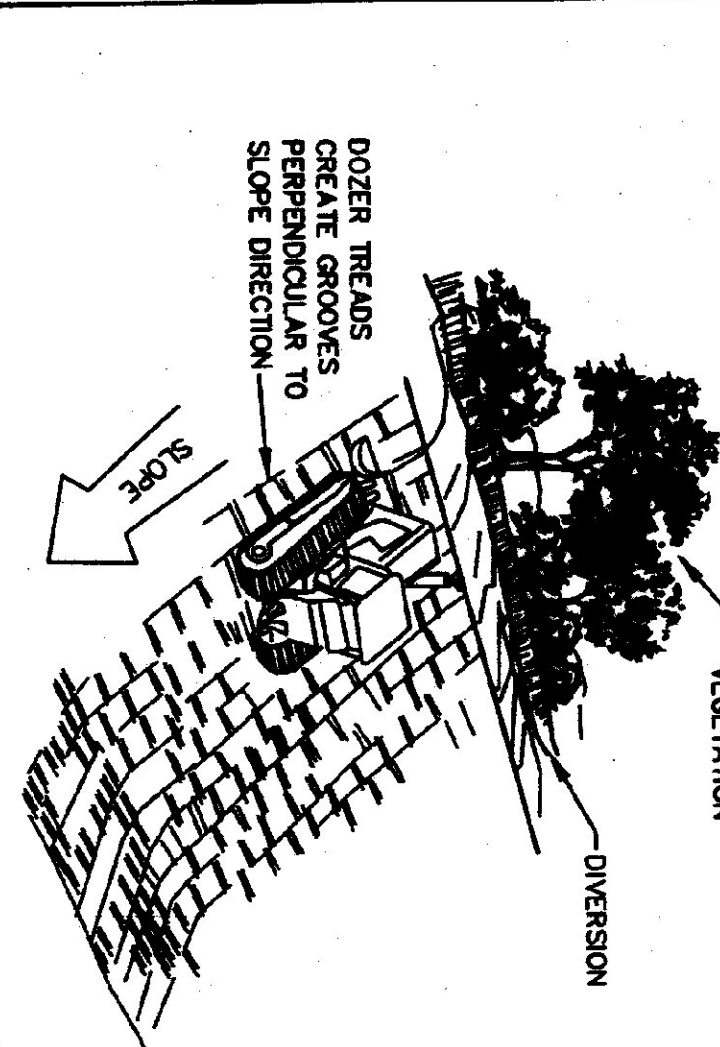

LEBS PER ACRE

SINCEGRASS (BLANKET OR SPLETTER)	4.0
LITTLE BLUESTEM (CLUMPS OR BLAZ)	2.0
SAND LIVERGRASS (VE-27 OR BLAZ)	1.5
BROODTOP REED (WAKO)	2.0

NOODLUM SPECIFIC TO BROODTOP REED MUST BE USED WITH THIS MIXTURE. IF SEEDING BY HAND, A STOCKING AGENT SUCH AS WAX OR HYDROPHOBIC AGENT SHOULD BE USED TO PREVENT THE SEED FROM HYDROPHOBIC AGENT. (4) TIMES THE RECOMMENDED AMOUNT OF NOODLUM.

PERMANENT SEED MIXTURE (REFER TO LANDSCAPE SPECIFICATIONS)

LEBS PER ACRE

SINCEGRASS (BLANKET OR SPLETTER)	4.0
LITTLE BLUESTEM (CLUMPS OR BLAZ)	2.0
SAND LIVERGRASS (VE-27 OR BLAZ)	1.5
BROODTOP REED (WAKO)	2.0

NOODLUM SPECIFIC TO BROODTOP REED MUST BE USED WITH THIS MIXTURE. IF SEEDING BY HAND, A STOCKING AGENT SUCH AS WAX OR HYDROPHOBIC AGENT SHOULD BE USED TO PREVENT THE SEED FROM HYDROPHOBIC AGENT. (4) TIMES THE RECOMMENDED AMOUNT OF NOODLUM.

PERMANENT SEED MIXTURE (REFER TO LANDSCAPE SPECIFICATIONS)

LEBS PER ACRE

SINCEGRASS (BLANKET OR SPLETTER)	4.0
LITTLE BLUESTEM (CLUMPS OR BLAZ)	2.0
SAND LIVERGRASS (VE-27 OR BLAZ)	1.5
BROODTOP REED (WAKO)	2.0

NOODLUM SPECIFIC TO BROODTOP REED MUST BE USED WITH THIS MIXTURE. IF SEEDING BY HAND, A STOCKING AGENT SUCH AS WAX OR HYDROPHOBIC AGENT SHOULD BE USED TO PREVENT THE SEED FROM HYDROPHOBIC AGENT. (4) TIMES THE RECOMMENDED AMOUNT OF NOODLUM.

PERMANENT SEED MIXTURE (REFER TO LANDSCAPE SPECIFICATIONS)

LEBS PER ACRE

SINCEGRASS (BLANKET OR SPLETTER)	4.0
LITTLE BLUESTEM (CLUMPS OR BLAZ)	2.0
SAND LIVERGRASS (VE-27 OR BLAZ)	1.5
BROODTOP REED (WAKO)	2.0

NOODLUM SPECIFIC TO BROODTOP REED MUST BE USED WITH THIS MIXTURE. IF SEEDING BY HAND, A STOCKING AGENT SUCH AS WAX OR HYDROPHOBIC AGENT SHOULD BE USED TO PREVENT THE SEED FROM HYDROPHOBIC AGENT. (4) TIMES THE RECOMMENDED AMOUNT OF NOODLUM.

PERMANENT SEED MIXTURE (REFER TO LANDSCAPE SPECIFICATIONS)

LEBS PER ACRE

SINCEGRASS (BLANKET OR SPLETTER)	4.0
LITTLE BLUESTEM (CLUMPS OR BLAZ)	2.0
SAND LIVERGRASS (VE-27 OR BLAZ)	1.5
BROODTOP REED (WAKO)	2.0

NOODLUM SPECIFIC TO BROODTOP REED MUST BE USED WITH THIS MIXTURE. IF SEEDING BY HAND, A STOCKING AGENT SUCH AS WAX OR HYDROPHOBIC AGENT SHOULD BE USED TO PREVENT THE SEED FROM HYDROPHOBIC AGENT. (4) TIMES THE RECOMMENDED AMOUNT OF NOODLUM.

PERMANENT SEED MIXTURE (REFER TO LANDSCAPE SPECIFICATIONS)

LEBS PER ACRE

SINCEGRASS (BLANKET OR SPLETTER)	4.0
LITTLE BLUESTEM (CLUMPS OR BLAZ)	2.0
SAND LIVERGRASS (VE-27 OR BLAZ)	1.5
BROODTOP REED (WAKO)	2.0

NOODLUM SPECIFIC TO BROODTOP REED MUST BE USED WITH THIS MIXTURE. IF SEEDING BY HAND, A STOCKING AGENT SUCH AS WAX OR HYDROPHOBIC AGENT SHOULD BE USED TO PREVENT THE SEED FROM HYDROPHOBIC AGENT. (4) TIMES THE RECOMMENDED AMOUNT OF NOODLUM.

PERMANENT SEED MIXTURE (REFER TO LANDSCAPE SPECIFICATIONS)

BID DOCUMENTS
DO NOT REVISE
January 24, 2002

1-24-02

1 REVISED PER VTRAMS COMMENTS 1/24/2002

READSPORO HIGHWAY GARAGE PROJECT

DEADWOOD, VERMONT

SITE DETAILS

0000 PROJECT NUMBER

25 OCTOBER 2001 DRAWING DATE

C8

DH
Dufresne-Henry
North Springfield, Vermont
Tel: 802.251.1001 • Fax: 802.251.2200
www.dufresnehenry.com

The Design Studio
Landscape Architecture
14 Cambridge Way, Vermont 05306 USA
Tel: 802.251.1001 • Fax: 802.251.2200
www.dufresnehenry.com

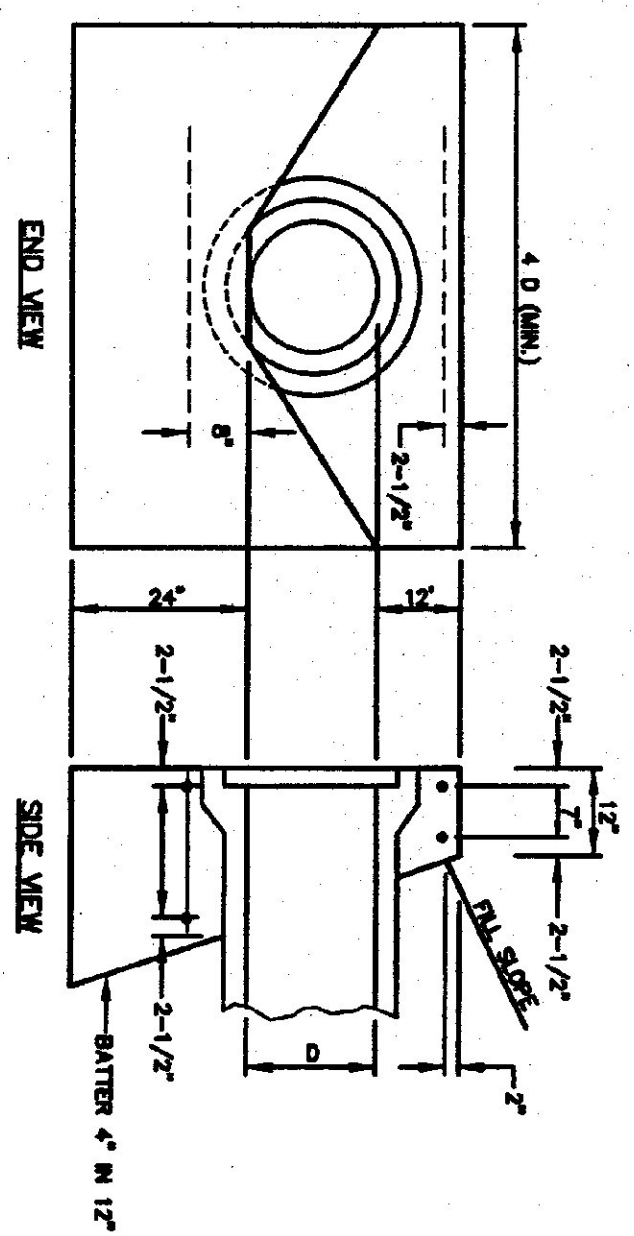

QUANTITY SCHEDULE FOR REINFORCED CONCRETE HEADWALL, CLASS B

PIPE DIAMETER	12"	15"	18"	24"	30"	36"	42"	48"	54"	60"
CONCRETE QUANTITY	1.0	1.3	1.8	2.7	3.5	4.9	6.4	8.0	10.0	12.3

STEEL SCHEDULE FOR REINFORCED CONCRETE HEADWALL

PIPE DIAMETER	12"	15"	18"	24"	30"	36"	42"	48"	54"	60"
NUMBER	4	4	4	4	4	4	4	4	4	4
LENGTH OF BARS	5'-0"	5'-0"	5'-0"	4'-0"	4'-0"	5'-0"	5'-0"	6'-0"	6'-0"	6'-0"

ALL REINFORCING STEEL TO BE #4 DIAMETER DEFORMED BARS. BARS TO BE PLACED IN 12" SPACING. BARS TO BE LAPPED WITH 48" OVERLAP. BARS TO BE LAPPED WITH 48" OVERLAP. BARS TO BE LAPPED WITH 48" OVERLAP.

REINFORCED CONCRETE HEADWALL DETAIL 1
NOT TO SCALE

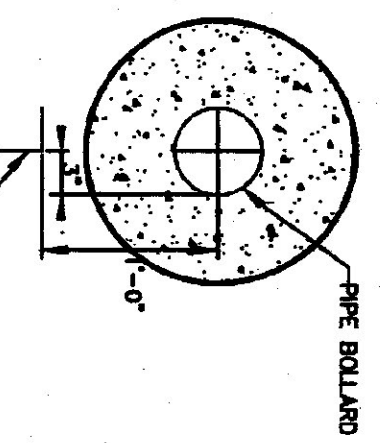

PLAN AT OVERHEAD DOOR JAMBS 2
NOT TO SCALE

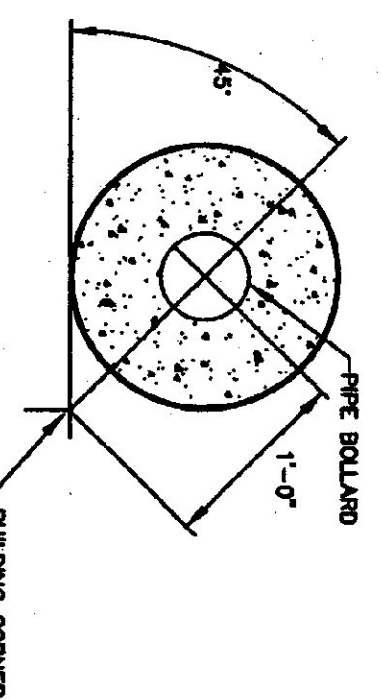

PLAN AT BUILDING CORNER 3
NOT TO SCALE

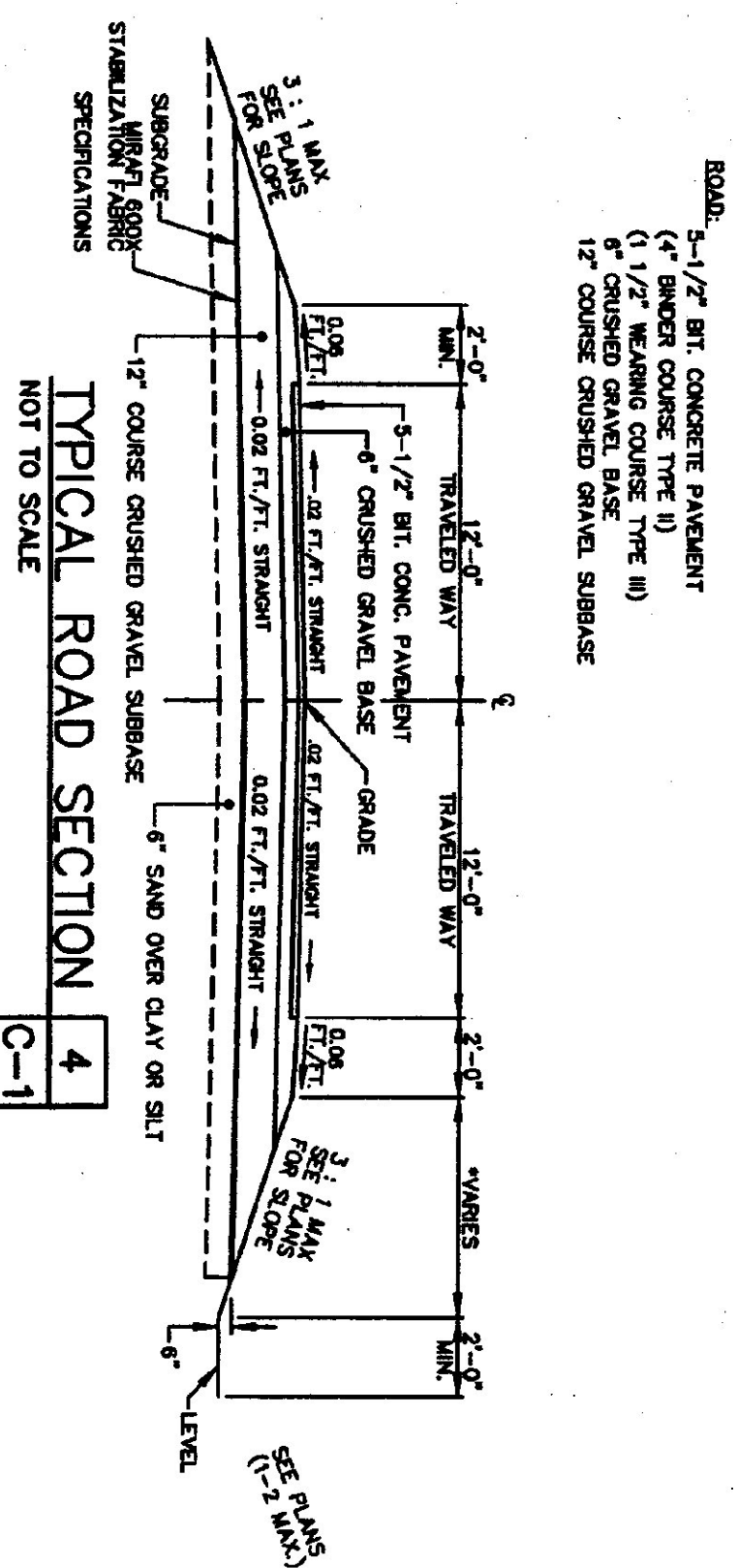

INSTALL PER MANUFACTURERS SPECIFICATIONS

TYPICAL ROAD SECTION 4
NOT TO SCALE

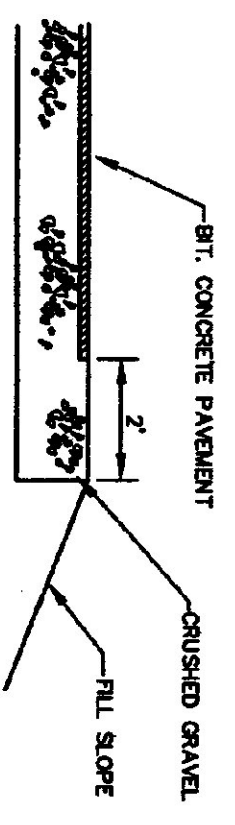

TYPICAL PAVEMENT EDGE DETAIL 5
NOT TO SCALE

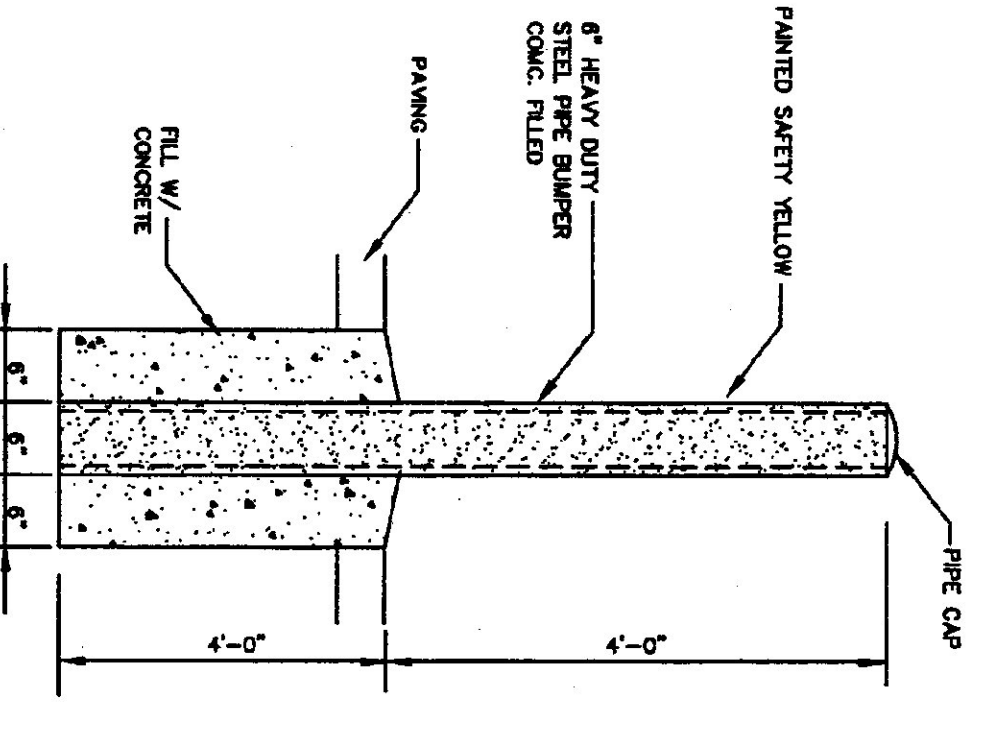

PIPE BOLLARD DETAIL 6
NOT TO SCALE

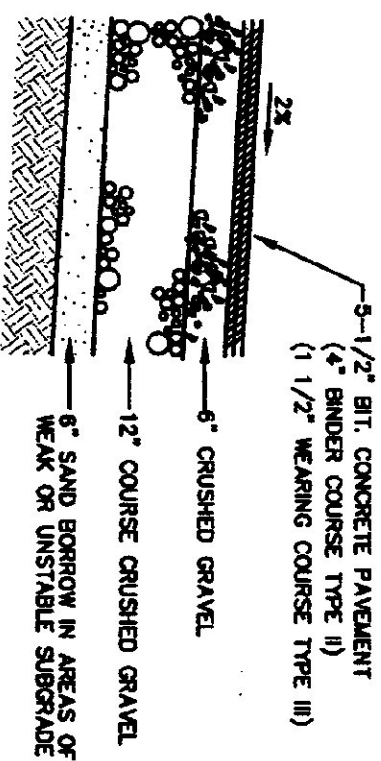

TYPICAL PAVEMENT SECTION 7
NOT TO SCALE

NOTE: MATERIALS TO COMPLY WITH WHAT STANDARD SPECIFICATIONS FOR CONSTRUCTION.

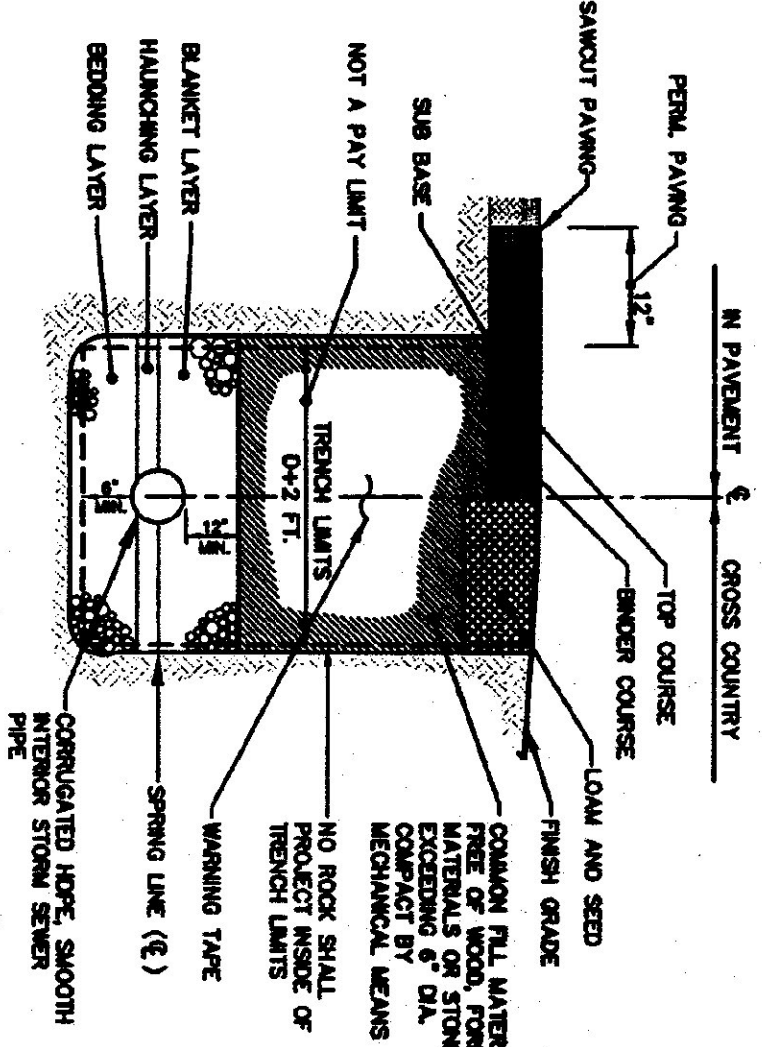

STORM SEWER TRENCH DETAIL 8
NOT TO SCALE

- NOTES:
- TYPE OF MATERIAL IN BEDDING, HAUNCHING AND BLANKET LAYERS TO BE CRUSHED GRAVEL.
 - WHEN PLACING HAUNCHING LAYER, USE SHOVEL TO FORCE MATERIAL INTO SPACES BETWEEN TRENCH LAYERS WHEN COMPACT AS REQUIRED.

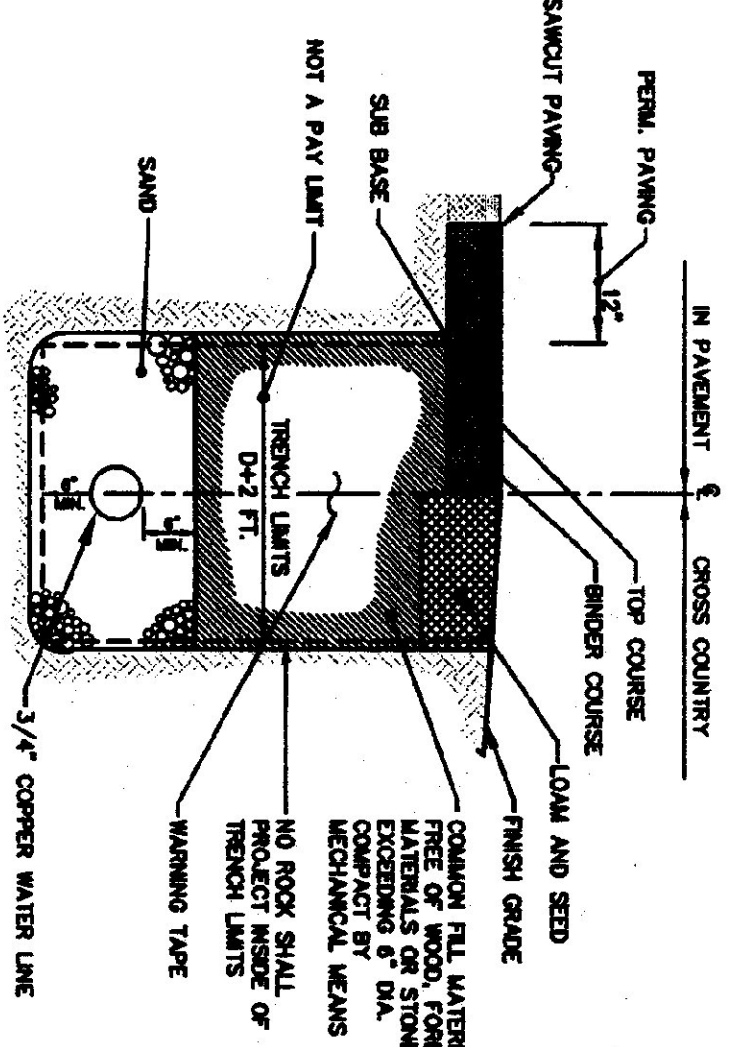

WATER LINE SERVICE TRENCH DETAIL 9
NOT TO SCALE

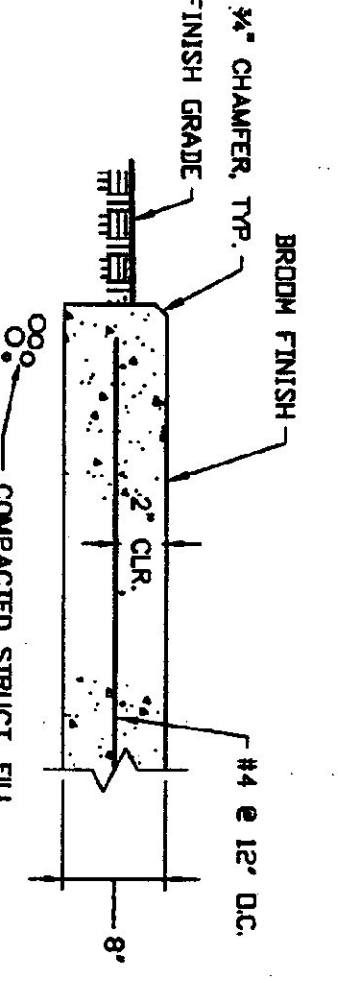

CONCRETE GENERATOR PAD ON GROUND 10
NOT TO SCALE

Project Architect
LineSonic Architecture
1000 N. 10th Street
Portland, ME 04108
Tel: (603) 876-1133
www.line-sonic.com

DH
Dufforne-Henry
North Springfield, Vermont
Tel: (802) 885-2261 • Fax: (802) 885-2260
www.dufforne-henry.com

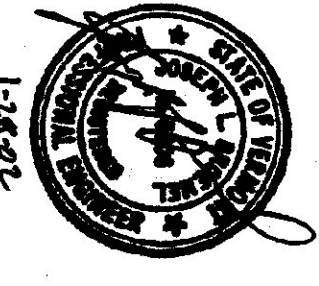

BID DOCUMENTS
DO NOT REVISE
January 24, 2002

NO.	REVISION PER VTRMANS COMMENTS	DATE
1	REMOVED PER VTRMANS COMMENTS	1/24/2002

READSBORO VERMONT
READSBORO
HIGHWAY
GARAGE PROJECT

SITE DETAILS

0000 PROJECT NUMBER
25 OCTOBER 2001 DRAWING DATE
C9 SHEET NUMBER

PERC TEST DATA:
 PERC 1: 7.26 MIN/IN
 PERC 2: 28.47 MIN/IN
 PERC 3: 13.00 MIN/IN
 PERC 4: 1.88 MIN/IN
 PERC 5: 5.10 MIN/IN
 PERC 6: 51.23 MIN/IN

TEST PIT DATA:

Test pits logged 08/14/01 by Bruce Cox.

Test Pit 1

0'-12"	Topsoil Dry
12'-30"	Medium grey brown till
30'-6"	Medium grey brown till with abundant weathered rock.

No refusal to depth
 No seepage observed
 Faint, light-brown orange mottles at 30"

Test Pit 2

0'-17"	Topsoil Dry
17'-8"	Medium grey brown till.

No refusal to depth
 No seepage observed
 Moderately prominent, discontinuous, light-medium orange mottles 26'-64"

Test Pit 3

0'-16"	Topsoil Dry
16'-9"	Medium grey brown till

No refusal to depth
 No seepage observed
 Faint, discontinuous, medium, brown, orange mottles at 36"

Test Pit 4

0'-15"	Topsoil Dry
15'-5"	Medium grey brown till
5'-8"	Till as above, but gravel

No refusal to depth
 No seepage observed
 Trace of mottles

Test Pit 5

0'-13"	Topsoil Dry
13'-4"	Medium grey brown till
4'-9"	Till as above, but gravel

No refusal to depth
 No seepage observed
 Faint, discontinuous, light-medium brown orange mottles below 30"

Test Pit 6

0'-12"	Topsoil Dry
12'-4"	Medium grey brown till
4'-8"	Till as above, but gravel

No refusal to depth
 No seepage at 34"
 Prominent, continuous, light-medium orange mottles at 24"

MOUND SAND SIEVE ANALYSES:

TYPE	SIEVE NUMBER	OPENINGS (MM)	PERCENT PASSING BY WEIGHT
TYPE A:	10	2,000	85-100
	60	0,420	25-75
	100	0,440	0-50
	200	0,075	0-5
	4	4,750	95-100
TYPE B:	8	2,380	80-100
	16	1,190	50-85
	30	0,590	25-60
	50	0,297	10-30
	100	0,149	2-10
TYPE C:	10	2,000	85-100
	40	0,420	30-50
	200	0,075	0-10

Septic Tank to Leaching Area CONSTRUCTION NOTES:

1. Cut and remove all above-ground vegetation in the area of proposed mound. Cut any tree stumps flush with the ground and leave the roots in place.
2. Plow the area parallel to the contour of the land to a depth of 7-8 inches, throwing the soil windward. Construction equipment should be used to level the surface after the plowing is complete. Prior to placing any fill for the mound, the plow surface shall be inspected and approved by the Engineer.
3. Place the sand fill over the area per plan, (minimum depth of 21 inches) above the plowed surface. The Engineer shall approve the sand fill prior to installation.
4. Excavate the bed and place 9 inches of crushed stone in the trenches. Hand level the stone and temporarily install the distribution pipe without giving the joints, with the perforations placed facing upward for testing. Cap the ends of the pipe as shown in the detail on this sheet.
5. Test the network with clean water to assure equal distribution through the pipes. The difference in discharge between any two perforations shall not be greater than 15%. This testing shall be conducted in the presence of the Engineer. Upon successful testing move the pipe joints and end caps so the perforations are facing downward.
6. Place 2" crushed stone over the distribution pipe. Cover the crushed stone with a layer of filter fabric (Mirofil 140N).
7. Cover the entire mound with soil less permeable than the sand fill to a depth of 18 inches at the center and 12 inches on the side slopes. Seed and mulch the entire mound. A minimum of 4" of topsoil will be placed at the surface.
8. All work shall be performed in conformance with the Environmental Protection Rules 8/8/96, Vermont Agency of Environmental Conservation, including leakage testing of force mains.
9. Surface runoff from building and driveway area shall not be directed toward septic system.
10. "Crushed stone" used in the construction of leaching trenches shall be a clean and durable stone, and be no larger than 1 1/2 inches in diameter or larger than one and one-half inches in diameter, as per (Environmental Protection Rules 1-703).
11. The septic tanks and distribution boxes shall be precast units as supplied by W.E. Daley, Inc. to be installed in accordance with the plans and modified structurally as needed for earth cover, water table conditions and septic cover modifications.
12. When manholes or inspection covers with risers constructed to grade are constructed the ground surface surrounding the manholes shall be sloped to insure drainage away from the manhole.
13. The septic tank shall have a filter constructed on the outlet pipe. Filter shall be a 4" biotube effluent filter, model FT-0418-4, by Omeco System Inc.

DESIGN CRITERIA FOR WASTEWATER DISPOSAL

1. DESCRIPTION
 - a) FLOWS TO THE SEPTIC SYSTEM WILL COME FROM DOMESTIC USE BY EMPLOYEES.
2. AVERAGE FLOWS
 - 5 EMPLOYEES AT 15GPD EACH = 75 GPD
3. SEPTIC TANK REQUIREMENTS
 - USE 1000 GALLON HEAVY DUTY 10'x7' SEPTIC TANK BY W.E. DALEY, INC. WITH ACCESS COVER OPENINGS FOR 4" DIAMETER RISER
4. LEACHING AREA
 - a) DESIGN PERC RATE = 28.47 MIN/IN.
 - b) APPLICATION RATE = 0.74gal/sf/day
 - c) APPLICATION RATE = 101 s.f. REQUIRED
 - d) APPLICATION AREA REQUIRED
 - e) TRENCH LENGTH = 28
 - f) TRENCH WIDTH = 4
 - g) STONE DEPTH BELOW PIPE = 9"
 - h) LEACHING AREA PROVIDED = 1 TRENCH, 4' WIDE, 28' LONG = 104 SF (BOTTOM AREA)

PUMP STATION DETAIL

11
C-1

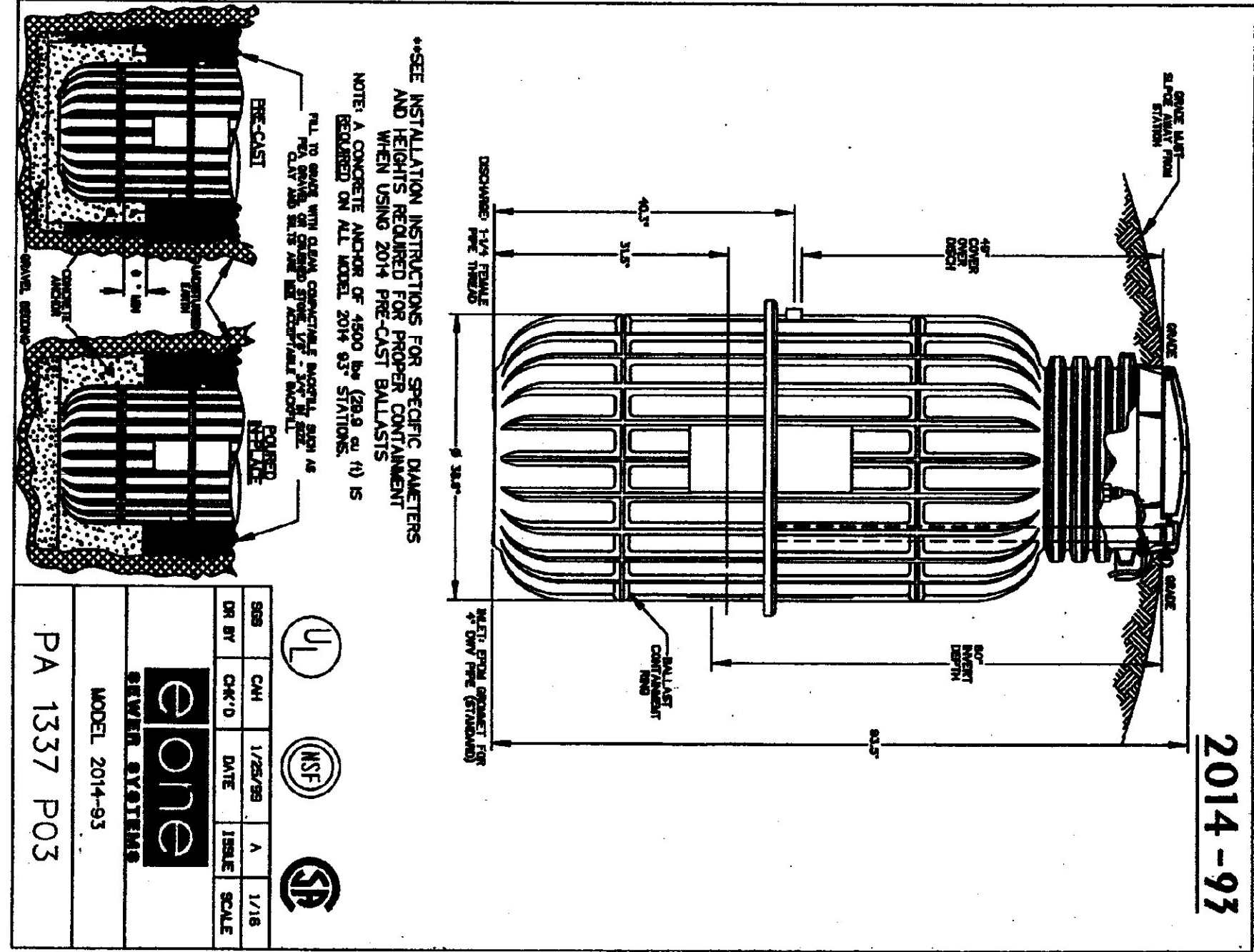
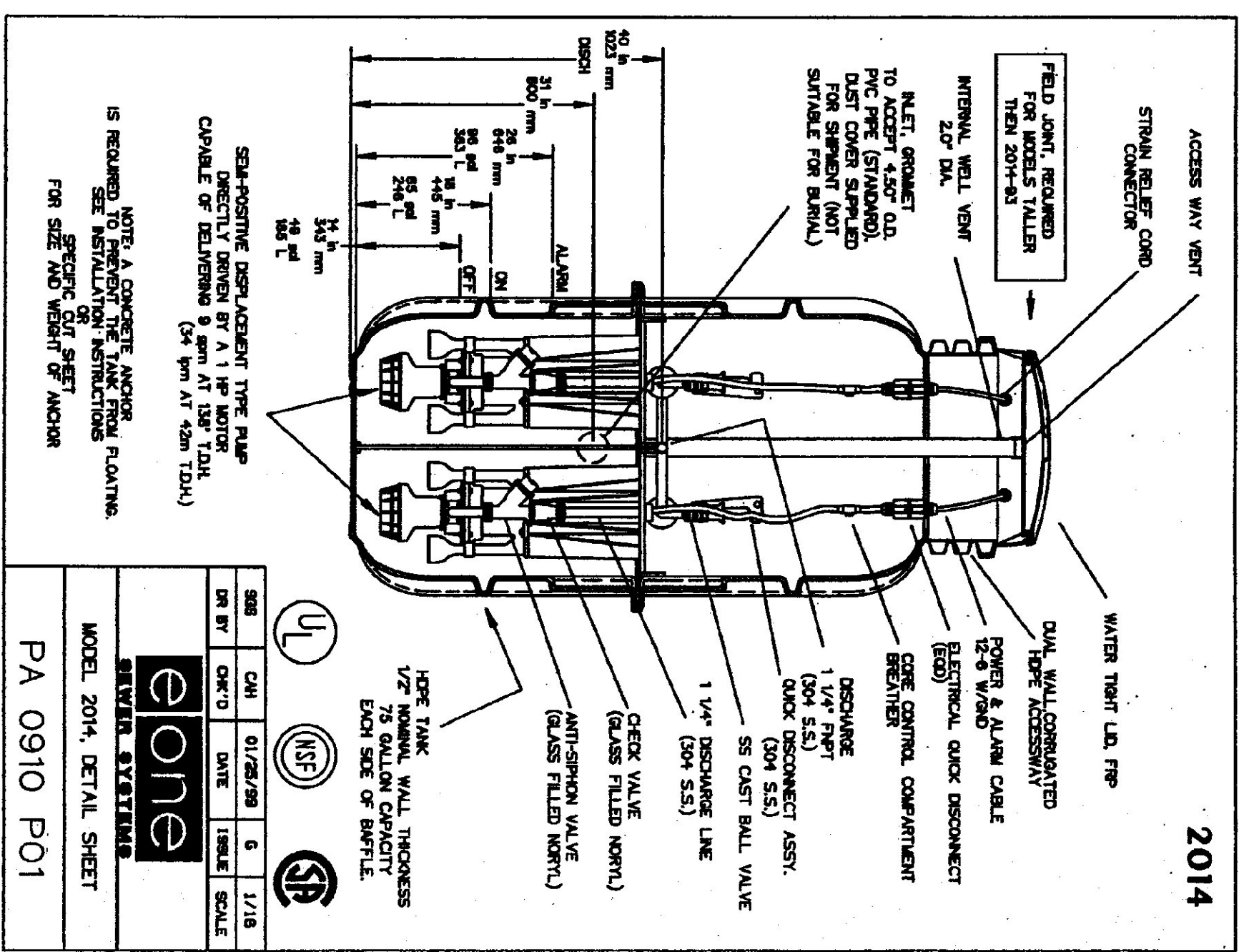

The Design Studio of
LineSync Architecture
 1406 Hill Village Vermont 05696 USA
 TEL: 802/251-1232 FAX: 802/251-1232
 WWW: Linesync.com

DH
 Dufresne-Henry
 74 North Springfield Vermont 05602
 TEL: 802/251-1232 FAX: 802/251-1232
 WWW: dufresnehenry.com



BID DOCUMENTS
 DO NOT REVISE
 January 24, 2002

NO.	REVISION PER VISUAL COMMENTS	DATE
1	REVISED PER VISUAL COMMENTS	1/24/2002

READSBORO
 HIGHWAY
 GARAGE PROJECT
 READSBORO, VERMONT

SEPTIC SYSTEM DETAILS
 SHEET TITLE

PROJECT NUMBER: 0000
 DATE: 25 OCTOBER 2001
 DRAWING DATE: 25 OCTOBER 2001
C10

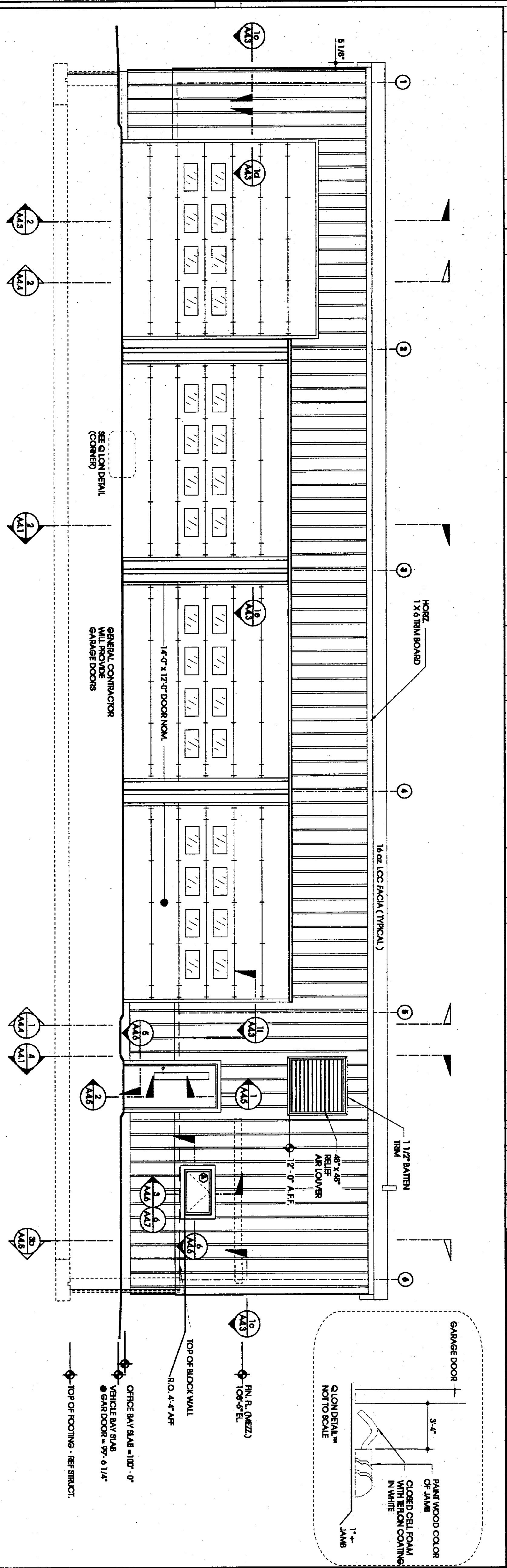

1 FRONT ENTRY SOUTH ELEVATION

1/4" = 12"
AS 1

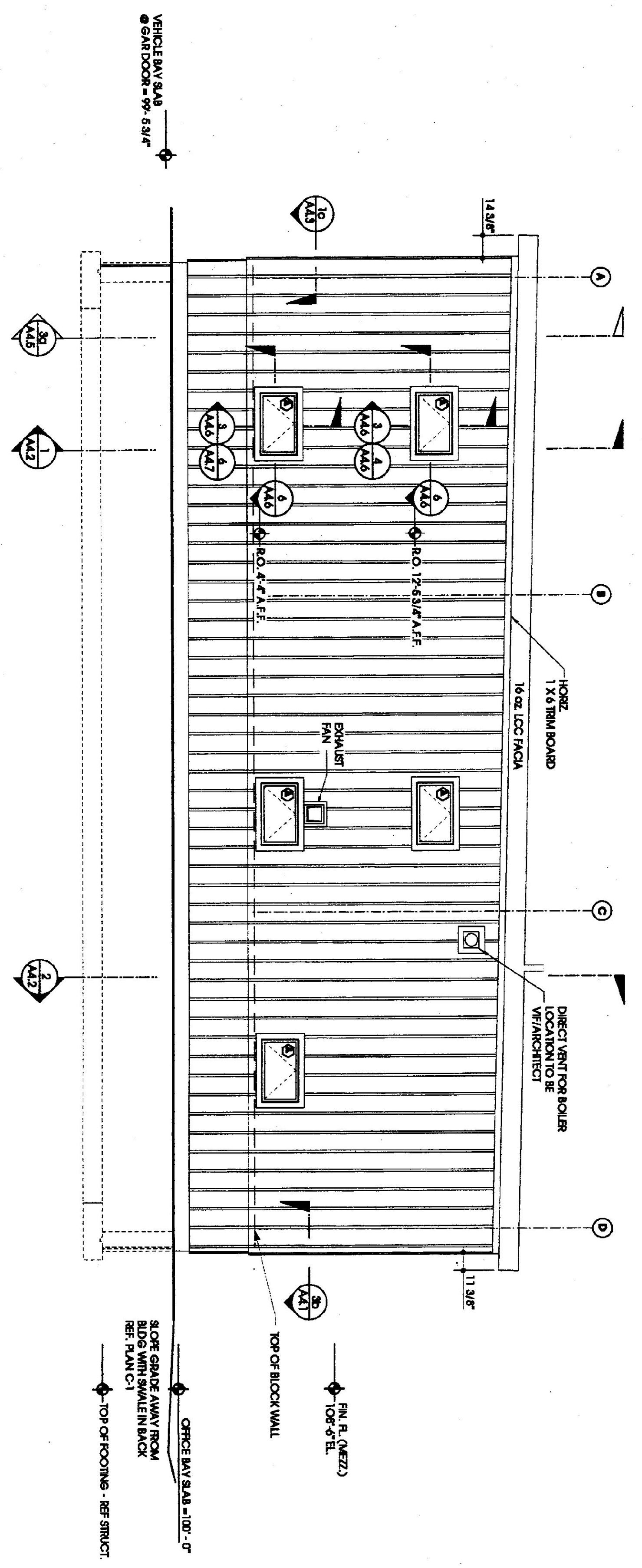

2 EAST SIDE ELEVATION

1/4" = 12"
AS 1

REGISTERED ARCHITECT
STATE OF VERMONT
NO. 1100
VERMONT ARCHITECTS ASSOCIATION

The Design Studio of
LineSync Architects
14 College Hill Way
North Ferrisburgh, Vermont 05654-9746 USA
Vermont License No. 17-2308
www.linesync.com

DATE: _____

- STATE HIGHWAY GARAGE GENERAL NOTES**
1. PROJECT TO CONFORM TO REG. 1000 WITH THE NATIONAL BUILDING CODE WITH ALL THE LOCAL AND STATE REQUIREMENTS AND THE LOCAL AND STATE REQUIREMENTS FOR THE BUILDING. THE CONTRACTOR SHALL BE RESPONSIBLE FOR OBTAINING ALL NECESSARY PERMITS AND APPROVALS FROM THE LOCAL AND STATE AUTHORITIES.
 2. THE CONTRACTOR SHALL VERIFY CONDITIONS AND DIMENSIONS IN FIELD PRIOR TO CONSTRUCTION.
 3. ALL BRACING IN CONTACT WITH CONCRETE AND MASONRY TO BE PRESERVED THROUGHOUT.
 4. COORDINATE ALL IRON WORK WITH PROJECT MANUAL.
 5. ARCHITECTURAL ELEVATION SHALL BE REFERENCED TO THE TOP OF THE GARAGE SLAB. THE FINISH FLOOR ELEVATION SHALL BE REFERENCED TO 54'-0" DEP. C-1.

PROJECT DRAWING LIST

- C1 CIVIL BY NUMBER/REVISION
 - C2 INTERIOR PLAN
 - C3 ROAD PROFILE
 - CA 5.67 ROAD CROSS SECTIONS
 - CA 9 RETICULAR DETAILS
 - CU 11. RETIC SYSTEM DETAILS
- GARAGE & OFFICE BY NUMBER/REVISION
- A11 INTERIOR LAYOUT PLAN & REVISIONS
 - A22 ELEVATIONS
 - A31 1ST FL. PLAN
 - A32 MEZZANINE/ROOF PLAN WINDOW/DOOR SCHEDULE
 - A41 INTERIOR ELEVATIONS & SECTIONS
 - A42 WALL SECTIONS & DETAILS
 - A43 WALL SECTIONS & DETAILS
 - A44 WALL SECTIONS & DETAILS
 - A45 WALL SECTIONS & DETAILS
 - A46 DETAILS
 - A47 WINDOW & STAIR DETAILS

- GARAGE STRUCTURAL BY B.A.L.A.M. ASSOCIATES
- S01 GEN STRUCT NOTES & STANDARD DETAILS
 - S11 FOUNDATION PLAN
 - S12 ROOF FRAMING PLAN
 - S13 STRUCTURAL SECTIONS & DETAILS
 - S31 STANDARD STRUCTURAL DETAILS
- ELECTRICAL BY NUMBER/REVISION
- B01 ELECTRICAL INTERIOR
 - B1 FIRST FLOOR PLAN (INCLUDES MEZ.)

- GARAGE MECHANICAL BY NUMBER/REVISION
- M1 GARAGE MECHANICAL PLAN
 - M2 GARAGE MECHANICAL SECTIONS/DETAILS
 - B01 A/C UNIT 2400 BTU/HOUR
 - B02 A/C UNIT 2400 BTU/HOUR
 - P1 BRIND PLAN & DETAILS
 - V-1 VENTILATION SYSTEM PLAN & DETAILS

NO.	DATE	DESCRIPTION
1	20 NOV 01	ISSUED FOR STATE REVIEW
2	07 FEB 02	ISSUED FOR BID

ATSIF
AGENCY OF TRANSPORTATION
STORAGE FACILITY PROJECT

RELANDORNO, VERMONT

ELEVATIONS
FRONT & RIGHT SIDE

DATE: 17 JUNE 2001

PROJECT NUMBER: 0113

SCALE: 1/4" = 12"

A2.1

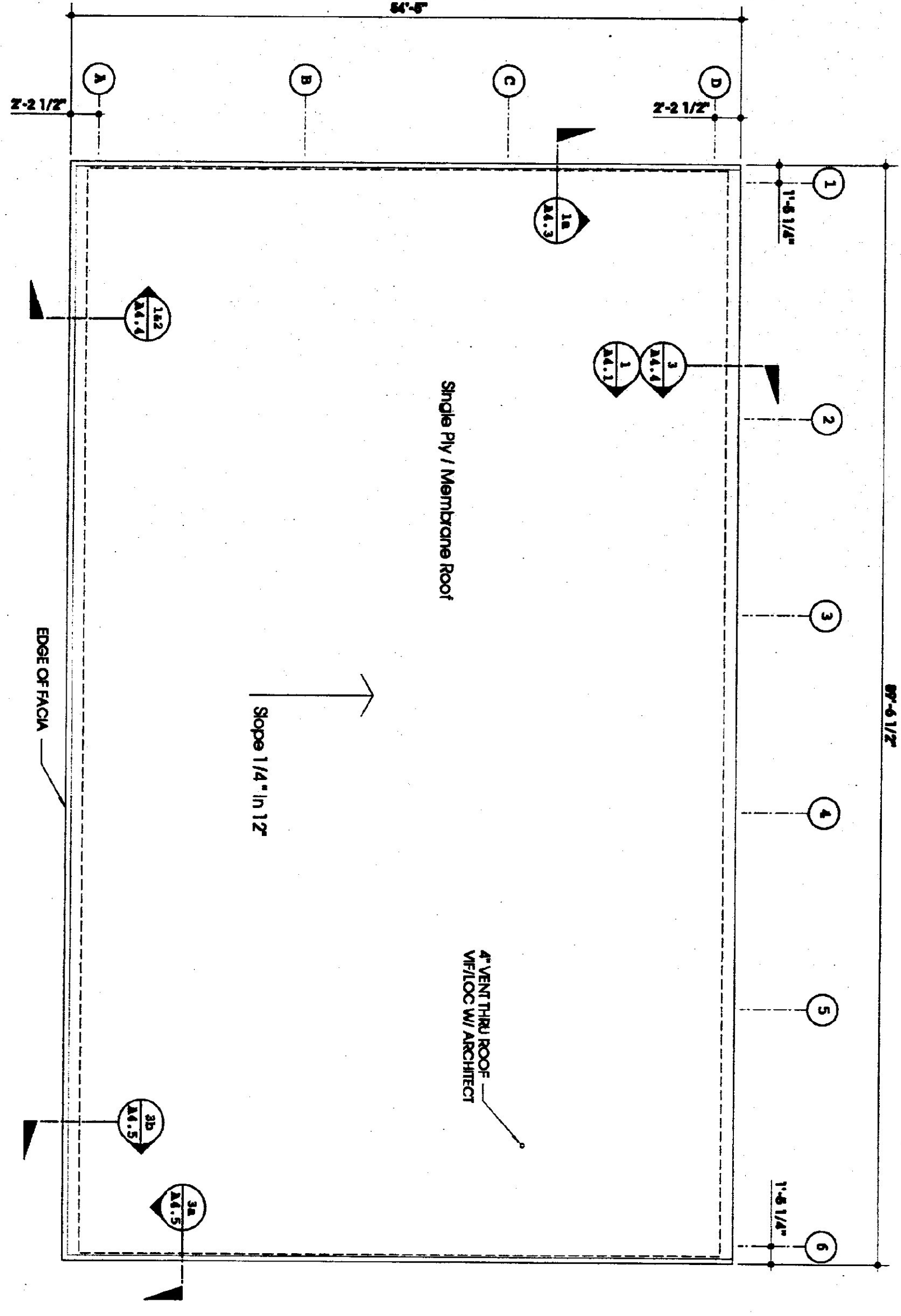

1 ROOF PLAN

NO.	QTY.	SIZE	TYPE	FRM. RAINING	DOOR MATERIAL	FRAME MATERIAL	HOW SET #	GLAZING REQUIRED	BUTTS	LOCK PLATE	WIRE STRIP	CLOSERS	REMARKS
D1,2	3	3'-0" x 7'-0"	I	C	INSULATED METAL	METAL	1	6" x 48" WIREGLASS	4 1/2" x 1 1/2" BALL BEARING NON-REMOVABLE PINS	3/4" x 10" STAINLESS STEEL	VINYL	SARGENT'S 1280 X P.A. X.H.O.	THERMAL BREAK FRAME, SWEEP
D4	1	3'-0" x 6'-8"	II	C	HOLLOW METAL	METAL	2	20" x 32" SAFETY	4 1/2" x 1 1/2"	-	NONE	SARGENT'S 1280 X H.O.	
D7	1	-	III	B	-	-	-	-	-	-	-	-	
D6	1	-	III	B	-	-	-	-	-	-	-	-	
D6	1	-	III	B	-	-	-	-	-	-	-	-	
D9	3	14 W. x 12 H.	IV	C	INSULATED STEEL	17" STEEL CHANNEL	4	-	-	-	-	-	ELECTRIC OVERHEAD DOOR SERIES 591
D11	1	14x14 NOM.	V	C	-	-	-	-	-	-	-	-	THERMACORE W/ACRYLIC WINDOWS

DOOR SCHEDULE

NO.	QTY.	TYPE	FRAME MATERIAL	ROUGH OPENING	REMARKS
A	10	AWNING	METAL	3'-4 1/2" W. x 2'-0 1/2" H.	HARVEST ALL VINYL WINDOWS ACTUAL SEE TO BE VENDOR

WINDOW SCHEDULE

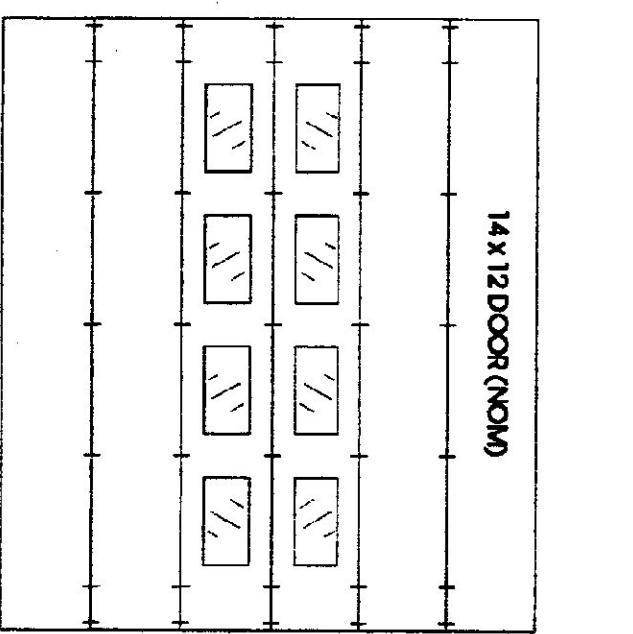
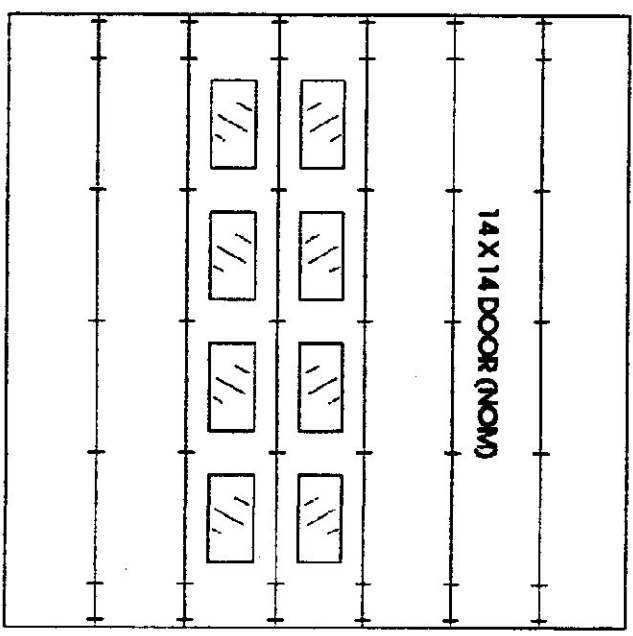
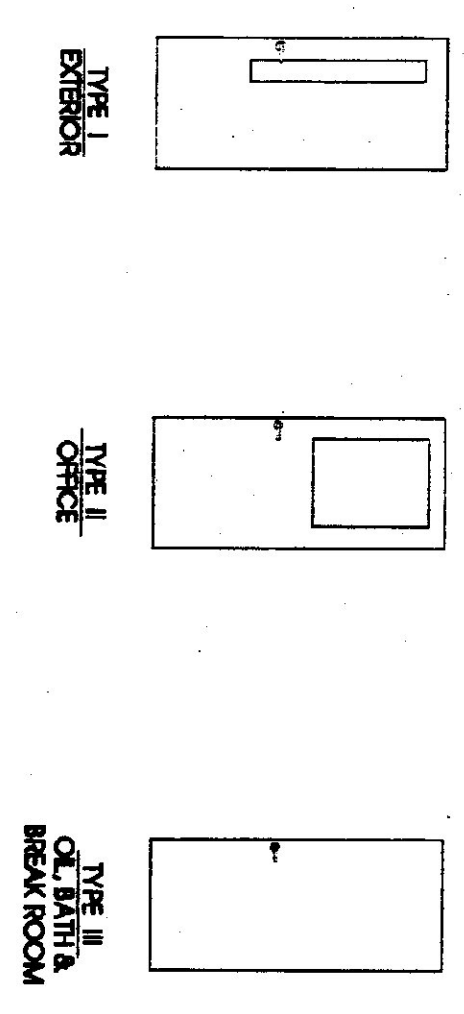

2 DOOR & WINDOW SCHEDULES

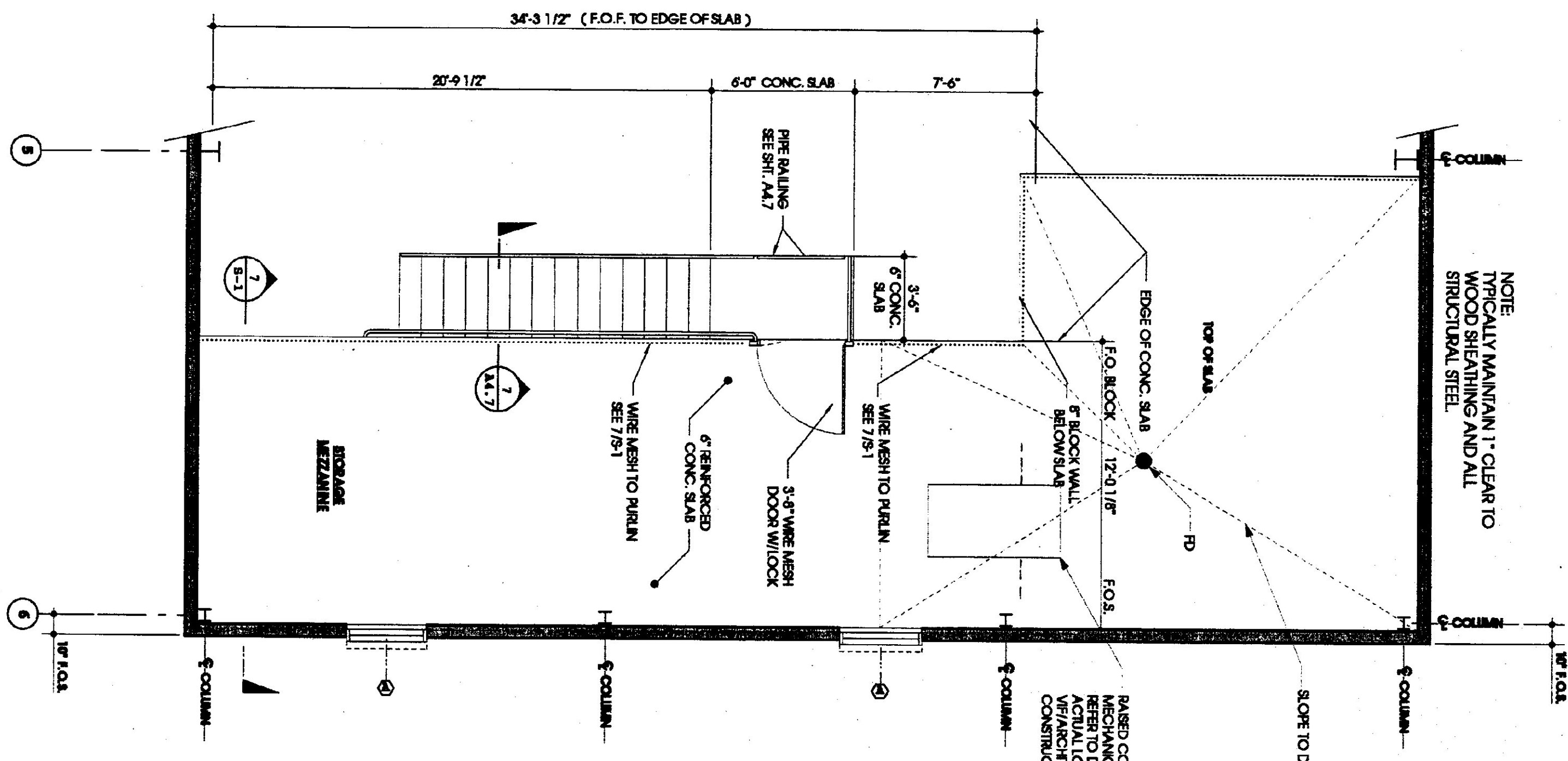

3 GARAGE STORAGE MEZZANINE PLAN

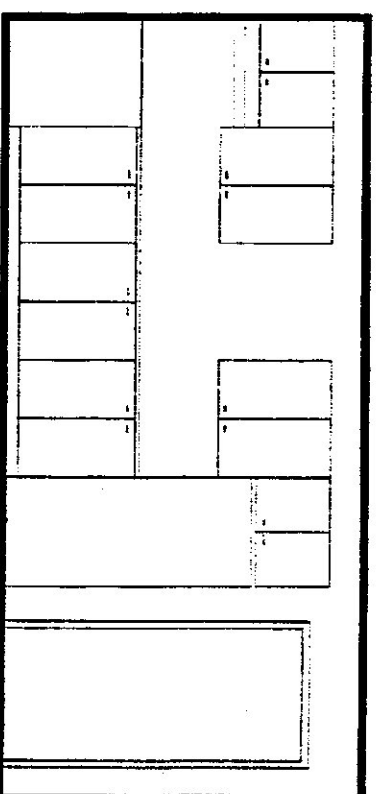

- KITCHEN CABINET SPECIFICATIONS:
1. DOORS TO USE 1/2" OVERLAY CABINET HINGES
 2. FINISH TO BE GREEN LAMINATE OVER MDF
 3. PULLS TO BE MFG BY HAVLE CANT # 11639213
 4. CHROME PLATED WHITE FINISH
 5. COUNTERTOP BY HARRISON (KEMENY); DIAMOND TOP; COLOR BLACK FOREST

4 BREAKROOM CABINET ELEVATION

The Design Studio of
Linesync Architecture
 14 Centre Hill Whittington Vermont 05848 9746 USA
 (802) 464-2826 / FAX 802
 www.Linesync.com

- SLATE HIGHWAY GARAGE GENERAL NOTES**
1. PROJECT TO CONFORM TO LOCAL LAW WITH THE NATIONAL ELECTRICAL CODE AND CODES ENACTED BY LOCAL AND STATE AUTHORITIES HAVING JURISDICTION SHALL APPLY TO THE ELECTRICAL BUSINESS (SIMILAR TO REGULATION).
 2. THE CONTRACTOR SHALL VERIFY CONDITIONS AND DIMENSIONS IN FIELD PRIOR TO RECEPTION.
 3. ALL FINISHES IN CONTACT WITH CONCRETE AND MASONRY TO BE FINISHED THROUGH ROOF.
 4. COORDINATE ALL DRAIN WINDS WITH PROJECT MANUAL.
 5. ARCHITECTURAL ELEVATION REFLECTS REFERENCE A 100% DATUM AT THE TOP OF THE OFFICE SLAB. THIS IS EQUIVALENT TO THE SITE ELEVATION ELEVATION OF 596.57 REF. C1.

- PROJECT DRAWING LIST**
- CIVIL BY DISPENSE-HENNEY
 - G1 SITE PLAN
 - G2 ROAD PROFILE
 - G3 ROAD CROSS SECTIONS
 - G3.9 SITE DETAILS
 - C10.11. SITE VERTICAL DETAILS
- GARAGE & OFFICES BY LINNSYNC ARCHITECTURE**
- A11 SITE PLAN, LOCATION MAP & REFERENCES
 - A21 ELEVATIONS
 - A22 ELEVATIONS
 - A31 I.P.F. PLAN
 - A32 MEZZANINE/ROOF PLAN, WINDOW, SCHED
 - A41 SECTION DETAILS
 - A42 INTERIOR ELEVATIONS & SECTIONS
 - A43 WALL SECTIONS
 - A44 WALL SECTIONS & DETAILS
 - A45 WINDOW & SLAB DETAILS
 - A46 DETAILS

ATSP AGENCY OF TRANSPORTATION STORAGE FACILITY PROJECT

REARBOARD, VERMONT

FLOOR PLAN

NOV 01 20 NOV 01 ISSUED FOR STATE REVIEW

07 FEB 02 ISSUED FOR BID

0113

17 JUNE 2001

DATE

17 JUNE 2001

DATE

A3.2

17 JUNE 2001

DATE

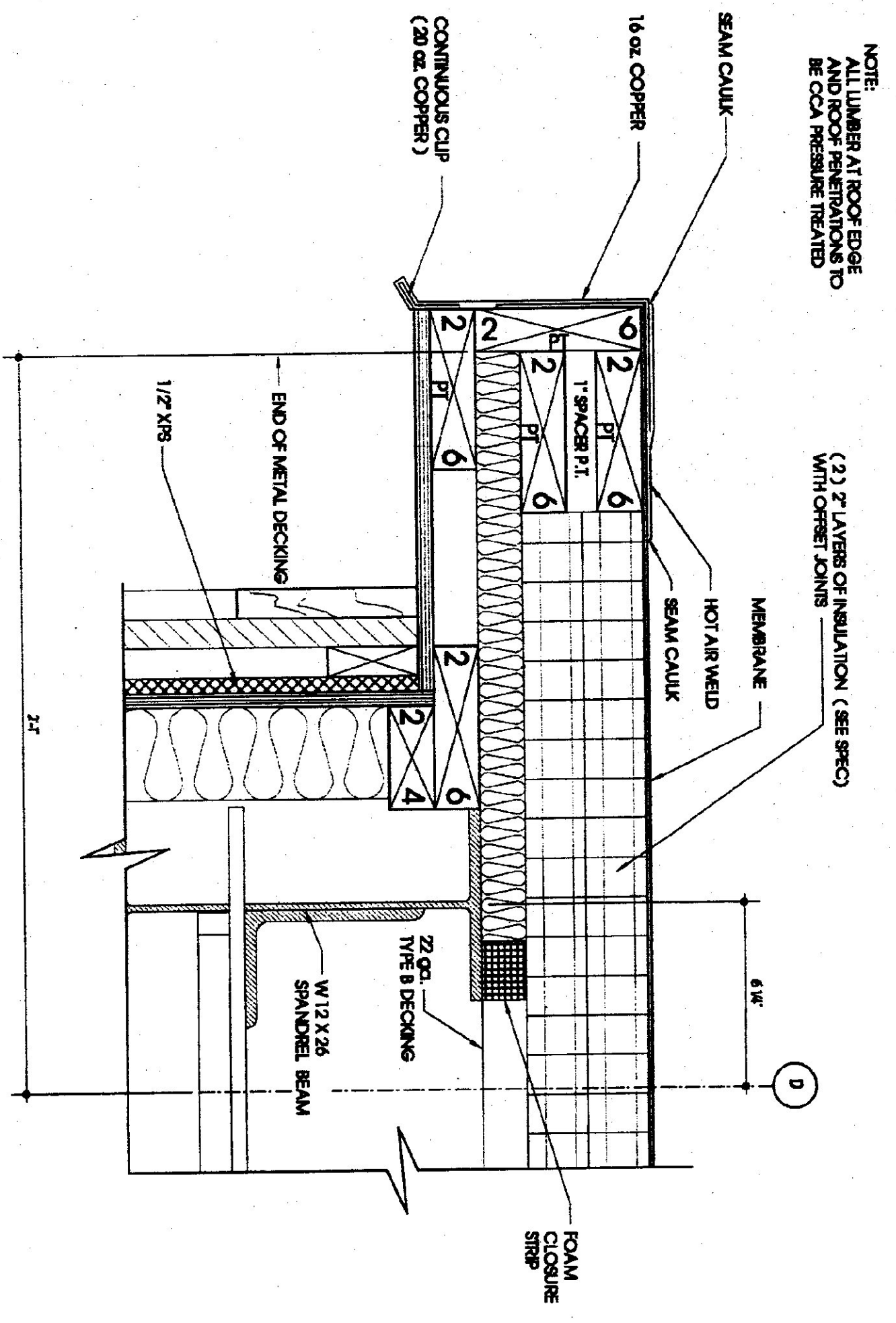

1 ROOF DRIP EDGE 3/4" = 1'-0" M.1

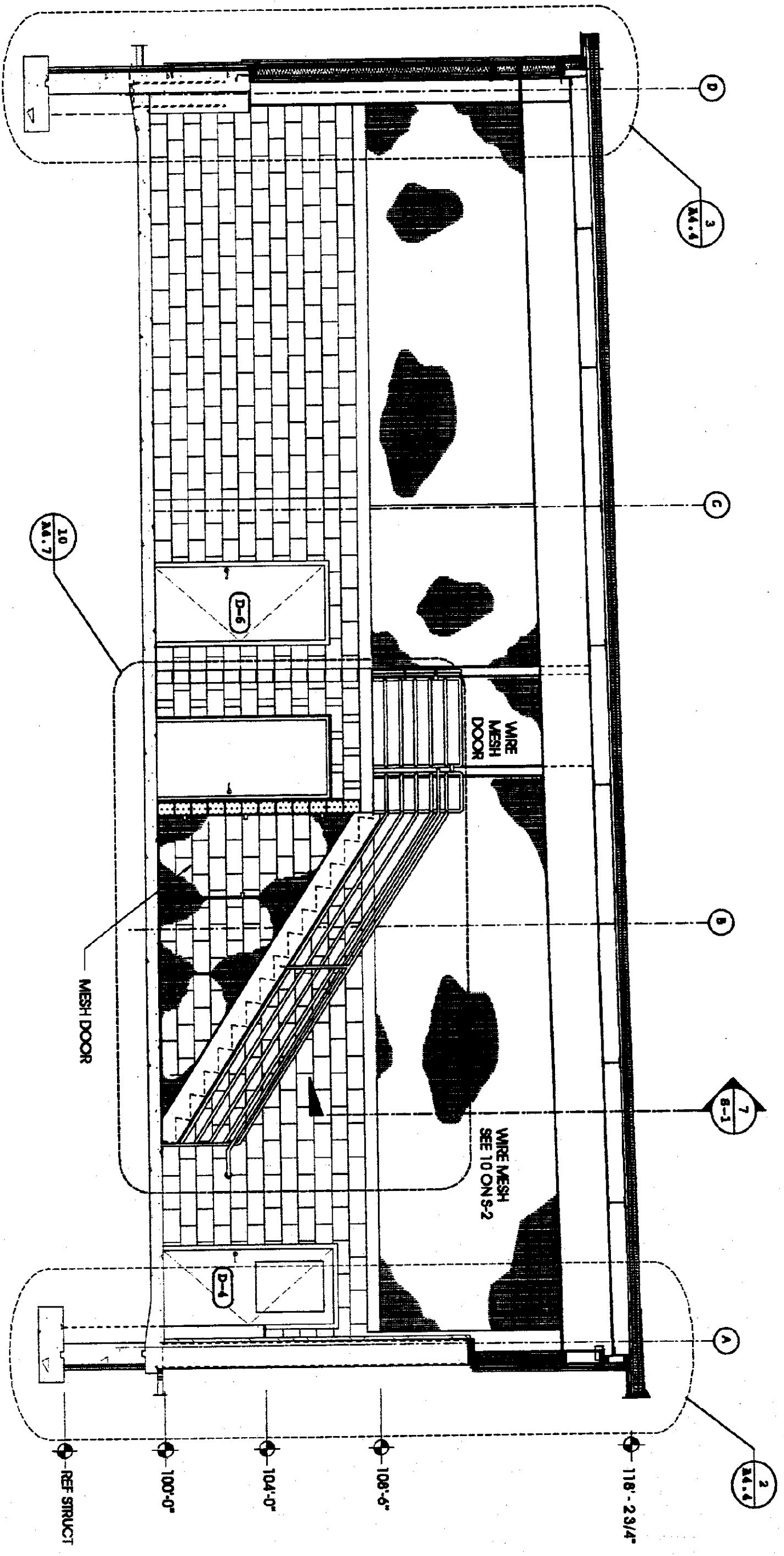

2 GARAGE SECTION 1/4" = 1'-0" A.21 A.41

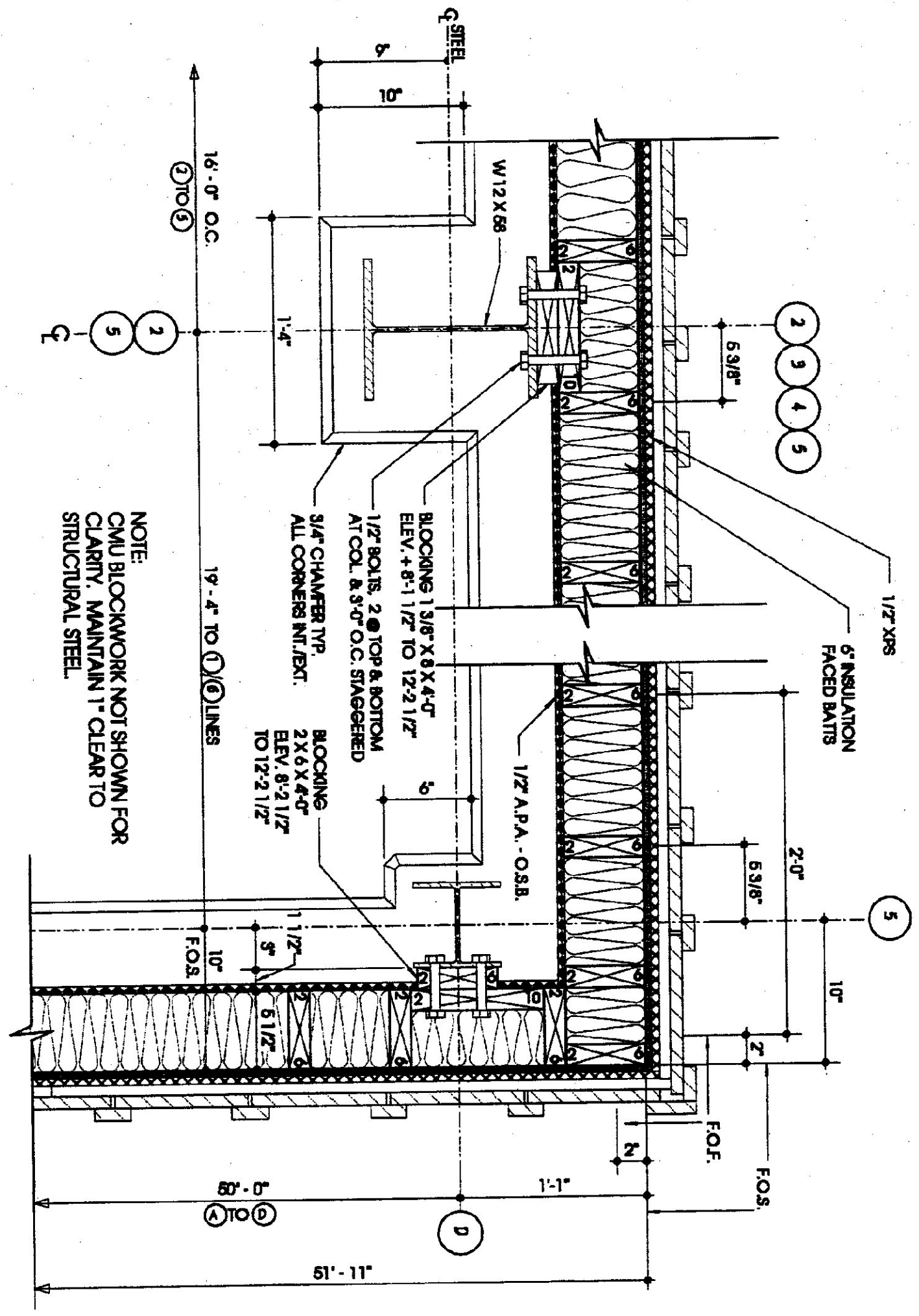

3 WALL PLAN DETAIL 1/4" = 1'-0" M.1

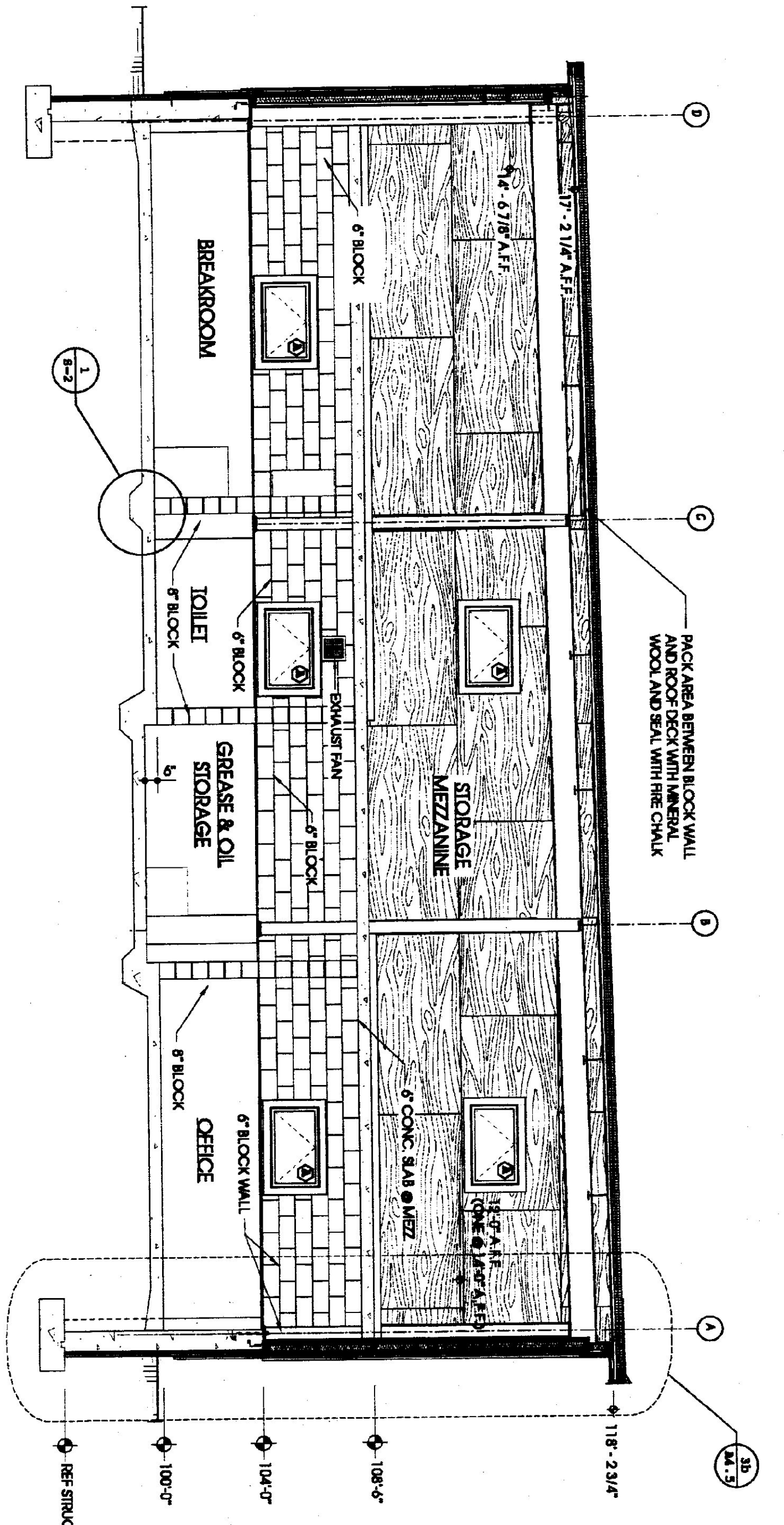

4 OFFICE AREA SECTION 1/4" = 1'-0" M.1

The Design Studio of
Linesync Architecture
 14 Corbin Hill Washington Vermont 05405 9745 USA
 V.802.244.2525 / T.24828
 www.Linesync.com

- STATE REVIEW AT GARAGE GENERAL NOTES**
1. PROJECT TO CONFORM TO LOCAL LAW WITH THE NATIONAL ELECTRICAL CODE. OTHER CODES SUCH AS THE INTERNATIONAL MECHANICAL AND PLUMBING CODES SHALL BE REFERENCED BY THE CONTRACTOR. THE CONTRACTOR SHALL BE RESPONSIBLE FOR OBTAINING ALL NECESSARY PERMITS AND APPROVALS FROM THE LOCAL BUILDING DEPARTMENT.
 2. THE CONTRACTOR SHALL VERIFY CONDITIONS AND DIMENSIONS IN FIELD PRIOR TO RECEPTION.
 3. ALL BRACING IN CONTACT WITH CONCRETE AND MASONRY TO BE PRESERVE TREATED WOOD.
 4. COORDINATE ALL BRACING WITH PROJECT MANUAL.
 5. ARCHITECTURAL ELEVATION BULLETIN REFERENCE A 100% DRAWING AT THE TOP OF THE SEVEN ELEVATION OF 24-07. REF. C.1.

- PROJECT DRAWING LIST**
- C111. W/ PROGRESSIVE-BENEFIT
 - C1. W/ INTERPLAN
 - C2. LAYOUT PLAN
 - C3. ROAD PROFILE
 - C4.567. ROAD CROSS SECTIONS
 - C8.9. RTTS DETAILS
 - C1111. SEPTIC SYSTEM DETAILS
- GARAGE & OFFICE BY LINENSINC ARCHITECTURE**
- A.21. ELEVATIONS
 - A.41. ELEVATIONS
 - A.31. INT. FLOOR PLAN
 - A.32. MEZZANINE/FLOOR PLAN, WINDOWWORK, KITCHEN
 - A.41. INTERIOR ELEVATIONS
 - A.43. INTERIOR ELEVATIONS & SECTIONS
 - A.44. WALL SECTIONS & DETAILS
 - A.45. DETAILS
 - A.46. WINDOW & FAIR DETAILS

- GARAGE STRUCTURAL BY BALKAN ASSOCIATES**
- B.11. GEN. STRUCT. NOTES & STANDARD DETAILS
 - B.11. FOUNDATION PLAN
 - B.12. STRUCTURAL SECTIONS & DETAILS
 - B.13. FINISHED STRUCTURAL DETAILS
- ELECTRICAL BY DUFFENBERG-BENNETT**
- B.1. ELECTRICAL SITE PLAN
 - B.1. FIRST FLOOR PLAN (ON CONCLUDES MEZ.)
- GARAGE MECHANICAL BY DEPT. OF STATE BLDG. MAINT.**
- M.1. OVERHEAD MECHANICAL SYSTEMS
 - B.1. A.O.T. 24-08 STORAGE BLDG. DETAIL
 - B.1. A.O.T. 24-08 BLDG. BAND SHEAR WALL DETAIL
 - P.1. PIPING PLANS & DETAILS
 - V.1. VENTILATION SYSTEM PLANS & DETAILS

ATSP
AGENCY OF TRANSPORTATION
STORAGE FACILITY PROJECT

SEALBORO, VERMONT

SECTIONS & DETAILS

DATE: 0113
 PROJECT NUMBER: 0113
 17 JUNE 2001

ATSP
AGENCY OF TRANSPORTATION
STORAGE FACILITY PROJECT

SEALBORO, VERMONT

SECTIONS & DETAILS

DATE: 0113
 PROJECT NUMBER: 0113
 17 JUNE 2001

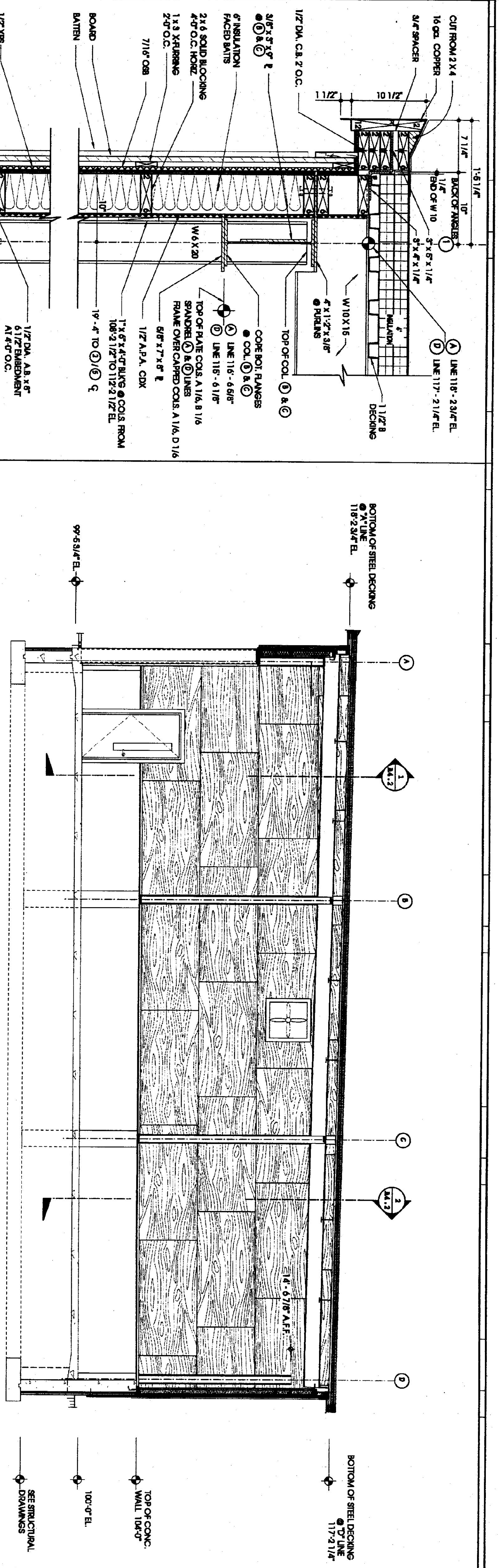

2 INTERIOR ELEVATION/SECTION (LOOKING TOWARDS #1 COLUMN LINE)

1/4" = 1'-0"
M.A.3

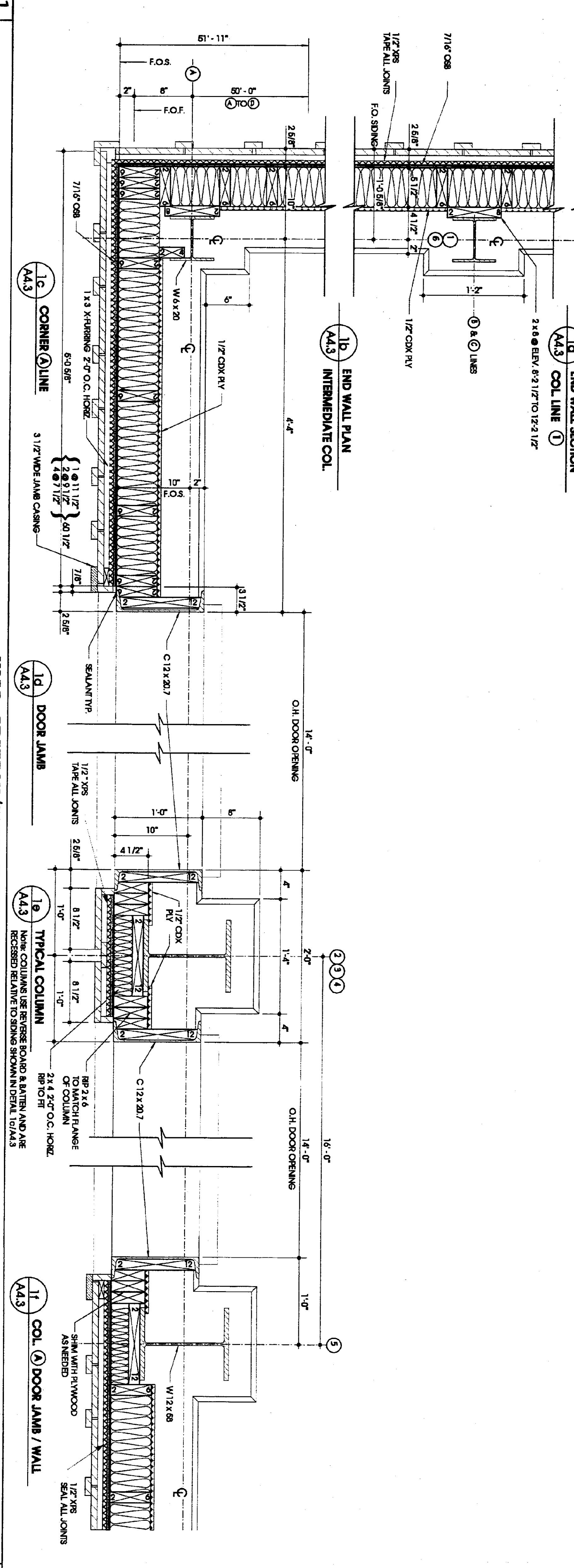

1 WALL SECTION/PLAN SECTION

1/4" = 1'-0"
M.A.3

The Design Studio of
LineSync Architecture
14 Corbin Hill Washington Vermont 05405 7745 USA
V.802.444.2526 / F.2.028
www.linesync.com

- STATE HIGHWAY GARAGE GENERAL NOTES**
- PROJECT TO CONFORM TO LOCALITIES WITH THE NEAREST APPLICABLE CODES AND REGULATIONS. THE NATIONAL ELECTRICAL CODE AND THE NATIONAL FIRE ALARM CODE SHALL APPLY TO THE PROJECT. THE JURISDICTION SHALL APPLY TO THE PROJECT. THE BUSINESS (SIMILAR TO FIRE STATION).
 - THE CONTRACTOR SHALL VERIFY CONDITIONS AND DIMENSIONS IN FIELD PRIOR TO SUBSTITUTION.
 - ALL BRACING IN CONTACT WITH CONCRETE AND MASONRY TO BE PROTECTED WITH 1/2" WOOD.
 - COORDINATE ALL DRAWINGS WITH PROJECT MANUAL.
 - ASPECTS OF THE ELEVATION SHALL BE THE RESPONSIBILITY OF THE ARCHITECT. THE ARCHITECT SHALL BE RESPONSIBLE FOR THE ELEVATION OF 3/4" OF THE ELEVATION.

- PROJECT DRAWING LIST**
- 01 CIVIL BY ENGINEER/ARCHITECT
 - 02 SITE PLAN
 - 03 LAYOUT PLAN
 - 04 ROAD PROFILE
 - 05 ROAD CROSS SECTION
 - 06 SITE DETAILS
 - 07 SITE DETAILS
 - 08 GARAGE & DRIVEWAY BY ENGINEER/ARCHITECT
 - 09 INTERIOR LOCATION MAP & DIMENSIONS
 - 10 ELEVATIONS
 - 11 1ST FLOOR PLAN
 - 12 MEZZANINE/2ND FLOOR PLAN, WINDOW/DOOR SCHEDULE
 - 13 INTERIOR ELEVATIONS & SECTIONS
 - 14 WALL SECTIONS & DETAILS
 - 15 WINDOW & FAIR DETAILS
 - 16 DETAILS
 - 17 GARAGE STRUCTURAL BY BUILDING ASSOCIATES
 - 18 GEN STRUCT NOTES & STANDARD DETAILS
 - 19 FOUNDATION PLAN
 - 20 ROOF PLAN
 - 21 STRUCTURAL SECTIONS & DETAILS
 - 22 STANDARD STRUCTURAL DETAILS
 - 23 ELECTRICAL BY ENGINEER/ARCHITECT
 - 24 ELECTRICAL SITE PLAN
 - 25 FIRST FLOOR PLAN (INCLUDES MEZ.)

- GARAGE ARCHITECTURAL NOTES BY PART OF STATE BLDGS**
- M1 GARAGE OVERHANGING
 - M2 GARAGE OVERHANGING
 - M3 A.O.T. 2" x 4" STUDS @ 24" O.C. W/STRUCT
 - M4 A.O.T. 4" x 8" SILL & BAND BEAMS W/STRUCT
 - M5 VENTILATION SYSTEM PLANS & DETAILS

NO.	DATE	REVISIONS
1	20 NOV 01	ISSUED FOR STATE REVIEW
2	07 FEB 02	ISSUED FOR BID

ATNSF
AGENCY OF TRANSPORTATION
STORAGE FACILITY PROJECT

RENDERED BY: VERMONT

INTERIOR ELEVATIONS & WALL SECTION

SCALE - ONE INCH = ONE FOOT

DATE: 17 JUNE 2001

PROJECT NUMBER: 0113

DATE: 17 JUNE 2001

DESIGNED BY: [Signature]

SCALE: 1/4" = 1'-0"

17 JUNE 2001

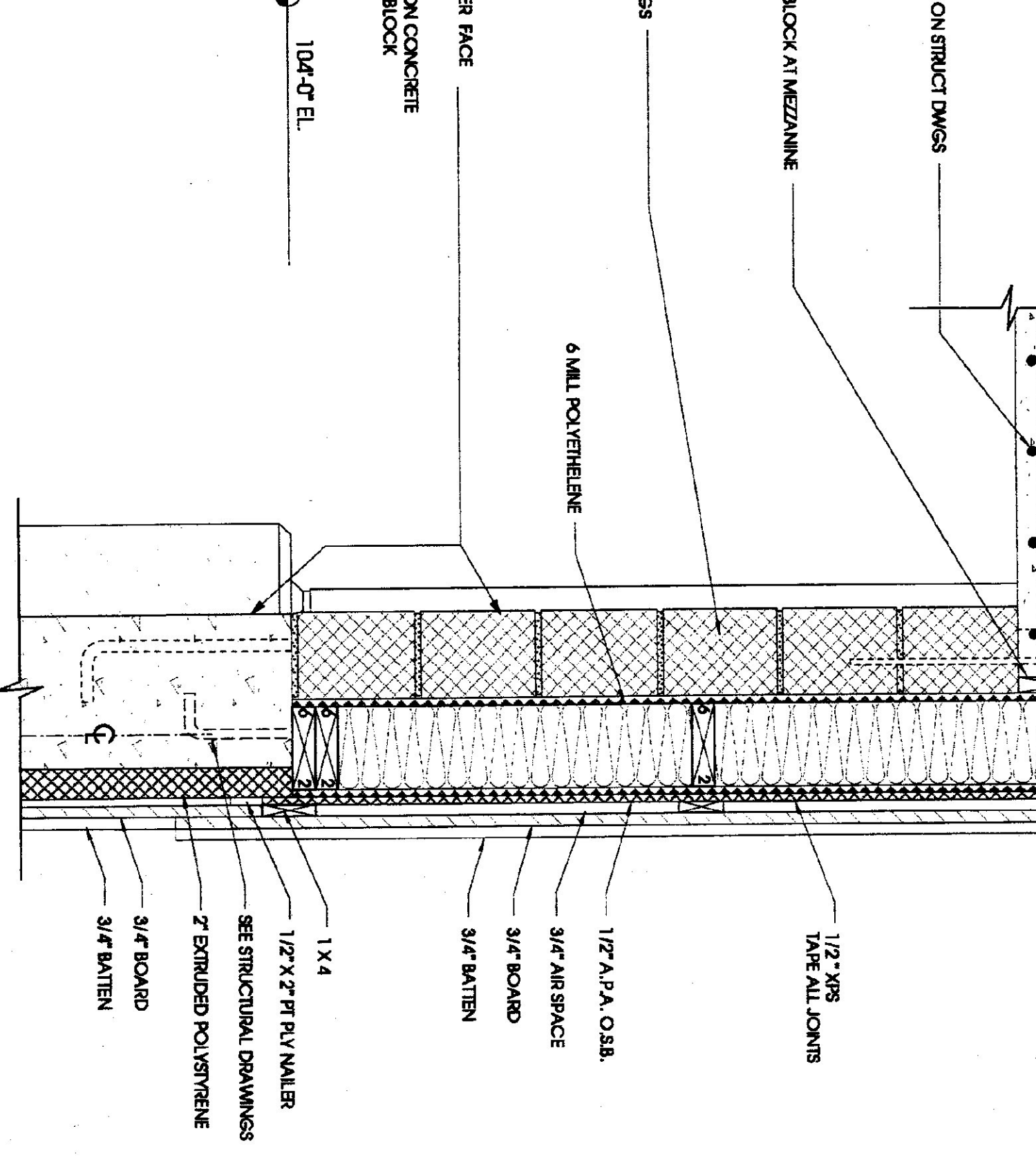
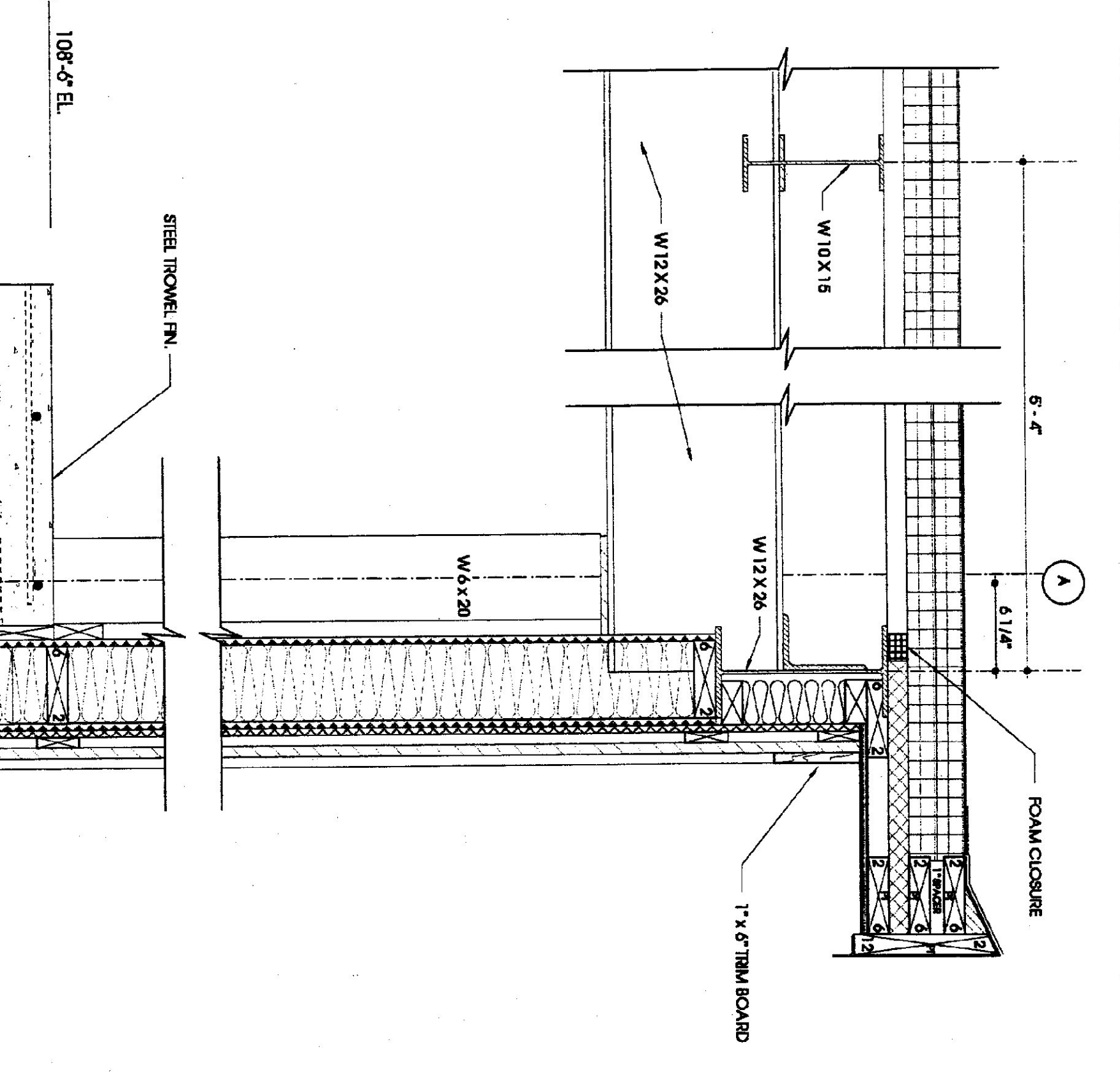
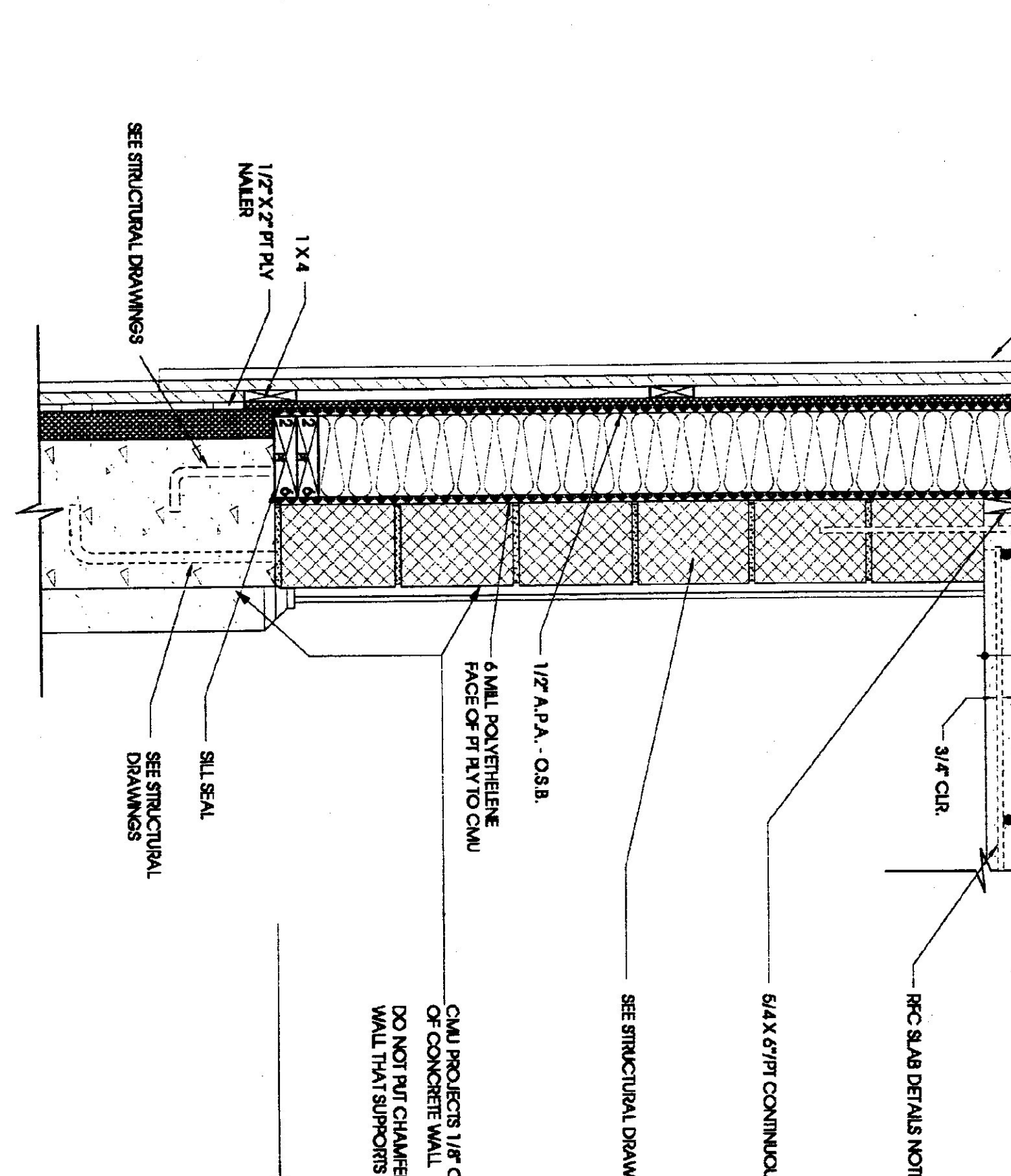
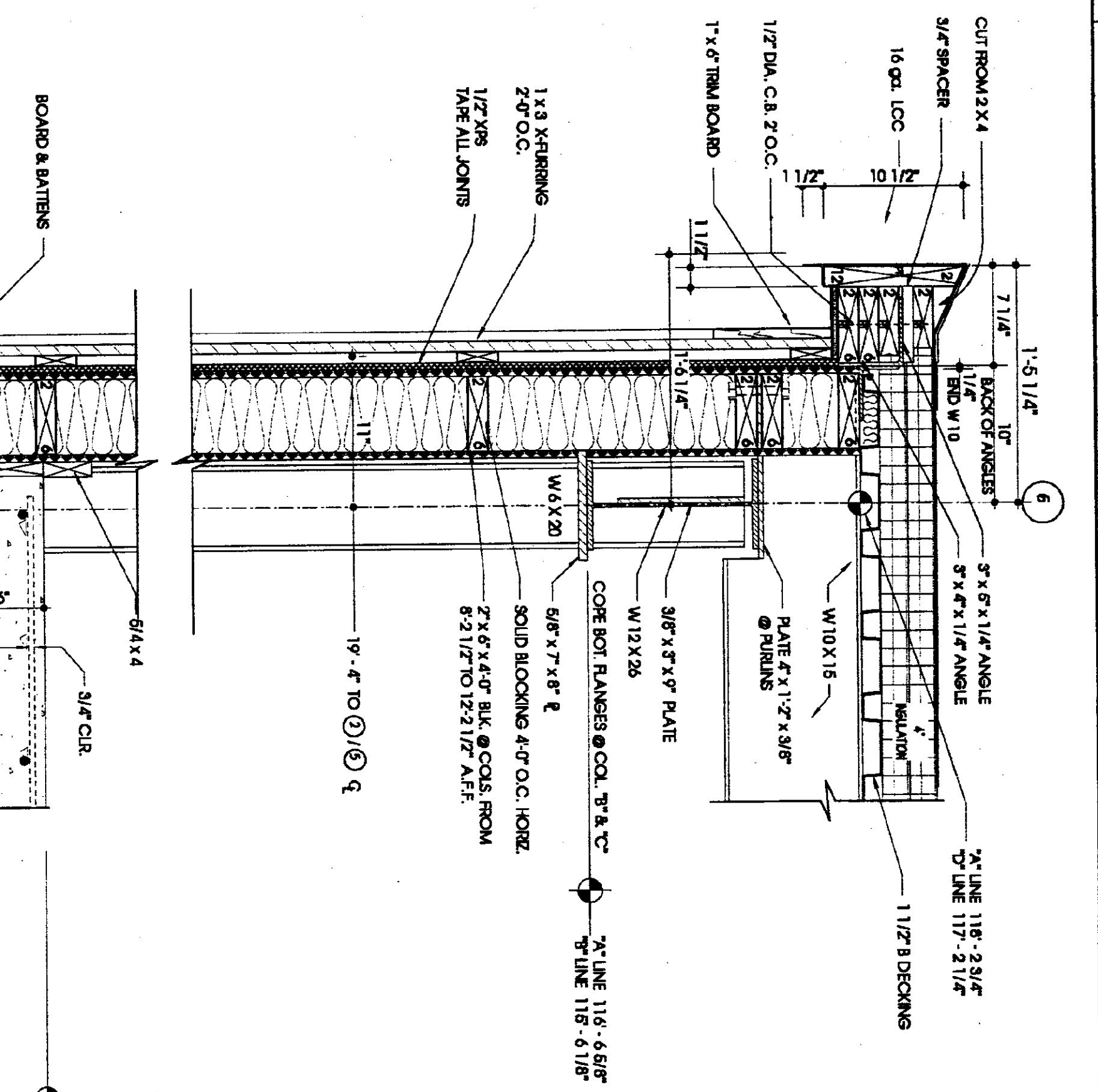
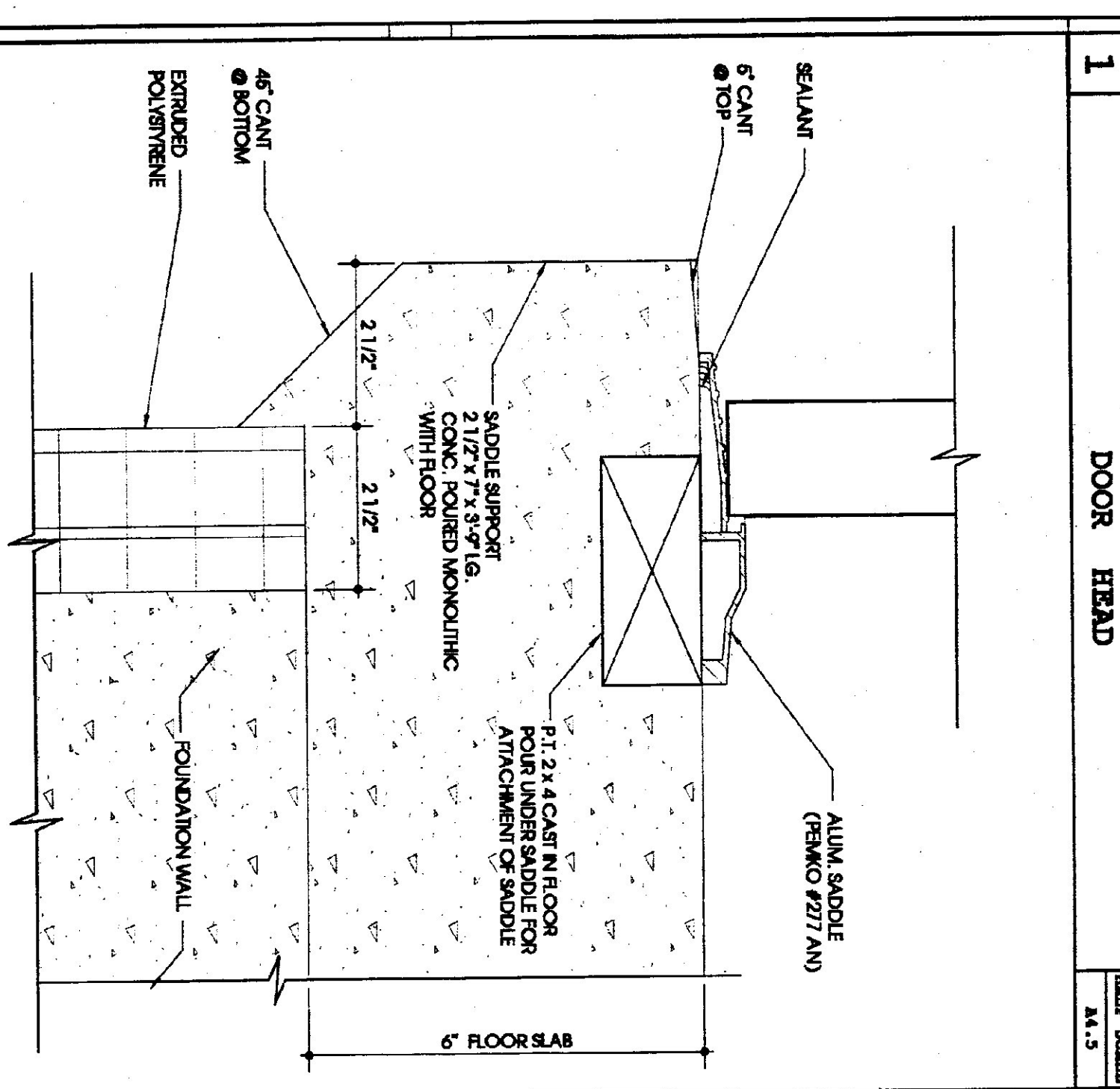
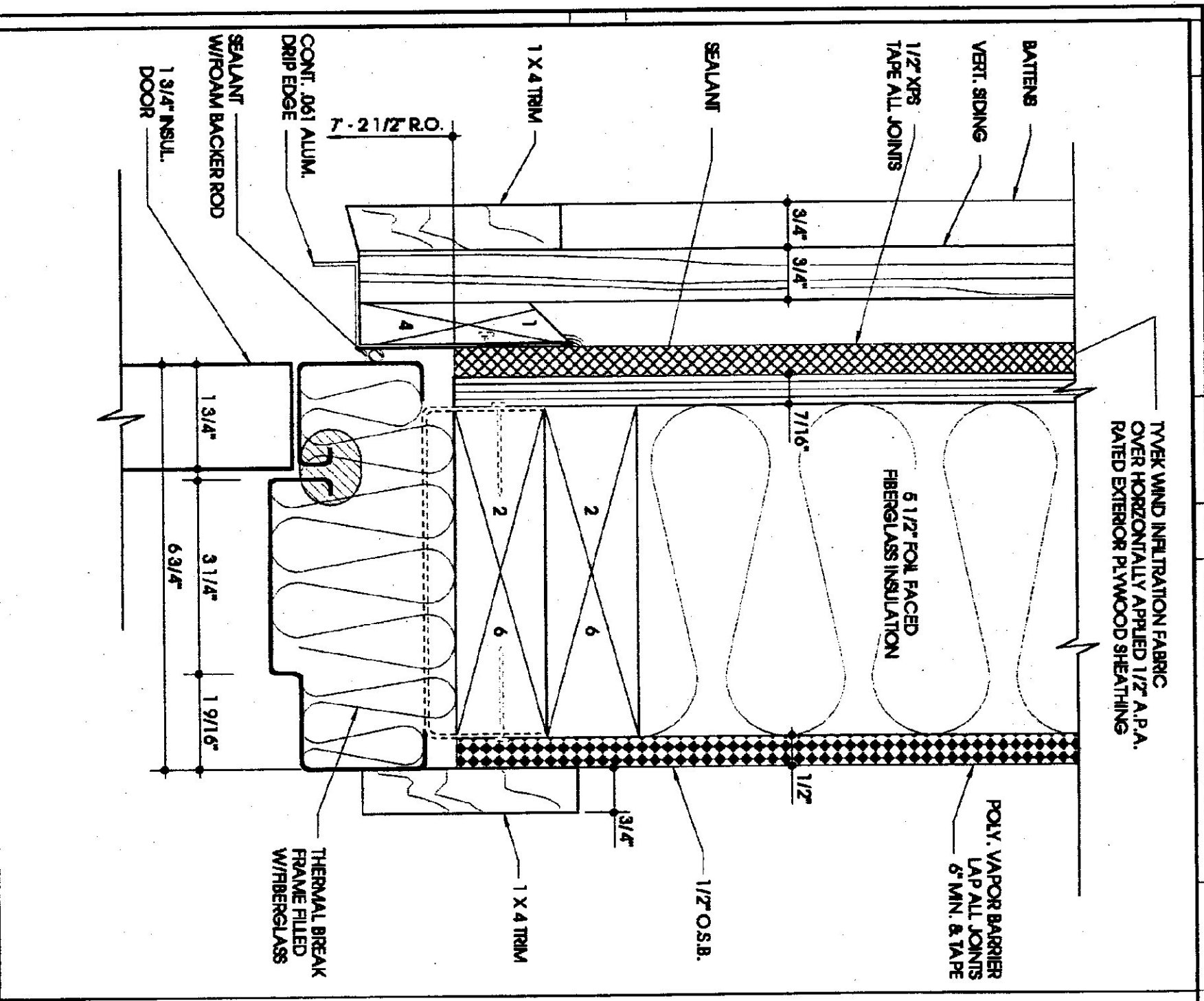

THE DESIGN STUDIO OF
Linesync Architecture
 14 Canal Hill, Watlington, Vermont 05683 9746 USA
 1-802-244-2526 / 1-252-2526
 www.linesync.com

STATE HIGHWAY GARAGE GENERAL NOTES

- PROJECT TO COMPLY TO REGULATIONS WITH THE NATIONAL ELECTRICAL CODE AND THOSE REQUIRED BY LOCAL AND STATE AUTHORITIES HAVING JURISDICTION OVER THE WORK. LOCAL REQUIREMENTS SHALL BE SHOWN ON THE PROJECT'S BUSINESS SIMILAR TO THIS SECTION.
- THE CONTRACTOR SHALL VERIFY CONDITIONS AND DIMENSIONS IN FIELD PRIOR TO REVISION.
- ALL FRAMING IN CONTACT WITH CONCRETE AND MASONRY TO BE FINISHED WITH 2\"/>

PROJECT DRAWING LIST

CIVIL BY DEFENSE-HENRY
 C1 SITE PLAN
 C2 LAYOUT PLAN
 C3 6\"/>

GARAGE & OFFICES BY LINESYNC ARCHITECTURE
 A11 SITE PLAN, LOCATION MAP & REFERENCES
 A12 ELEVATIONS
 A13 1ST FLOOR PLAN
 A14 2ND FLOOR PLAN, WINDOW/DOOR SCHEDULE
 A15 SECTION DETAILS
 A16 INTERIOR ELEVATIONS
 A17 INTERIOR ELEVATIONS & SECTIONS
 A18 WALL SECTIONS & DETAILS
 A19 WINDOW & FRAM DETAILS
 A20

GARAGE MECHANICAL BLDG BY DEPT OF STATE BLDGS
 M1 GARAGE MECHANICAL PLAN
 M2 GARAGE MECHANICAL/ELECTRICAL/PLUMBING/MECHANICAL
 M3 A.O.T. 2\"/>

NO.	DATE	REVISIONS
1	20 NOV 01	ISSUED FOR STATE REVIEW
2	07 FEB 02	ISSUED FOR BID

ATSP
AGENCY OF TRANSPORTATION
STORAGE FACILITY PROJECT

REASONBORG, VERMONT

WALL SECTIONS & DETAILS

DATE - 098 1008
 PROJECT NUMBER
 0113
 17 JUNE 2001
 DRAWING DATE

SCALE
 1/2\"/>

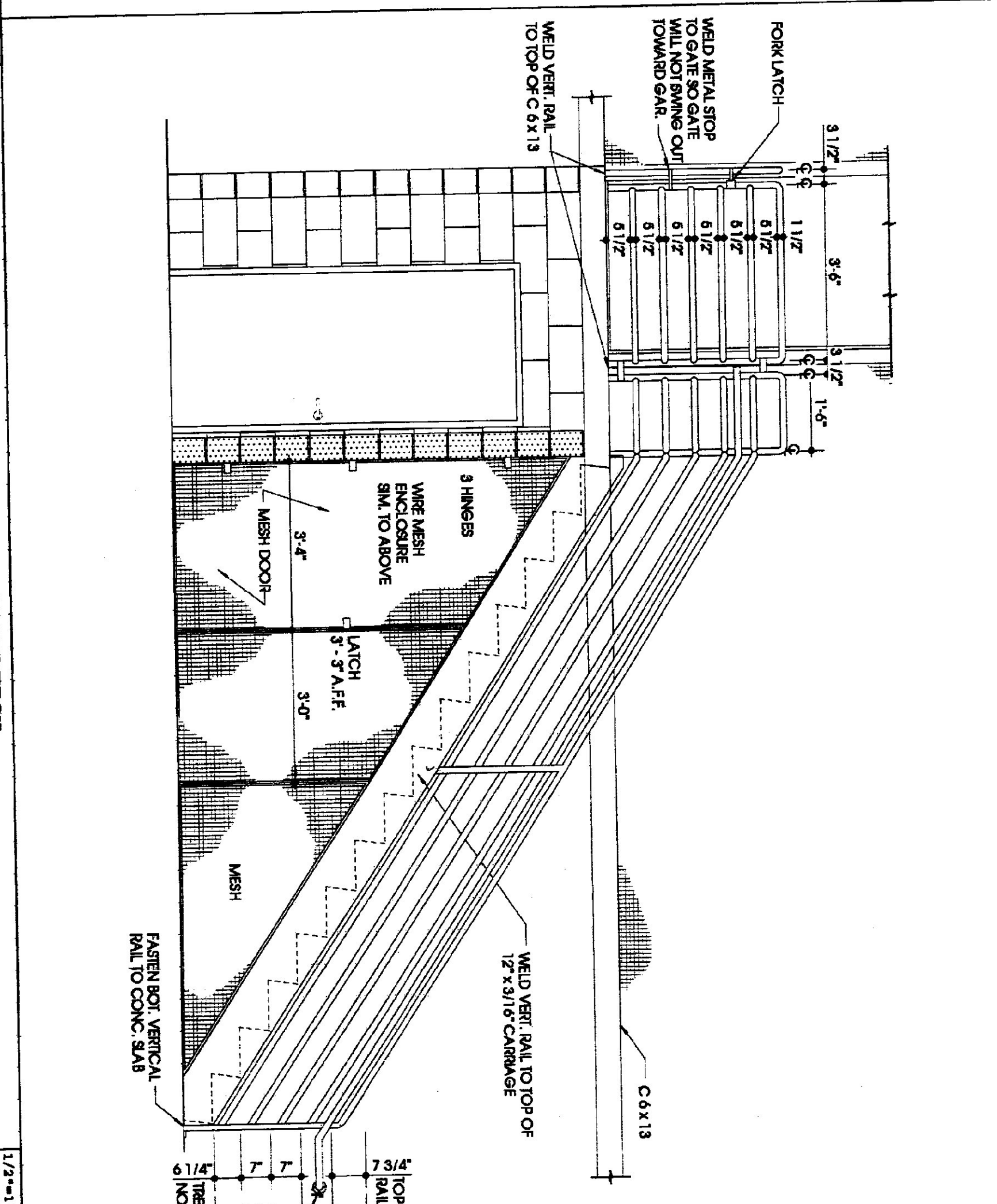
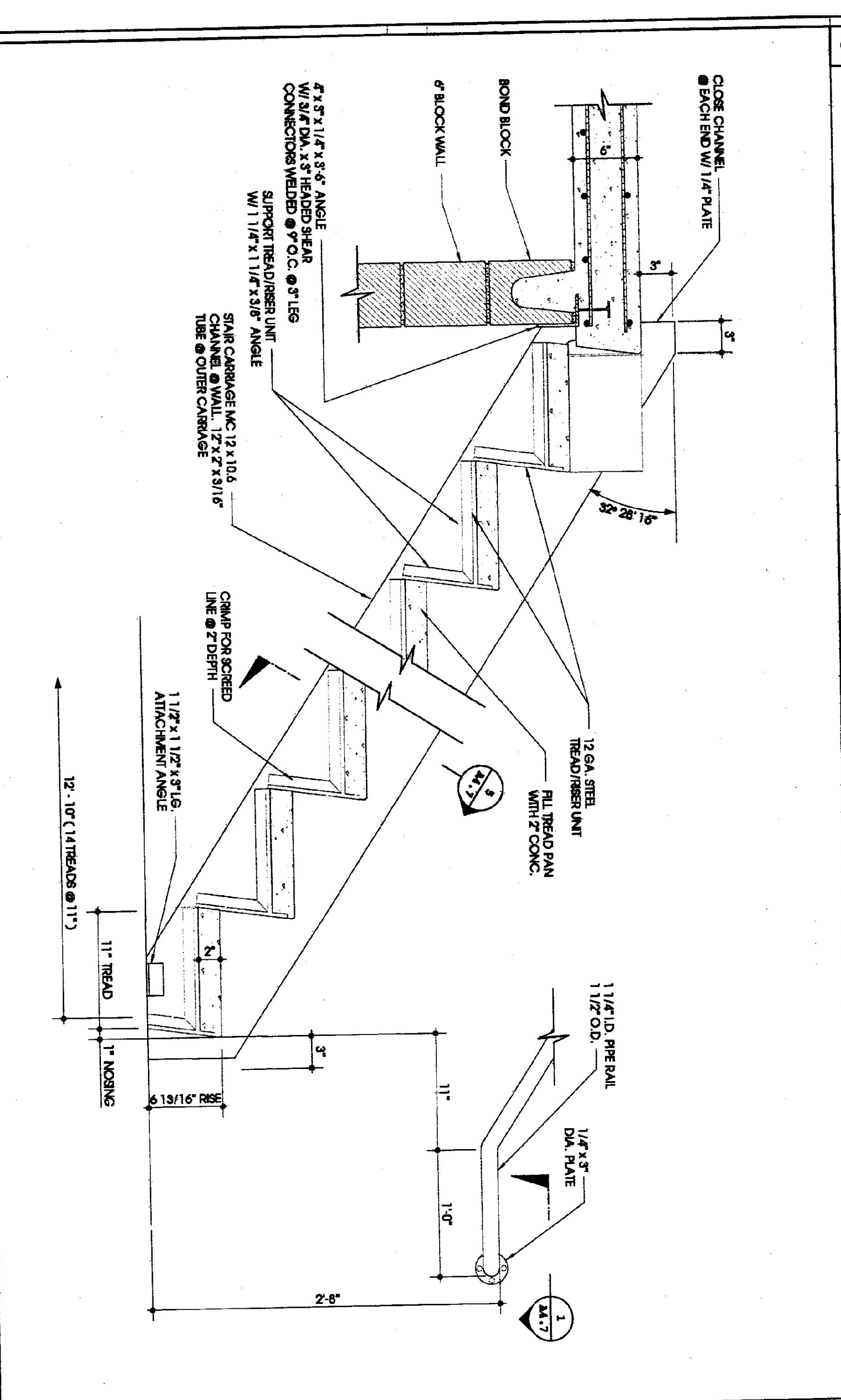
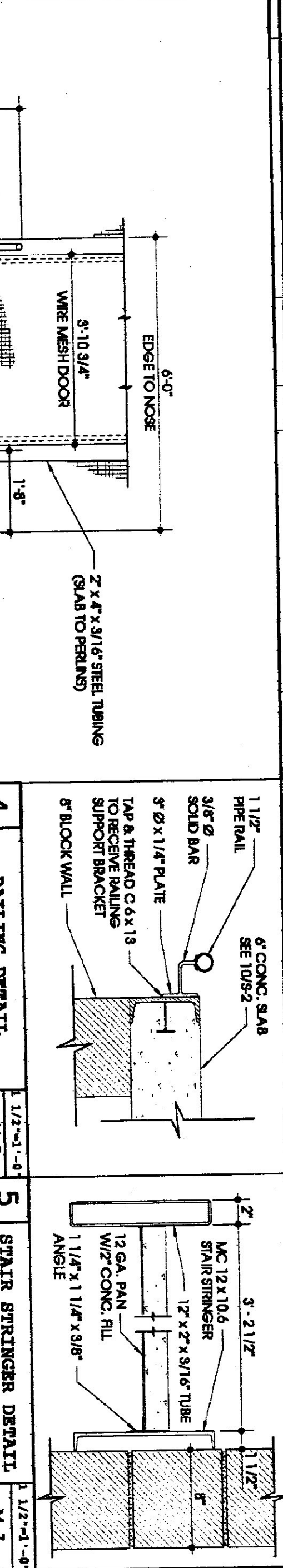
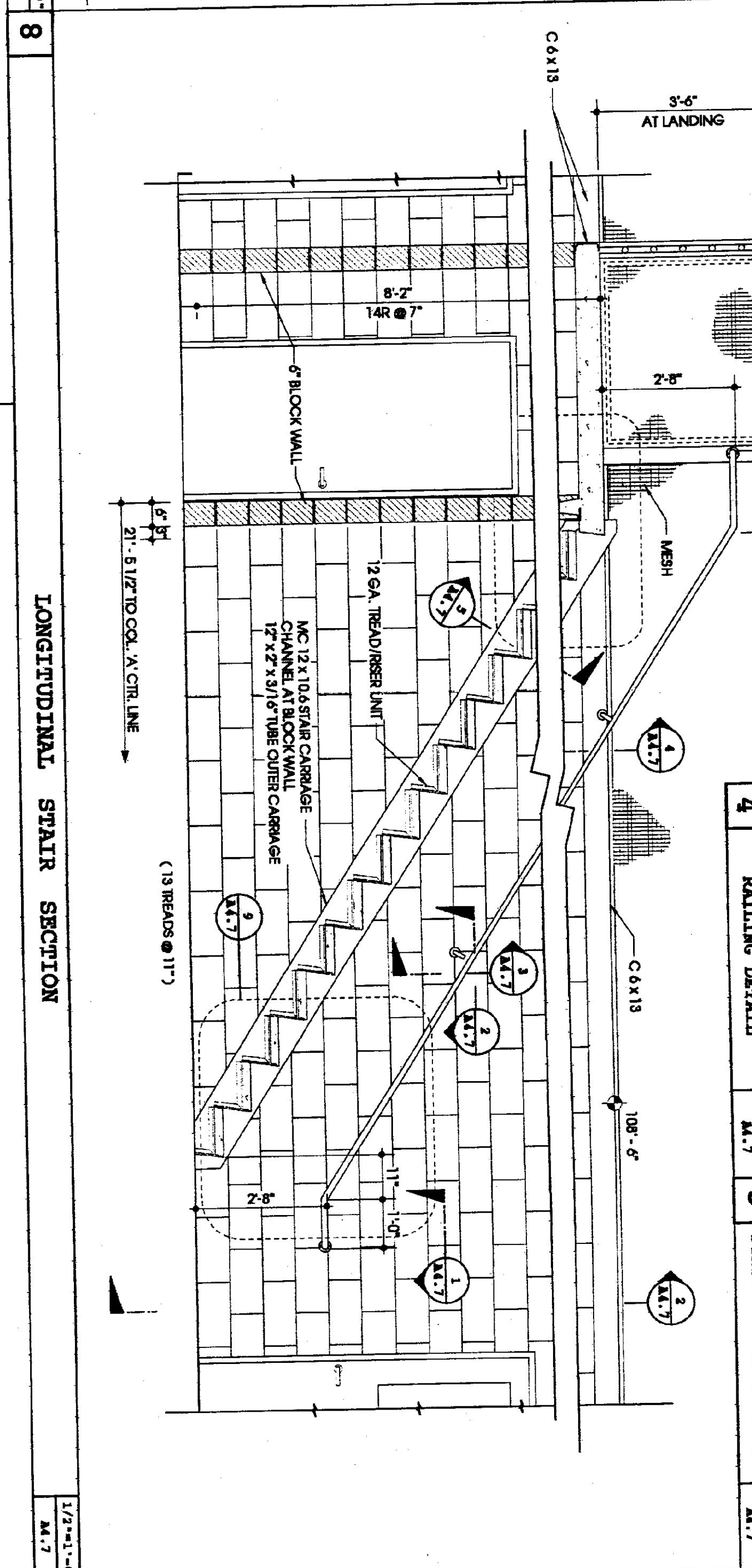
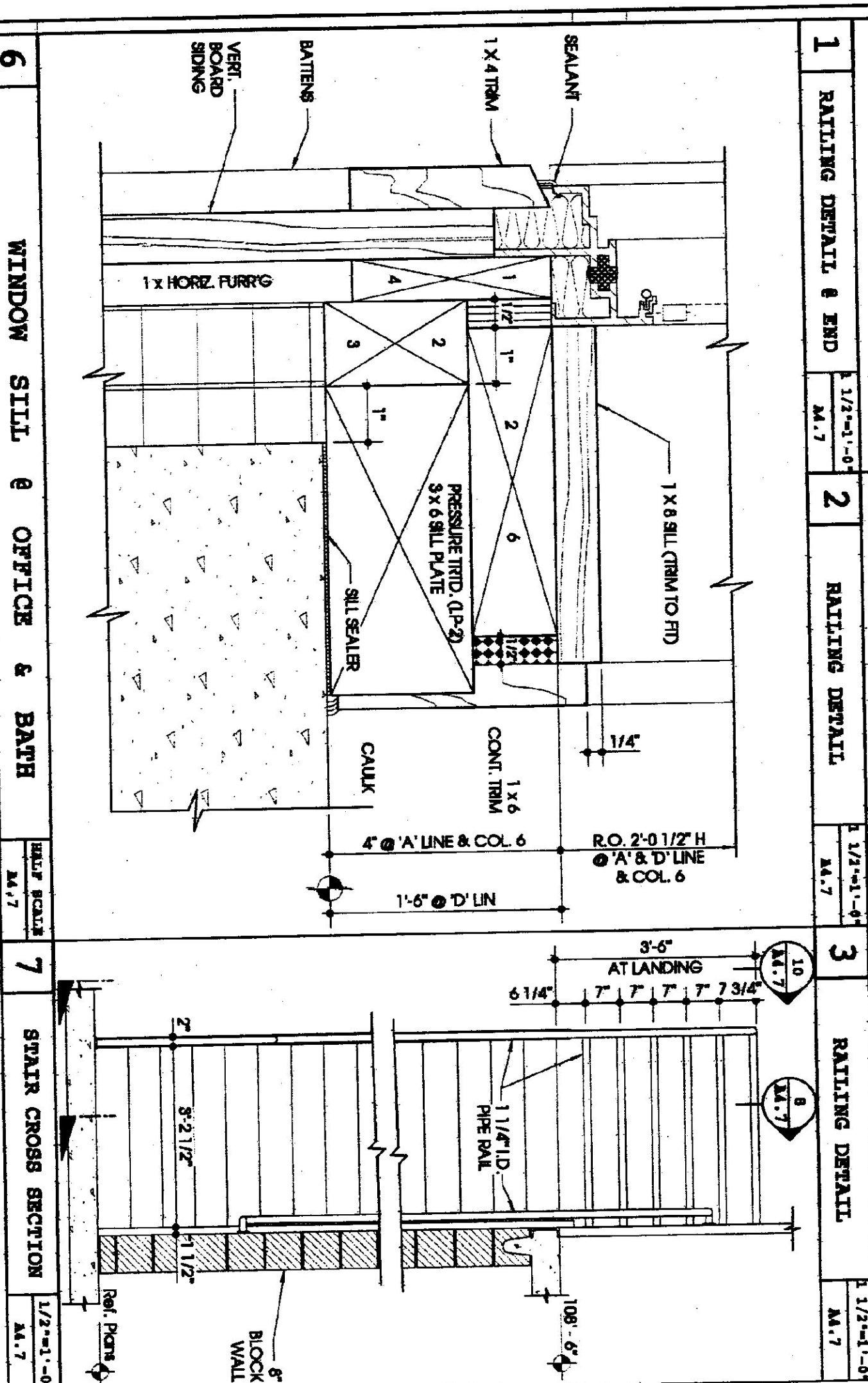
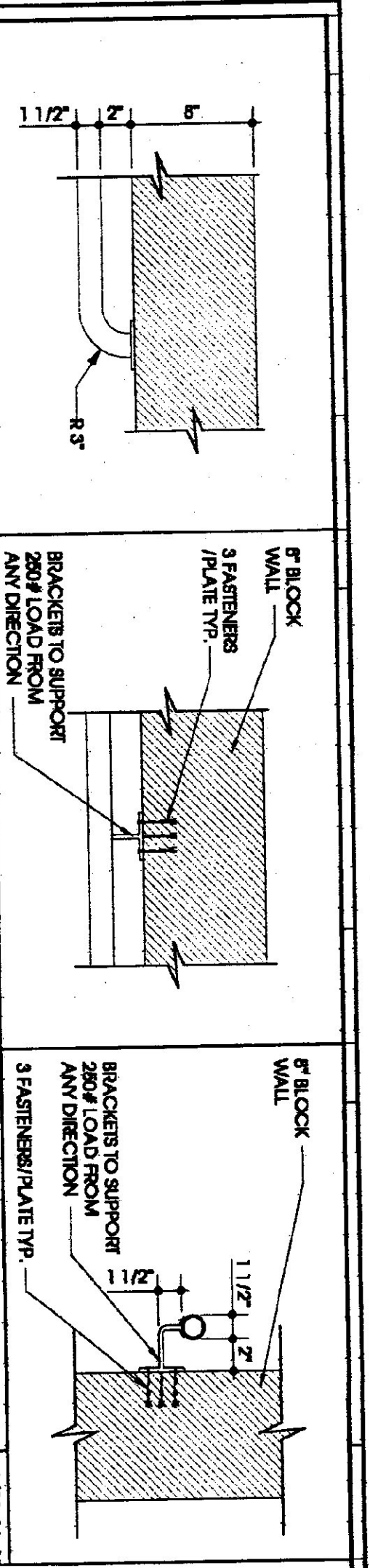

The Design Studio of
Linesync Architecture
1100 14th Street, NW, Suite 1000, Washington, DC 20005
Tel: 202.462.2525 / Fax: 202.462.2528
www.linesync.com

- STATE HIGHWAY GARAGE GENERAL NOTES**
- PROJECT TO CONFORM TO LOCAL CODES WITH THE NATIONAL ELECTRICAL CODE AND THE NATIONAL MECHANICAL AND PLUMBING CODES AS THE NATIONAL ELECTRICAL CODE AND THE NATIONAL MECHANICAL AND PLUMBING CODES ARE INVOLVED BY THIS WORK. LOCAL CODES SHALL BE OBSERVED BY THE CONTRACTOR.
 - THE CONTRACTOR SHALL VERIFY CONDITIONS AND DIMENSIONS IN FIELD PRIOR TO REVISION.
 - ALL BRACING IN CONTACT WITH CONCRETE AND MASONRY TO BE PRESERVED OR TREATED WOOD.
 - COORDINATE ALL DRAWINGS WITH PROJECT MANUAL.
 - ARCHITECTURAL ELEVATION SHALL BE REFERENCED TO THE DATE OF THE ARCHITECTURAL ELEVATION DRAWING. THE CONTRACTOR SHALL BE RESPONSIBLE FOR THE DATE OF THE ARCHITECTURAL ELEVATION DRAWING.
- PROJECT DRAWING LIST**
- CIVIL BY DESIGN-BUILDERS
 C1 LAYOUT PLAN
 C2 ROAD PROFILE
 C3 ROAD CROSS SECTIONS
 C89 SITE DETAILS
 C1011 SITE DETAILS
- GARAGE & OFFICE BY DESIGN-BUILDERS
 A11 SITE PLAN, LOCATION MAP & PERMITS
 A12 ELEVATION
 A21 ELEVATION
 A31 1ST FLOOR PLAN
 A32 MEZZANINE FLOOR PLAN, WINDOW/DOOR SCHEDULE
 A41 SECTION DETAILS
 A42 INTERIOR ELEVATIONS & SECTIONS
 A43 INTERIOR ELEVATIONS & SECTIONS
 A44 WALL SECTIONS & DETAILS
 A45 WINDOW & STAIR DETAILS
- GARAGE STRUCTURAL BY STEELMAN ASSOCIATES
 S01 GENERAL NOTES & STANDARD DETAILS
 S02 FOUNDATION PLAN
 S03 ROOF FRAMING PLAN
 S112 STRUCTURAL SECTIONS & DETAILS
 S113 STRUCTURAL SECTIONS & DETAILS
 S114 STRUCTURAL SECTIONS & DETAILS
 S115 STRUCTURAL SECTIONS & DETAILS
 S116 STRUCTURAL SECTIONS & DETAILS
 S117 STRUCTURAL SECTIONS & DETAILS
 S118 STRUCTURAL SECTIONS & DETAILS
 S119 STRUCTURAL SECTIONS & DETAILS
 S120 STRUCTURAL SECTIONS & DETAILS
 S121 STRUCTURAL SECTIONS & DETAILS
 S122 STRUCTURAL SECTIONS & DETAILS
 S123 STRUCTURAL SECTIONS & DETAILS
 S124 STRUCTURAL SECTIONS & DETAILS
 S125 STRUCTURAL SECTIONS & DETAILS
 S126 STRUCTURAL SECTIONS & DETAILS
 S127 STRUCTURAL SECTIONS & DETAILS
 S128 STRUCTURAL SECTIONS & DETAILS
 S129 STRUCTURAL SECTIONS & DETAILS
 S130 STRUCTURAL SECTIONS & DETAILS

No.	DATE	REVISIONS
1	20 NOV 01	ISSUED FOR STATE REVIEW
2	07 FEB 02	ISSUED FOR BID

DESIGNED BY: [Signature]
 DRAWN BY: [Signature]
 CHECKED BY: [Signature]
 DATE: 17 JUNE 2001

ATSP
AGENCY OF TRANSPORTATION
STORAGE FACILITY PROJECT

REARBOARD, VERMONT
WINDOW & STAIR
DETAILS

PROJECT NUMBER: 0113
 DATE: 17 JUNE 2001

SCALE: 1/2"=1'-0"
 DRAWN BY: [Signature]
 CHECKED BY: [Signature]

DIVISION 1 - GENERAL REQUIREMENTS

SHIELD AND PROTECTION

- 1. Contractor shall be responsible for maintaining and supervising all safety precautions and protective measures...
2. Contractor shall comply with all applicable laws, ordinances, rules, regulations and orders...
3. Contractor's duties and responsibilities for the safety and protection of the work shall continue until such time as all the work is completed.

COLD WEATHER CONSTRUCTION PROCEDURES

- 1. It shall be the Contractor's responsibility to continuously protect walls, concrete, masonry and other building materials from damage due to cold temperatures...
2. It shall be the Contractor's responsibility to repair and/or replace any damaged or defective work, in a manner approved by the Engineer.

DIVISION 2 - SITEWORK

GENERAL REQUIREMENTS

- 1. All existing materials, debris and any other deleterious material shall be removed prior to placing the greater fill.
2. Greater fill shall be an approved, well graded bank run or crusher run gravel meeting the requirements of the following table:

Table with 3 columns: SIZE DESIGNATION, % PASSING, and No. 100, No. 200. Values range from 100% to 4-8%.

- 3. It shall be the Contractor's responsibility to obtain, from a testing firm approved by the Engineer, a series of laboratory moisture-density curves for the proposed greater fill.
4. The greater fill material shall be placed in maximum 6" lifts and compacted to 95% of maximum density at optimum moisture content as determined by ASTM D1557, modified procedure.
5. All materials shall be placed in such a way as not to damage concrete foundations and footings.

80 ALTERNATE #2
Provide Final Final Station Foundation System (FSS) in lieu of standard station foundation system (SFS) (A.02.2 - 5-27' below grade) Refer to Drawing S31 for details for alternate FSS System.

DIVISION 3 - CONCRETE

GENERAL REQUIREMENTS

- 1. All structural concrete shall be cast in accordance with the site, architectural, mechanical, electrical and plumbing drawings and specifications.
2. All concrete work shall comply with the latest recommendations and specifications of the American Concrete Institute (ACI) and the local building codes.

Table with 2 columns: Material, and ASTM C150, Type II. Values include 4250 psi and 4000 psi.

- 4. All reinforcing steel shall comply with ASTM A615, grade 60. Lap at least 50 diameters minimum of splices unless indicated otherwise on the Drawings.
5. Reinforcement shall be securely tied in its proper place before and during placing operations using approved chairs and spacers as required (chairs may not be used as bar supports).

- 13. Proper selection of all concrete is essential. The Contractor shall make provisions for hot-dry weather equipment.
14. The Contractor shall install (or give other trades ample opportunity to install) all anchors, bolts, plates, nuts, washers, pipe, sleeves, etc., as required by other trades.

- 15. Foundation walls shall be placed in alternate lengths, each pour not to exceed approximately 40 feet in length. No horizontal joints shall be permitted except as shown on plans.
16. Provide finished concrete and steel reinforcement.
17. Concrete temperature during the first seven days shall be maintained between 50 F and 90 F.
18. Outing: a. Surface shall be prepared as follows: - Cutting shall be completed as follows: - After 7 days, apply a curing/sealing compound (Water-Cast Seal No. 10 by Sonotone).

22. The Owner will employ a qualified outside testing firm to perform standard field tests for concrete work. All concrete action and follow-up testing for materials involved will be at the Contractor's expense.

DIVISION 4 - MASONRY

GENERAL REQUIREMENTS

- 1. Concrete masonry shall comply with the applicable sections of the National Concrete Masonry Association, Portland Cement Association and American Concrete Institute codes.
2. Concrete masonry units shall be normal weight, hollow load-bearing, ASTM C90, Grade N, 16" x 16" x 8" minimum compressive strength on the net area of 2000 psi, two cells with minimum 50% solid.

- 4. Cast-in-place concrete shall comply with the above codes. Deformed bars shall conform to ASTM A615 Grade 60, cast-in-place steel shall conform to ASTM A615 Grade 60.
5. Horizontal and vertical reinforcing shall comply with the above codes. Deformed bars shall conform to ASTM A615 Grade 60, cast-in-place steel shall conform to ASTM A615 Grade 60.

- 11. All load beams, walls and jam blocks, unless otherwise noted, shall be reinforced with (2) #4 bars.
12. Fit of walls and blocks shall comply with that of a distance of 2" between and 1/2" each side of all beam reactions or other concentrated loads.
13. No splices in reinforcing bars shall be made except as indicated or approved by Structural Engineer. Where necessary, all splices shall be lapped 50 bar diameters.

DIVISION 5 - METALS

GENERAL REQUIREMENTS

- 1. All structural steel and steel shall conform to the AISC "Specification for Design, Fabrication and erection of Structural Steel Buildings" and to the requirements of the local Building Code.
2. Dimensional tolerances shall comply with latest edition of "Code of Standard Practice for Steel Buildings and Bridges".

- 4. All field connections shall be bolted except where welding is specifically called for.
5. Structural Steel Contractor shall provide all necessary girding and bracing required to erect and hold steel frame panels and secure until roof deck and permanent bracing are installed.
6. There will be no lead burning cutting or other alterations of primary structural steel without the written permission of the Engineer.

- 9. Non-shrink grout (below column base plates and other specified locations) shall be Emenco 636 as manufactured by Master Builders (or approved equal). The grout shall be applied in accordance with Manufacturer's specifications. Min. 28 days strength of 8000psi is required.
10. Wood construction shall comply with the following codes and regulations in addition to the local Building Code:
A. "Timber Construction Manual" by the American Institute of Timber Construction.
B. "National Design Specification for Wood Construction" and "Design Values for Wood Construction" by the National Forest Products Association.
C. "American Softwood Lumber Standard" by the National Bureau of Standards.
D. "Timber Design Specification" by the American Plywood Association.
E. "Softwood Plywood, Construction and Installation" - U.S. Product Standard PS-66.
F. Voluntary Product Standard PS-56-71, "Structural Glued Laminated Timber".

22. The Owner will employ a qualified outside testing firm to perform standard field tests for concrete work. All concrete action and follow-up testing for materials involved will be at the Contractor's expense.

DIVISION 6 - WOOD AND PLASTICS

GENERAL REQUIREMENTS

- 1. All wood construction shall comply with the following codes and regulations in addition to the local Building Code:
A. "Timber Construction Manual" by the American Institute of Timber Construction.
B. "National Design Specification for Wood Construction" and "Design Values for Wood Construction" by the National Forest Products Association.
C. "American Softwood Lumber Standard" by the National Bureau of Standards.
D. "Timber Design Specification" by the American Plywood Association.
E. "Softwood Plywood, Construction and Installation" - U.S. Product Standard PS-66.
F. Voluntary Product Standard PS-56-71, "Structural Glued Laminated Timber".

- 2. Lumber for structural framing (including joists, rafters, beams, columns and studs) shall be Species-Pre-Fir, No. 1/No.2 grade or better. Minimum allowable design stresses shall be as follows: (100% Load Duration)
Fb (Bending) = 875 psi
Fv (Shear) = 70 psi
Fc (Compression with grain) = 1,100 psi
E (Modulus of Elasticity) = 1,400,000 psi

- 7. All wood framing construction shall be erected true to the end dimensions well fastened and properly braced.
8. Piles of plywood with face grain perpendicular to supports and field continuously over at least two supports with joints centered over one support.
9. All wood members in contact with concrete, masonry, and/or ground shall be pressure treated.

DIVISION 7 - CONSTRUCTION CRITERIA

DESIGN CRITERIA

- 1. Applicable Building Code: The BCMA National Building Code (1996)
2. Design and loading capacity: 3000 PSF
3. Design loads:
a. DEAD LOAD: 20 PSF
b. LIVE LOAD: 125 PSF
c. SNOW LOAD: 50 PSF
d. WIND LOAD: 16.4 PSF
e. SEISMIC: Exposure C

- 1. All structural steel and steel shall conform to the AISC "Specification for Design, Fabrication and erection of Structural Steel Buildings" and to the requirements of the local Building Code.
2. Dimensional tolerances shall comply with latest edition of "Code of Standard Practice for Steel Buildings and Bridges".

- 9. Non-shrink grout (below column base plates and other specified locations) shall be Emenco 636 as manufactured by Master Builders (or approved equal). The grout shall be applied in accordance with Manufacturer's specifications. Min. 28 days strength of 8000psi is required.
10. Wood construction shall comply with the following codes and regulations in addition to the local Building Code:
A. "Timber Construction Manual" by the American Institute of Timber Construction.
B. "National Design Specification for Wood Construction" and "Design Values for Wood Construction" by the National Forest Products Association.
C. "American Softwood Lumber Standard" by the National Bureau of Standards.
D. "Timber Design Specification" by the American Plywood Association.
E. "Softwood Plywood, Construction and Installation" - U.S. Product Standard PS-66.
F. Voluntary Product Standard PS-56-71, "Structural Glued Laminated Timber".

22. The Owner will employ a qualified outside testing firm to perform standard field tests for concrete work. All concrete action and follow-up testing for materials involved will be at the Contractor's expense.

ABBREVIATIONS

Table with 2 columns: Abbreviation and Full Name. Includes AB, AD, B.O.F., B.P., etc.

DRAWING LEGEND

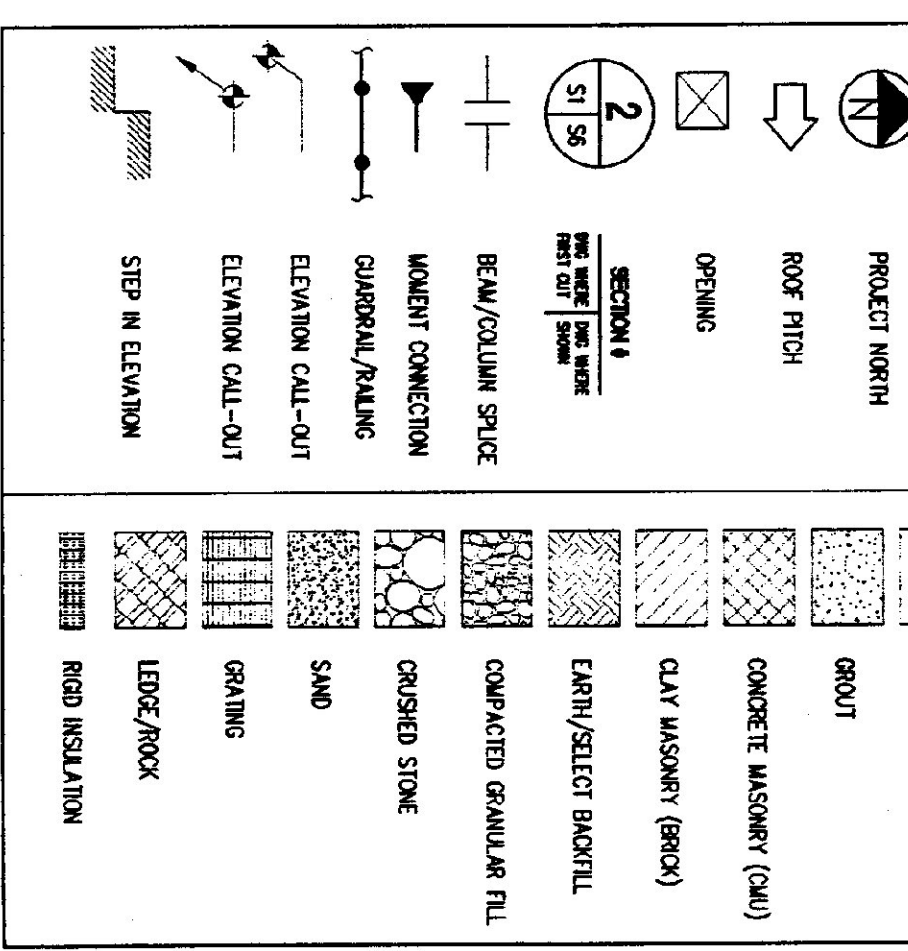

SUBMITTALS

- Contractor shall submit shop drawings and/or submittals to the Engineer for the following items:
- Concrete Formwork
- Concrete Reinforcing Steel
- Steel Reinforcing Steel
- Steel Decking
- Steel Joists
- Steel Decking
- Steel Joists
- Steel Decking
- Steel Joists

CONSTRUCTION CRITERIA

- Comply with construction requirements/recommendations of the latest editions of the following:
- ACI 308 - Specifications for Structural Concrete for Buildings
- ACI 302 - Guide for Concrete Floor and Slab Construction
- ACI 305 - Guide for Measuring, Mixing, Transporting, and Placing Concrete
- ACI 308 - Code of Practice for Concrete Reinforcement
- ACI 309 - Details and Detailing of Concrete Reinforcement
- ACI 308 - Specifications for Ready-Mix Concrete

Project title: STATE OF VERMONT READSBORO HIGHWAY GARAGE PROJECT. Includes logos for Hallam Engineering and LineSync Architecture, a revision table, and a scale of 1/8" = 1'-0".

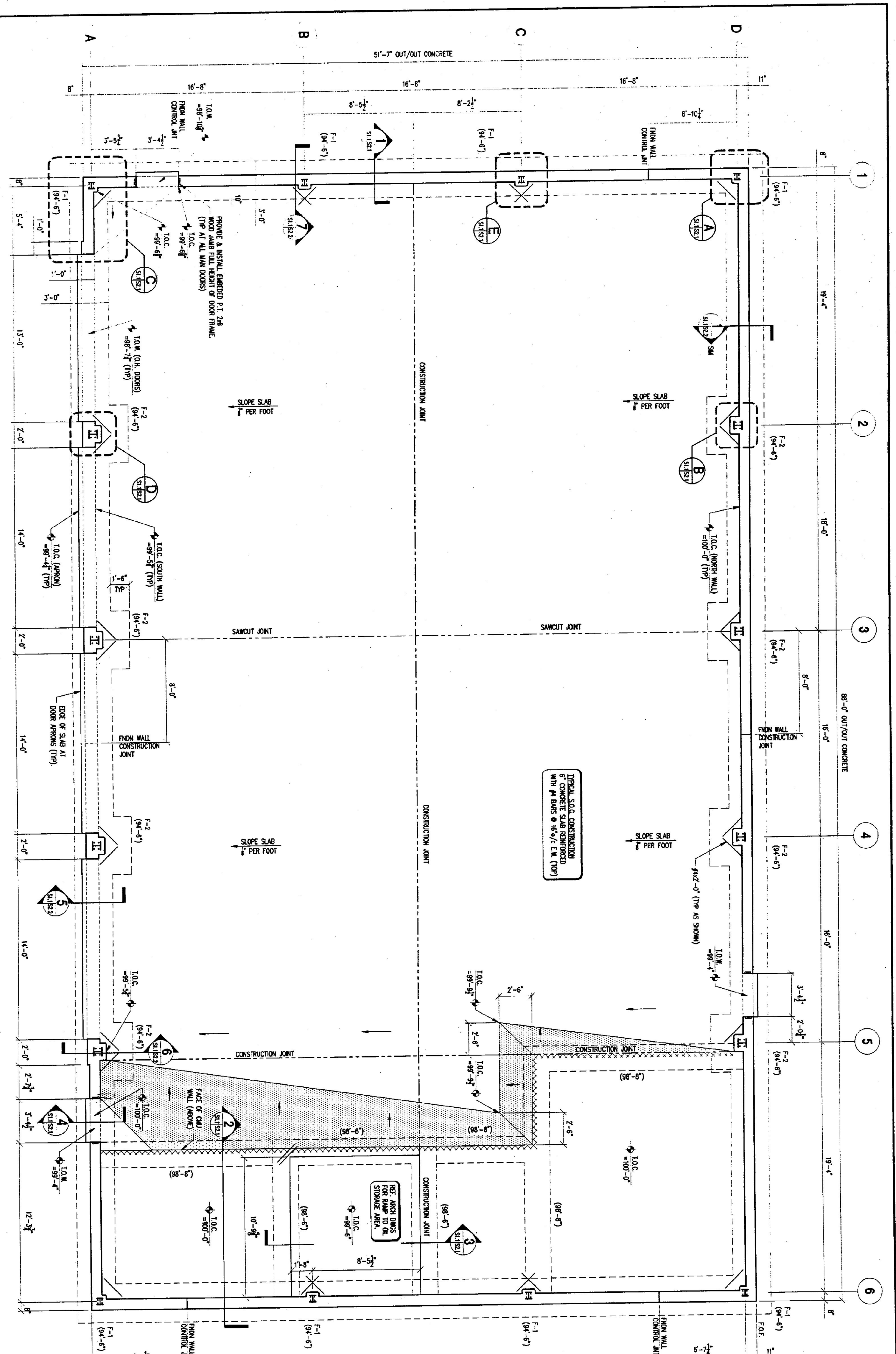

FOOTING SCHEDULE

MARK	SIZE (NOMINAL) OPEN REINFORCING (ELEV. UNO)
F-1	3'-3/4'-0" 12" #4 @ 6" E.L. W/ #4 @ 8" O.C. W/
F-2	4'-3/4'-0" 12" #4 @ 6" E.L. W/

- FOUNDATION PLAN**
1/4"=1'-0"
- NOTES:**
1. CONCRETE SLAB-ON-GRADE SHALL BE 6" THICK AND REINFORCED WITH #4 BARS @ 16" O.C. (TOP), UNO.
 2. TOP OF CONCRETE SLAB ELEVATION SHALL BE 100'-0" (UNO).
 3. BOTTOM OF FOOTING ELEVATIONS ARE NOTED ON PLAN.
 4. ALL COLLARS, PERS AND WALLS SHALL BE CENTERED ON FOOTINGS. (UNO)
 5. ALL ANCHOR BOLTS SHALL BE C-90 HOT-DIPPED GALVANIZED.
 6. BOTTOM OF COLUMN BASE PLATE ELEVATIONS TO BE 104'-1" (UNO) (REF. SECT. 6/S2.2)
 7. REFER TO DRAWING S01 FOR GENERAL NOTES, ABBREVIATIONS & STANDARD SYMBOLS.

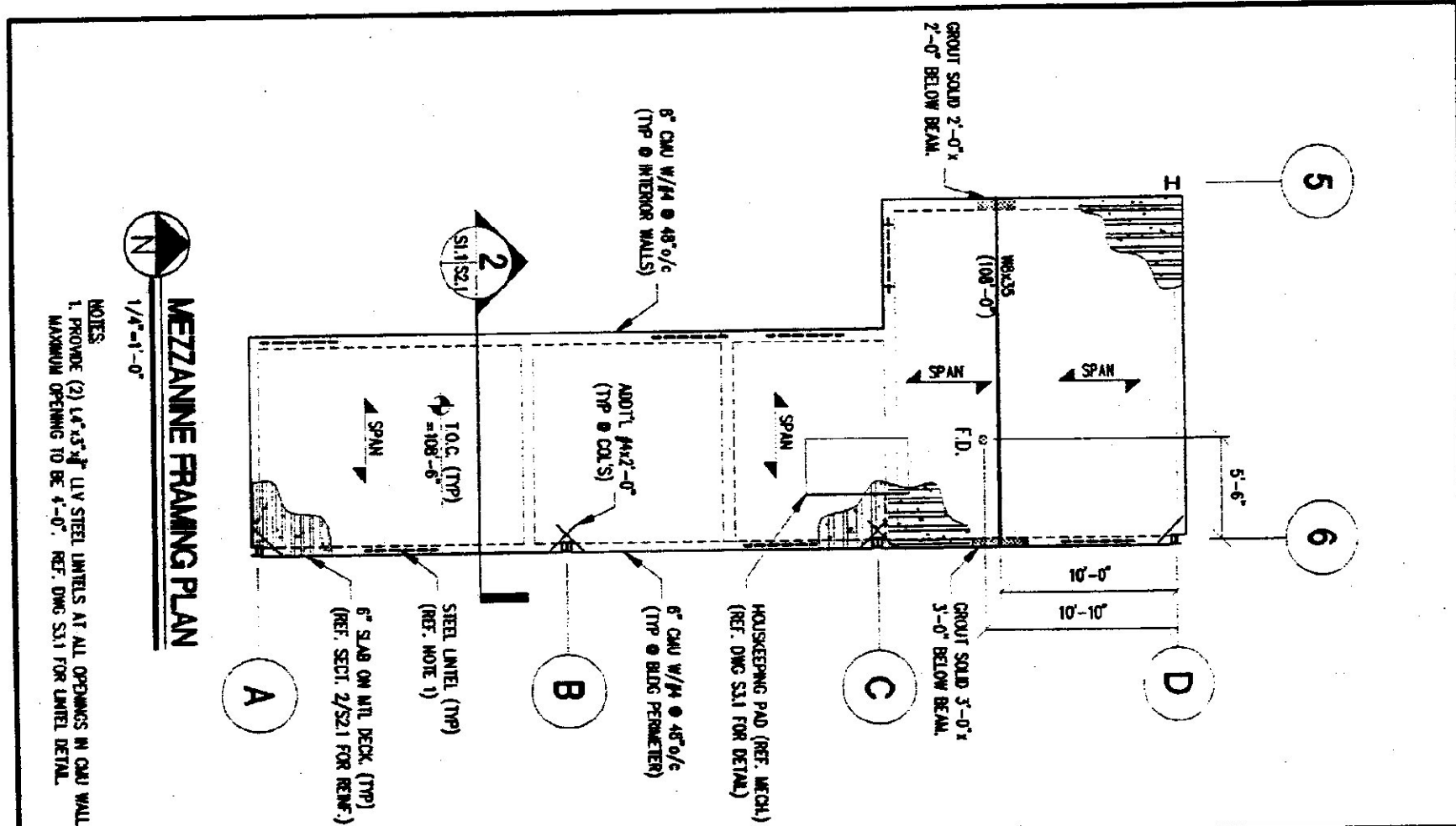

MEZZANINE FRAMING PLAN
1/4"=1'-0"

NOTES:

1. PROVIDE (2) 1/4" X 3/4" LIVE STEEL ANCHORS AT ALL SPACES IN COL. WALL. ANCHOR STRIPS TO BE 4'-0" LONG. SEE S01 FOR ANCHOR DETAIL.

S11	STATE OF VERMONT READSBORO HIGHWAY GARAGE PROJECT READSBORO, VERMONT	Hallam Engineering <small>A Division of Hallam Associates, Inc. 60 Ferris St., Suite 300 So. Burlington, Vermont 05403 (802) 658-4891</small>	The Design Studio of LineSync Architecture <small>14 Castle Hill Wilmington Vermont 05363 9745 USA v.802.464.2526 / hc.2428 www.LineSync.com</small>	<table border="1"> <thead> <tr> <th>No.</th> <th>DATE</th> <th>REVISION</th> </tr> </thead> <tbody> <tr> <td>0</td> <td>10/12/01</td> <td>ISSUED FOR CONSTRUCTION</td> </tr> <tr> <td>1</td> <td>2/4/02</td> <td>INCORPORATED OWNER COMMENTS</td> </tr> </tbody> </table>	No.	DATE	REVISION	0	10/12/01	ISSUED FOR CONSTRUCTION	1	2/4/02	INCORPORATED OWNER COMMENTS			
	No.	DATE	REVISION													
0	10/12/01	ISSUED FOR CONSTRUCTION														
1	2/4/02	INCORPORATED OWNER COMMENTS														
FOUNDATION PLAN	<table border="1"> <thead> <tr> <th>DRAWN</th> <th>REVISION</th> </tr> </thead> <tbody> <tr> <td>THH</td> <td>1</td> </tr> </tbody> </table>	DRAWN	REVISION	THH	1	<table border="1"> <thead> <tr> <th>CHECKED</th> <th>DATE</th> </tr> </thead> <tbody> <tr> <td>THH</td> <td>10/12/01</td> </tr> </tbody> </table>	CHECKED	DATE	THH	10/12/01	<table border="1"> <thead> <tr> <th>SCALE</th> <th>Project No.</th> </tr> </thead> <tbody> <tr> <td>AS NOTED</td> <td>11851.000</td> </tr> </tbody> </table>	SCALE	Project No.	AS NOTED	11851.000	
DRAWN	REVISION															
THH	1															
CHECKED	DATE															
THH	10/12/01															
SCALE	Project No.															
AS NOTED	11851.000															

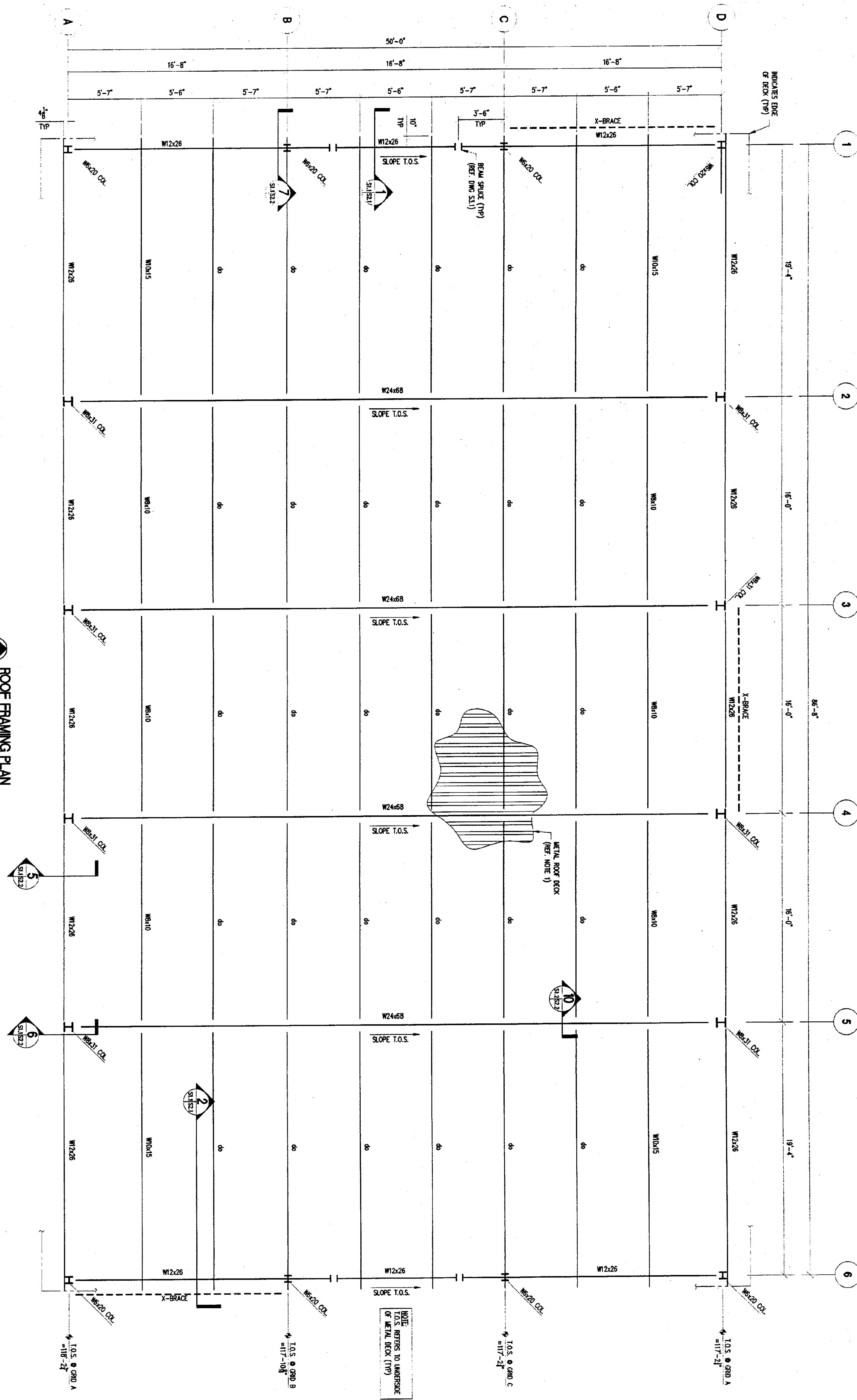



DO NOT ALTER OR REMOVE THIS MARKING FROM ANY PART OF THIS DRAWING.

ROOF FRAMING PLAN

1/4" = 1'-0"

- NOTES:
1. ROOF DECK SHALL BE 1/2" THICK TYPE B 690 GALVANIZED METAL ROOF DECK AS MANUFACTURED BY UNITED STEEL DECK, INC. OR APPROVED EQUIV.
 2. FASTEN METAL ROOF DECK TO STEEL SUPPORTING MEMBERS WITH EPW-21 L15 DECK FASTENERS BY HILT WITH A 36/4 PATTERN. STITCH CONNECTIONS ALONG SIDE LAPS SHALL BE F10 SCREWS WITH (3) SCREWS (MIN) PER SPAN.
 3. TOP OF STEEL FRAMING (UNDERSE OF BEAM) ELEVATION IS AS NOTED ON THE PLAN.
 4. REFER TO DRAWING S0.1 FOR GENERAL NOTES, ABBREVIATIONS & STANDARD SYMBOLS.
 5. COORDINATE ALL ROOF OPENINGS WITH ARCHITECTURAL DRAWINGS.
 6. REFER TO ARCHITECTURAL DRAWINGS FOR ROOF CONSTRUCTION DETAILS.

NOTE: T.O.S. REFERS TO UNDERSE OF METAL DECK (TYP)

<h1 style="font-size: 2em; margin: 0;">S1.2</h1>	STATE OF VERMONT READSBORO HIGHWAY GARAGE PROJECT READSBORO, VERMONT	 A Division of Hallam Associates, Inc. 60 Parrel St., Suite 300 So. Burlington, Vermont 05403 (802) 658-4091	<table border="1"> <thead> <tr> <th>No.</th> <th>DATE</th> <th>REVISION</th> </tr> </thead> <tbody> <tr> <td>0</td> <td>10/12/01</td> <td>ISSUED FOR CONSTRUCTION</td> </tr> <tr> <td>1</td> <td>2/4/02</td> <td>INCORPORATED OWNER COMMENTS</td> </tr> </tbody> </table>	No.	DATE	REVISION	0	10/12/01	ISSUED FOR CONSTRUCTION	1	2/4/02	INCORPORATED OWNER COMMENTS	
	No.	DATE	REVISION										
0	10/12/01	ISSUED FOR CONSTRUCTION											
1	2/4/02	INCORPORATED OWNER COMMENTS											
ROOF FRAMING PLAN	 The Design Studio of LineSync Architecture 14 Castle Hill Wilmington Vermont 05363 9745 USA v.802.464.2526 / fx.2428 www.LineSync.com												

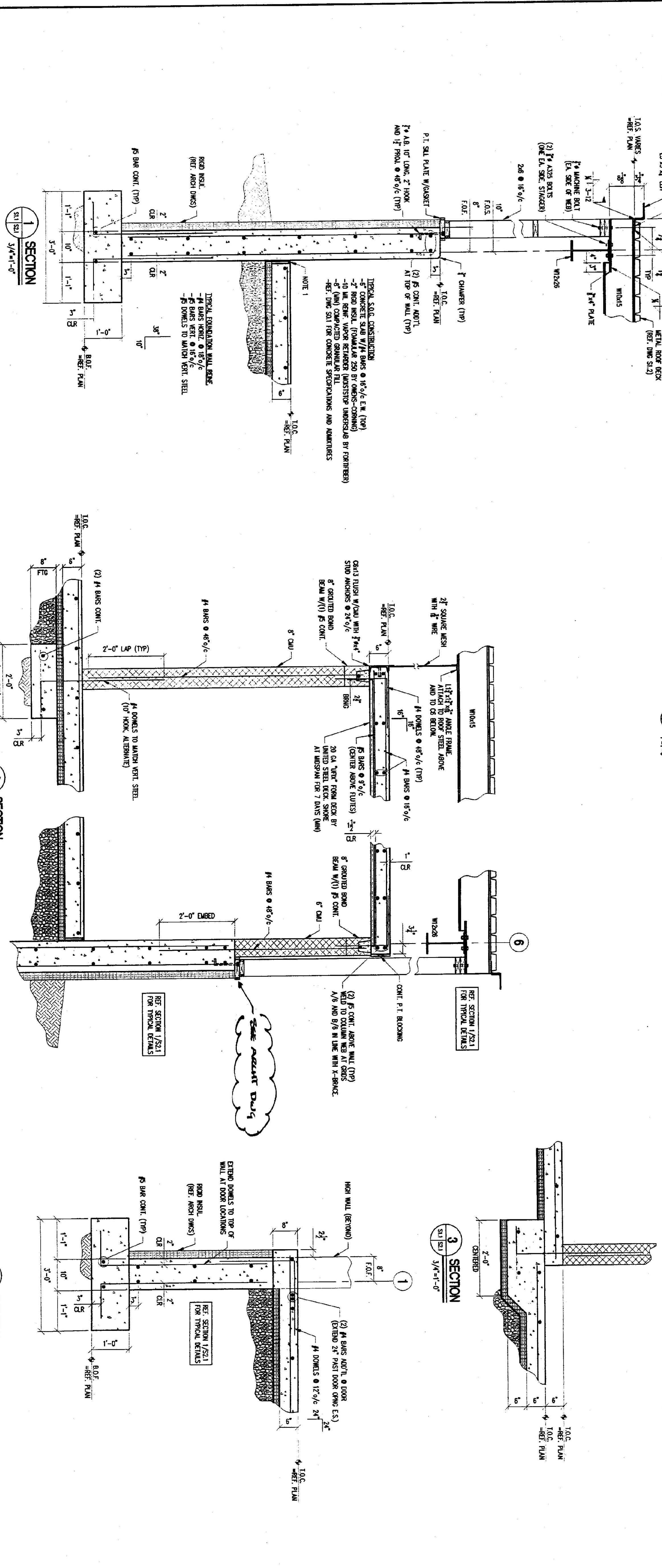
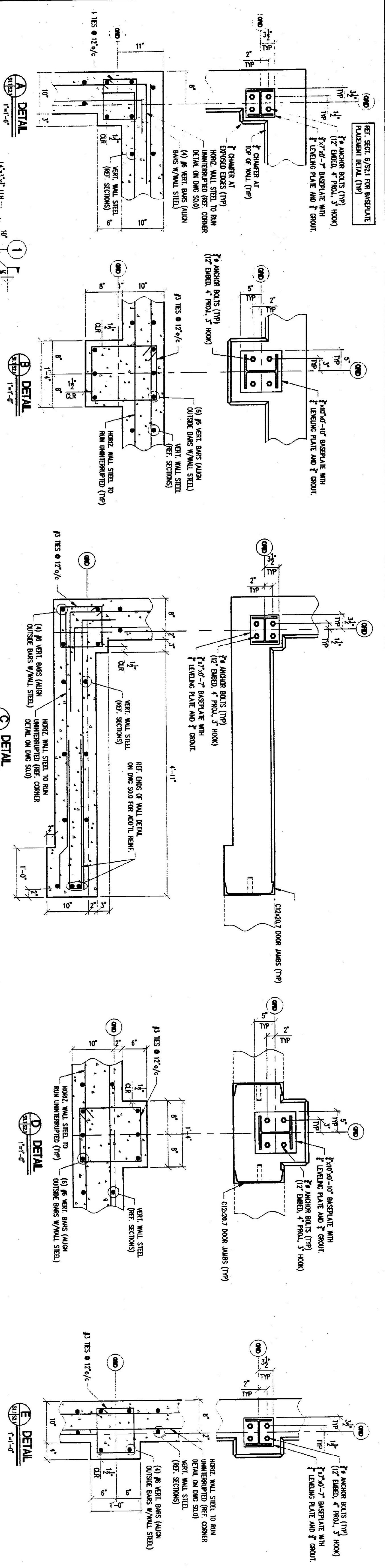

No.	DATE	REVISION
0	10/12/01	ISSUED FOR CONSTRUCTION
1	2/4/02	INCORPORATED OWNER COMMENTS

Halam Engineering
Division of Halam Associates, Inc.
60 Parrott St., Suite 200
So. Burlington, Vermont 05408
(802) 658-4881

The Design Studio of LineSync Architecture
14 Castle Hill Wilmington Vermont 05363 9745 USA
v.802.464.2528 / f.2428 www.LineSync.com

STATE OF VERMONT
READSBORO HIGHWAY GARAGE PROJECT
READSBORO, VERMONT

STRUCTURAL SECTIONS AND DETAILS

DRYAN	REVISION
TPH	1

CHECKED: 10/12/01
DATE: 10/12/01
SCALE: AS NOTED
Project No. 11851.000

S21

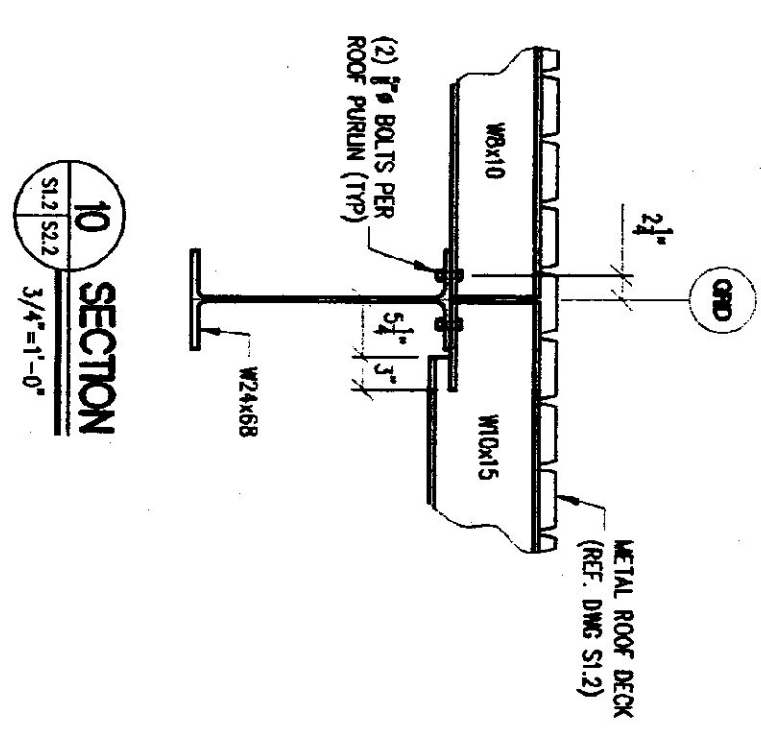
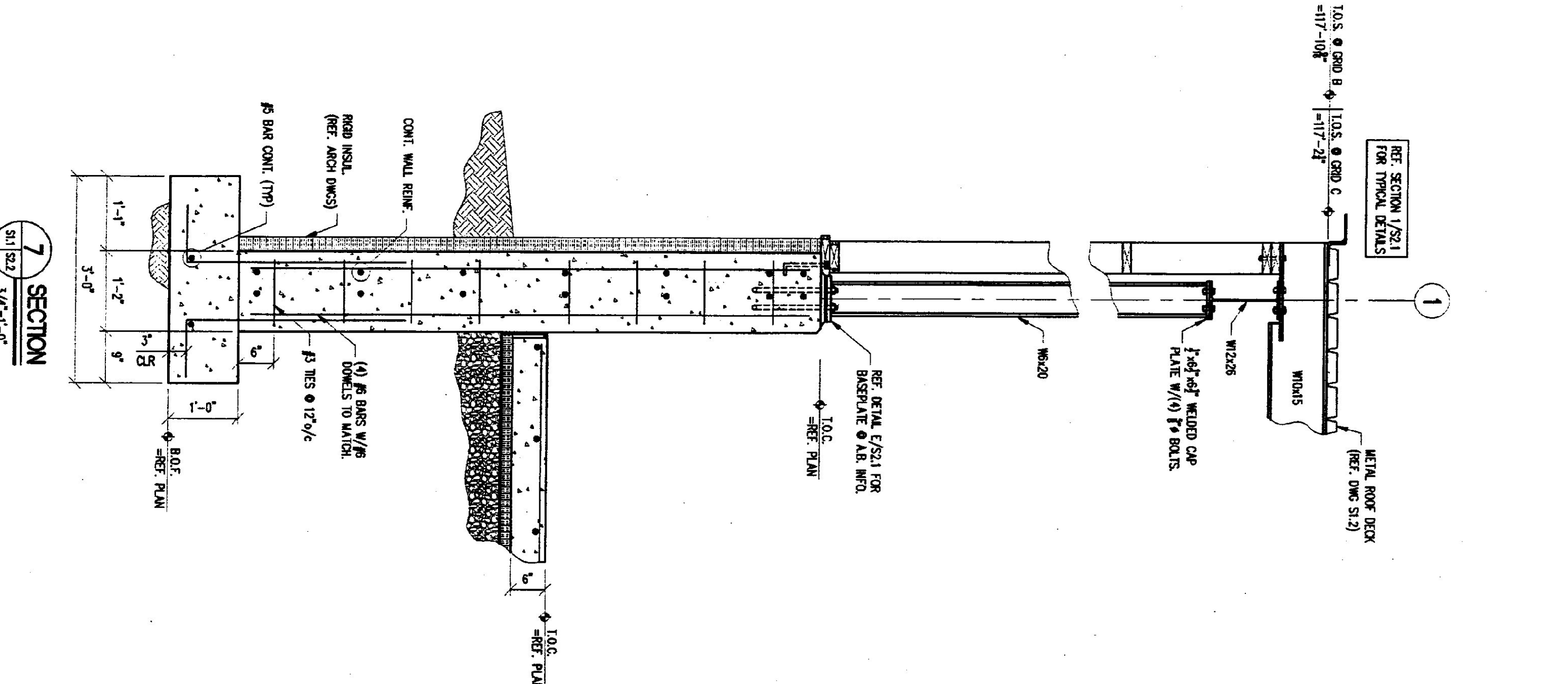
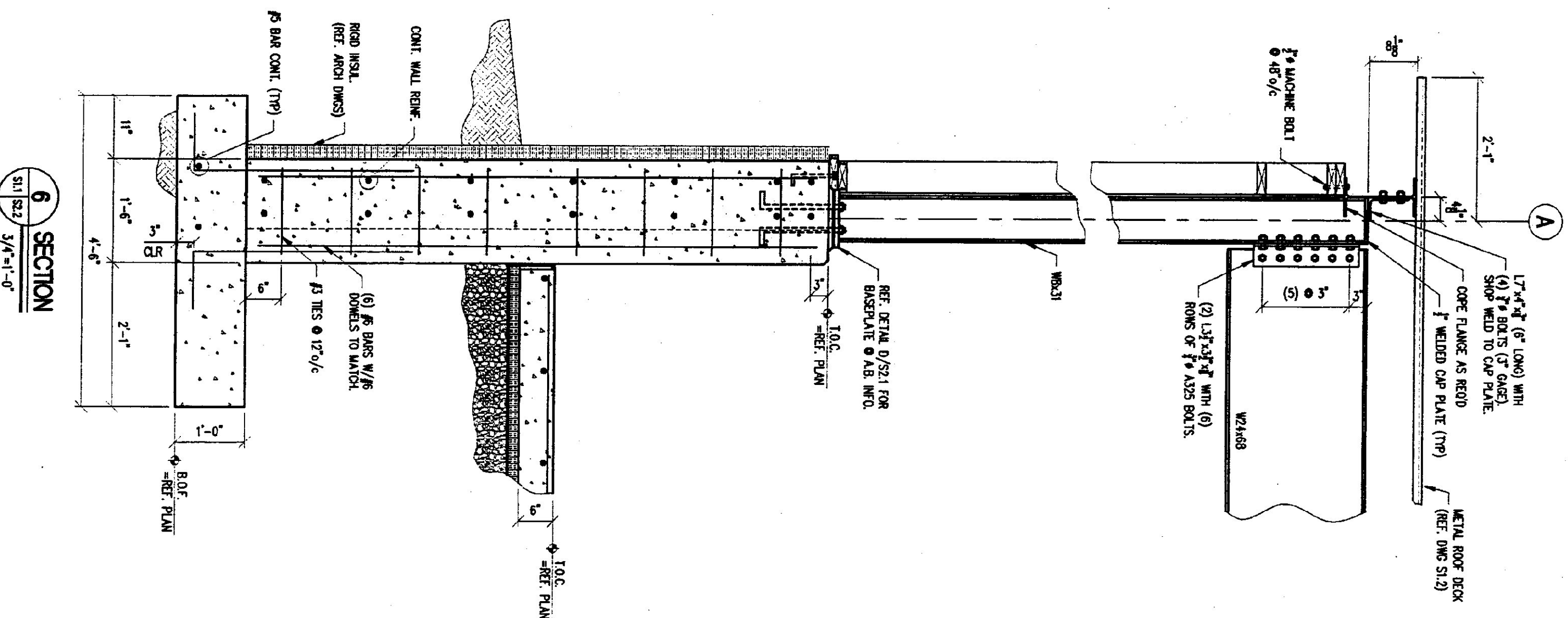
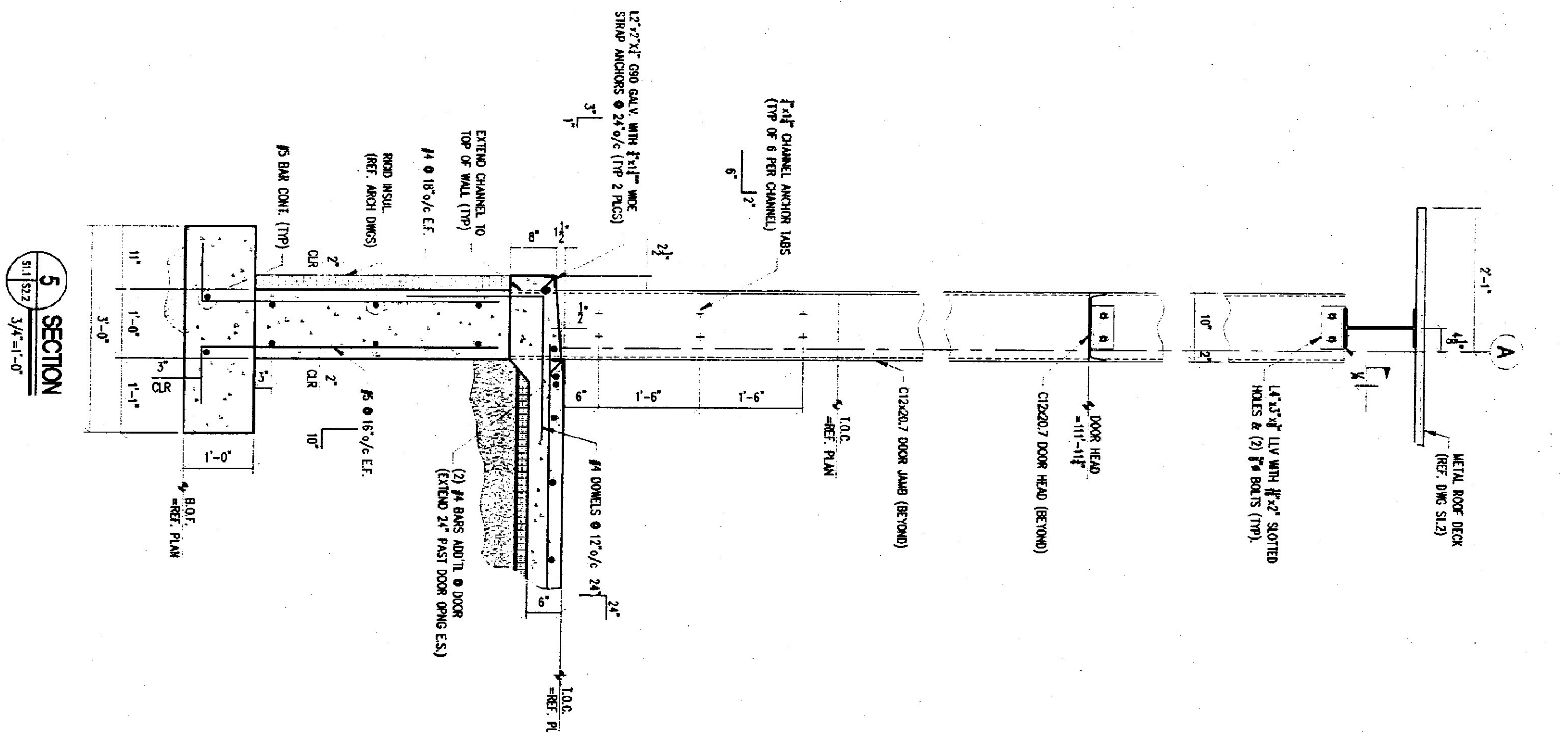

5 SECTION
S11 S22 3/4"=1'-0"

6 SECTION
S11 S22 3/4"=1'-0"

7 SECTION
S11 S22 3/4"=1'-0"

10 SECTION
S12 S22 3/4"=1'-0"

STATE OF VERMONT
READSBORO HIGHWAY GARAGE PROJECT
READSBORO, VERMONT

Hallam Engineering
A Division of Hallam Associates, Inc.
60 Farrell St., Suite 300
So. Burlington, Vermont 05405
(802) 655-4501

The Design Studio of
LineSync Architecture
14 Castle Hill Wilmington Vermont 05363 9745 USA
v.802.464.2526 / fx.2426 www.LineSync.com

No.	DATE	REVISION
0	10/12/01	ISSUED FOR CONSTRUCTION
1	2/4/02	INCORPORATED OWNER COMMENTS

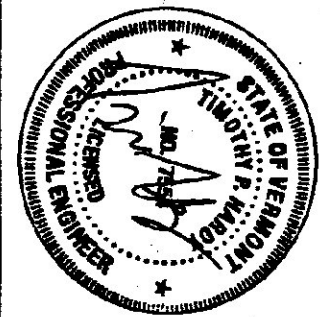

REVISION	DATE	BY
1	10/12/01	TPH

SCALE AS NOTED 11851.000

S2.2

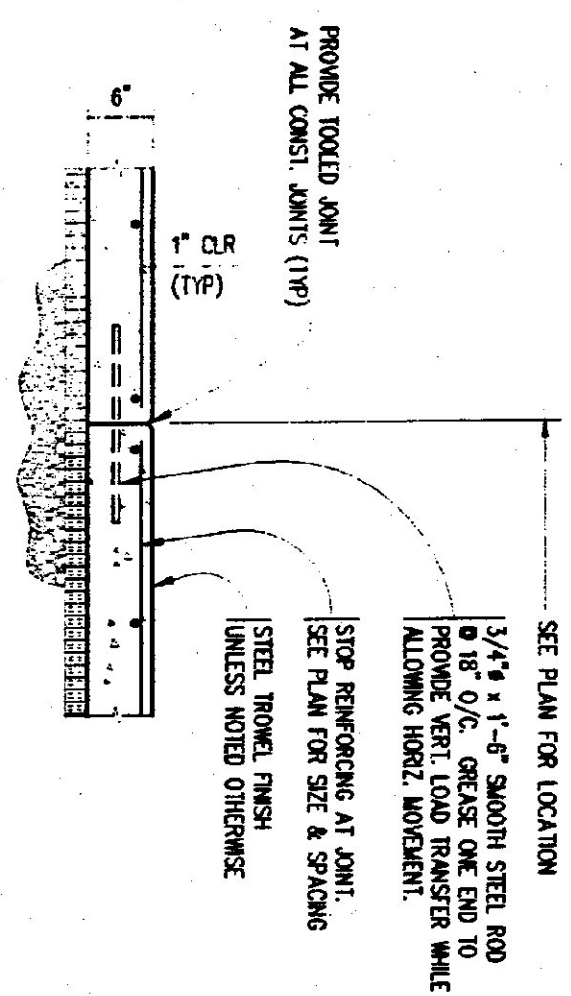

TYPICAL SLAB-ON-GRADE CONSTRUCTION JOINT

NOTE:
1. REFER TO DRAWING S041 FOR CURING SPECIFICATIONS FOR SLAB-ON-GRADE CONSTRUCTION.

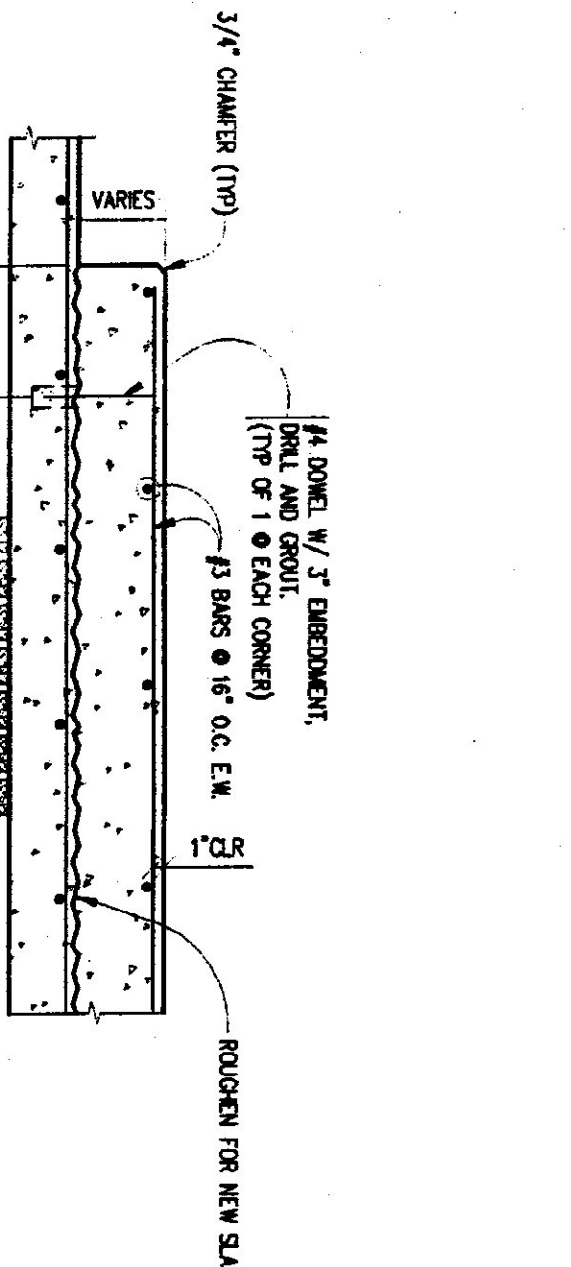

TYPICAL HOUSEKEEPING PAD

NOTE:
1. REFER TO LOCAL DWGS FOR PAD SIZE REQUIREMENTS.
2. DETAIL SIMILAR FOR HOUSEKEEPING PAD LOCATED ON MEZZANINE LEVEL.

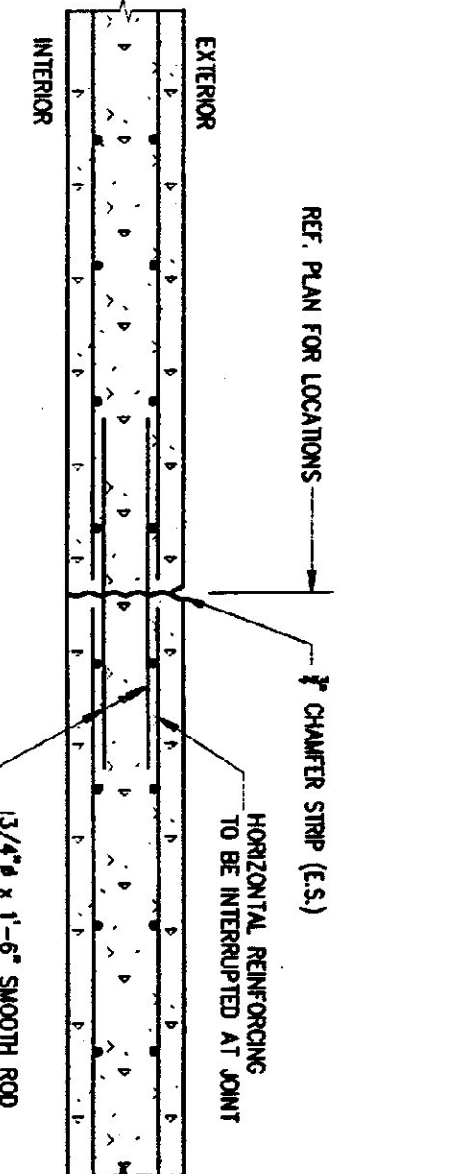

TYPICAL FOUNDATION WALL CONTROL JOINT

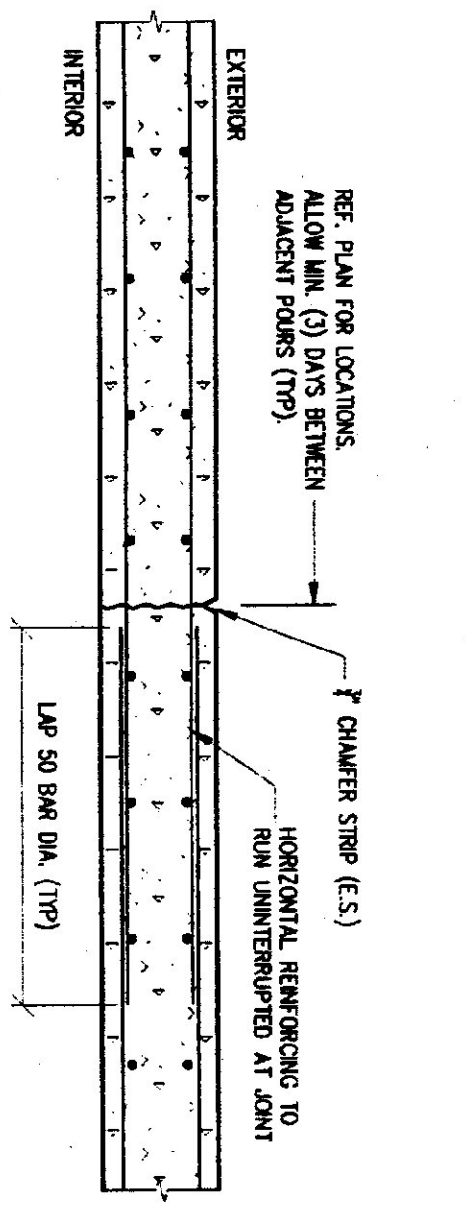

TYPICAL FOUNDATION WALL CONSTRUCTION JOINT

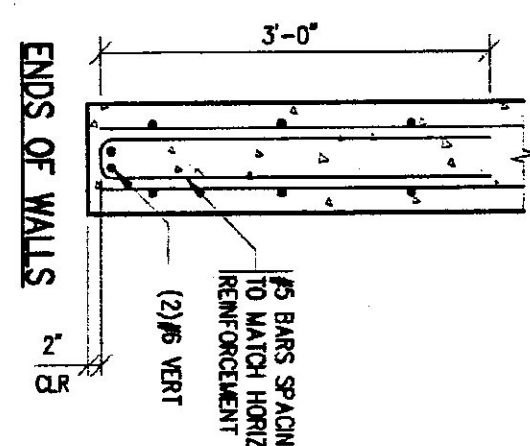
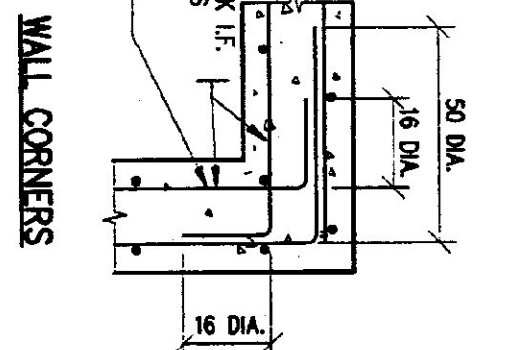
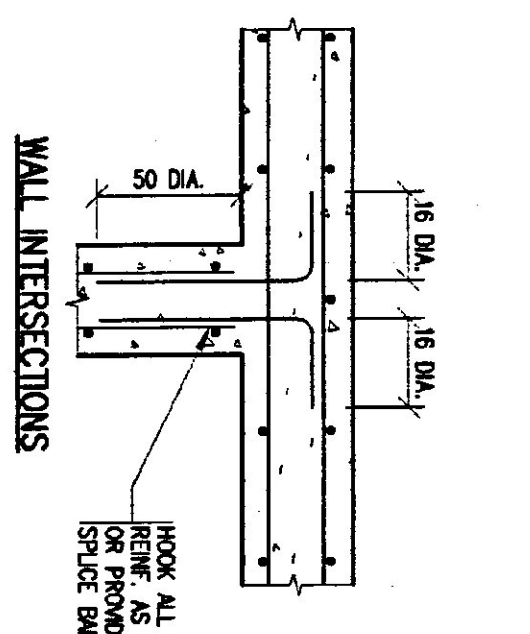

TYPICAL HORIZONTAL WALL REINFORCEMENT

NOTE:
1. CORNER BARS AND SPICE BARS TO BE SAME SIZE AND SPACING AS HORIZONTAL REINFORCEMENT.
2. DETAILS SIMILAR FOR WALLS WITH (1) LAYER OF REIN.

TYPICAL SLAB-ON-GRADE SAWCUT JOINT

NOTE:
1. DETAILS SIMILAR TO SLAB-ON-GRADE CONSTRUCTION.
2. IT IS IMPORTANT TO SAWCUT THE SLAB AS SOON AS SCHEDULE INSTALLATION OF SEALANT AFTER SLAB IS A MINIMUM OF 45 DAYS OLD.

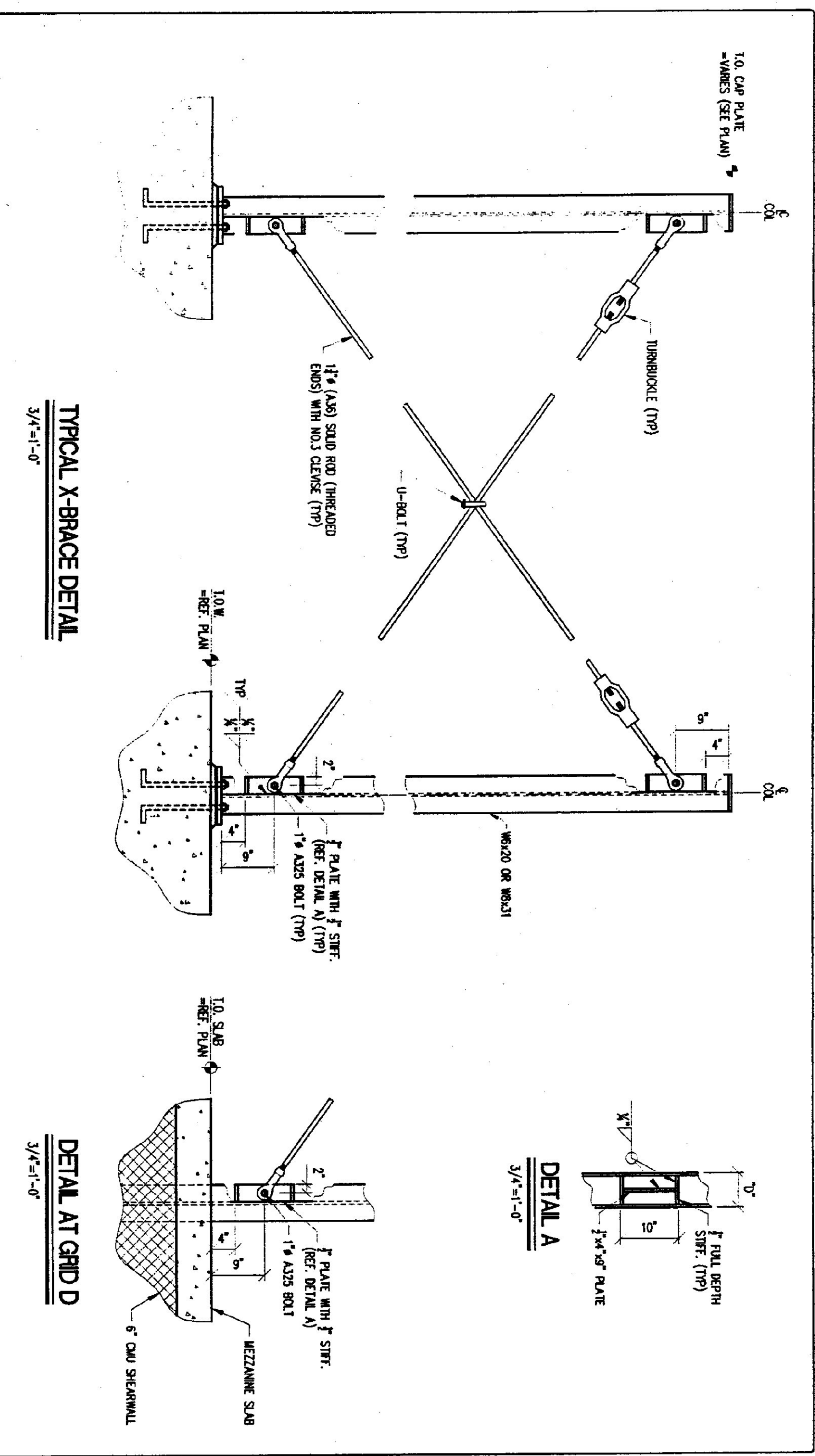
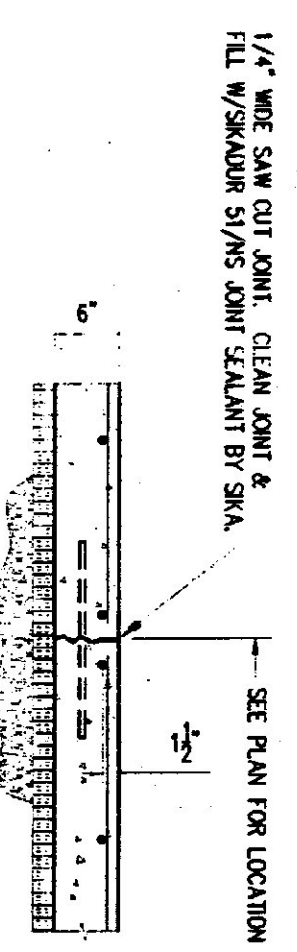

TYPICAL X-BRACE DETAIL

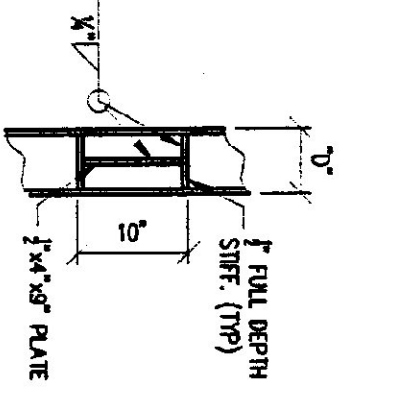

DETAIL A

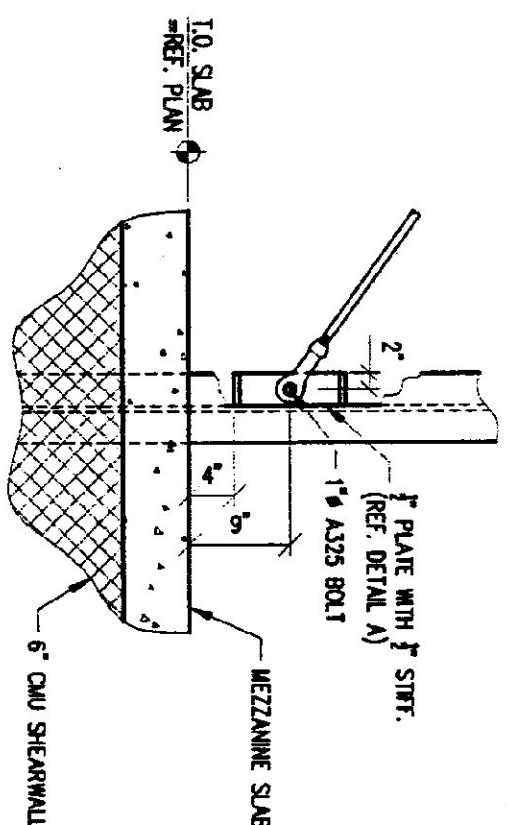

DETAIL AT GRID D

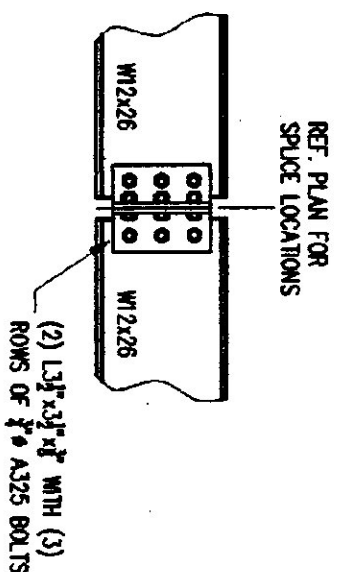

TYPICAL BEAM SPICE DETAIL

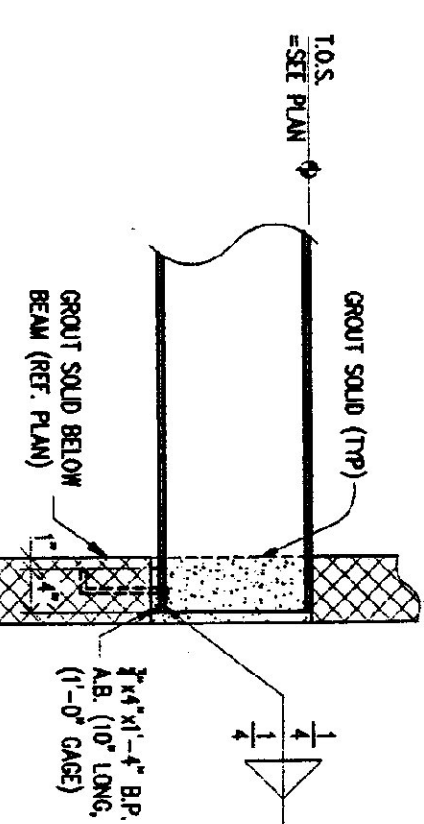

STEEL BEAM BEARING ON CMU

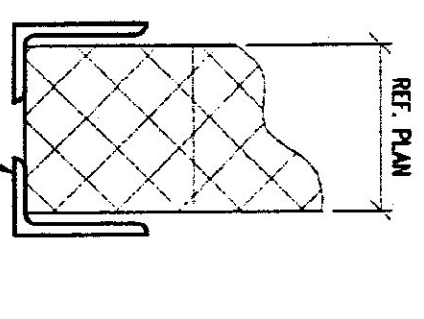

TYPICAL STEEL LINTEL DETAIL

BID ALTERANTE #1

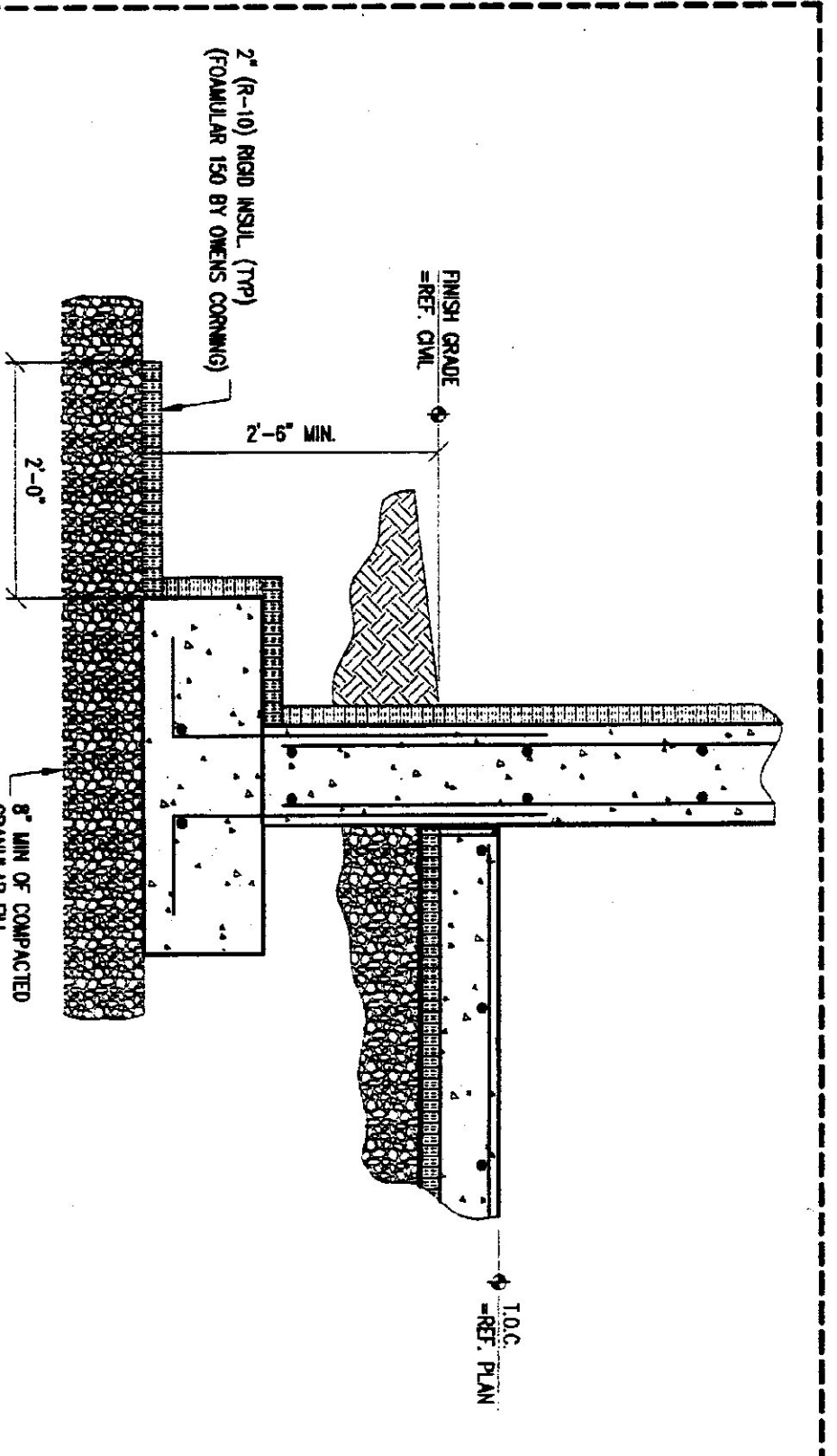

TYPICAL FROST PROTECTED SHALLOW FOUNDATION (F.P.S.F.) DETAIL

NOTE:
1. ALL OTHER FOUNDATION DETAILS (IE. FOOTINGS, WALLS, REIN., ETC) WILL REMAIN THE SAME.



No.	DATE	REVISION
0	10/12/01	ISSUED FOR CONSTRUCTION
1	2/4/02	INCORPORATED OWNER COMMENTS

Hallam Engineering
A Division of Hallam Associates, Inc.
60 Farrell St. Suite 300
St. Albans, Vermont 05403
(802) 688-4801

The Design Studio of LineSync Architecture
14 Castle Hill Wilmington Vermont 05383 9745 USA
v.802.464.2528 / fx.2428 www.LineSync.com

STATE OF VERMONT
READSBORO HIGHWAY GARAGE PROJECT
READSBORO, VERMONT

STANDARD STRUCTURAL DETAILS

REVISION	DATE
1	10/12/01

S3.1

LIGHTING FIXTURE SCHEDULE

TYPE	MANUFACTURER	CATALOG NUMBER	TYPE	COLOR	MOUNTING VOLTAGE	LUMENS	REMARKS	WATTS
V	REFER TO SALT SHED DRAWINGS FOR FIXTURE TYPE AND STYLE		WALL		120V	(2) 150W PAR 38		300
VA	REFER TO SALT SHED DRAWINGS FOR FIXTURE TYPE AND STYLE		WALL		120V	(1) LIT 500		120
VB	DAY-BRITE	WAL-1505120E	WALL	BLACK	120V	(1) LIT 500		175
VT	GROUND-FINIS	WAL222P	PENDANT	BLACK	120V	100A	W/ GUARD AND GLOBE	100

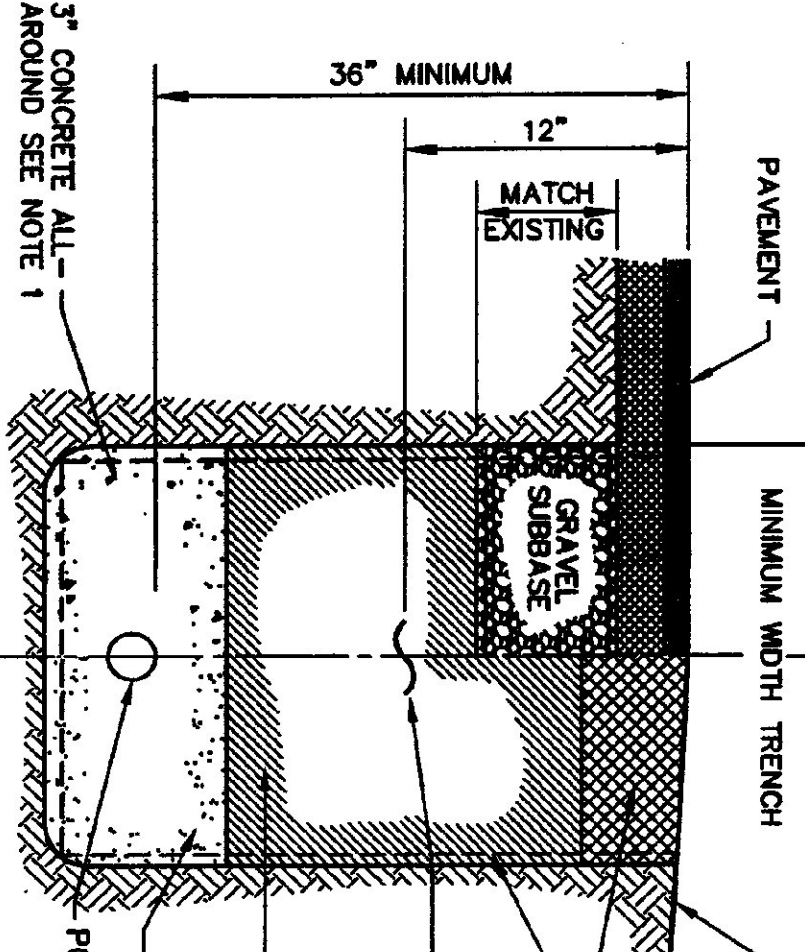
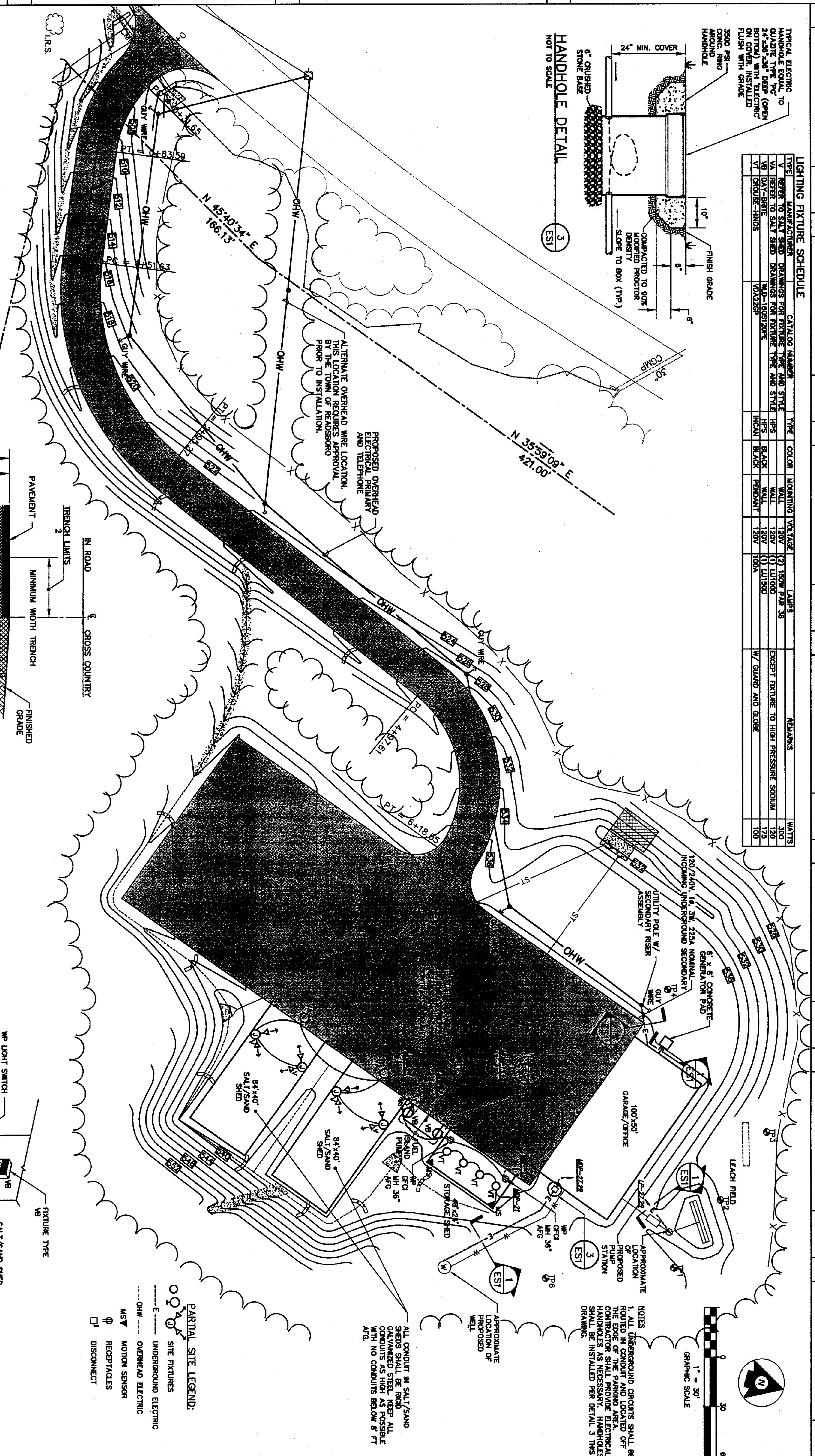
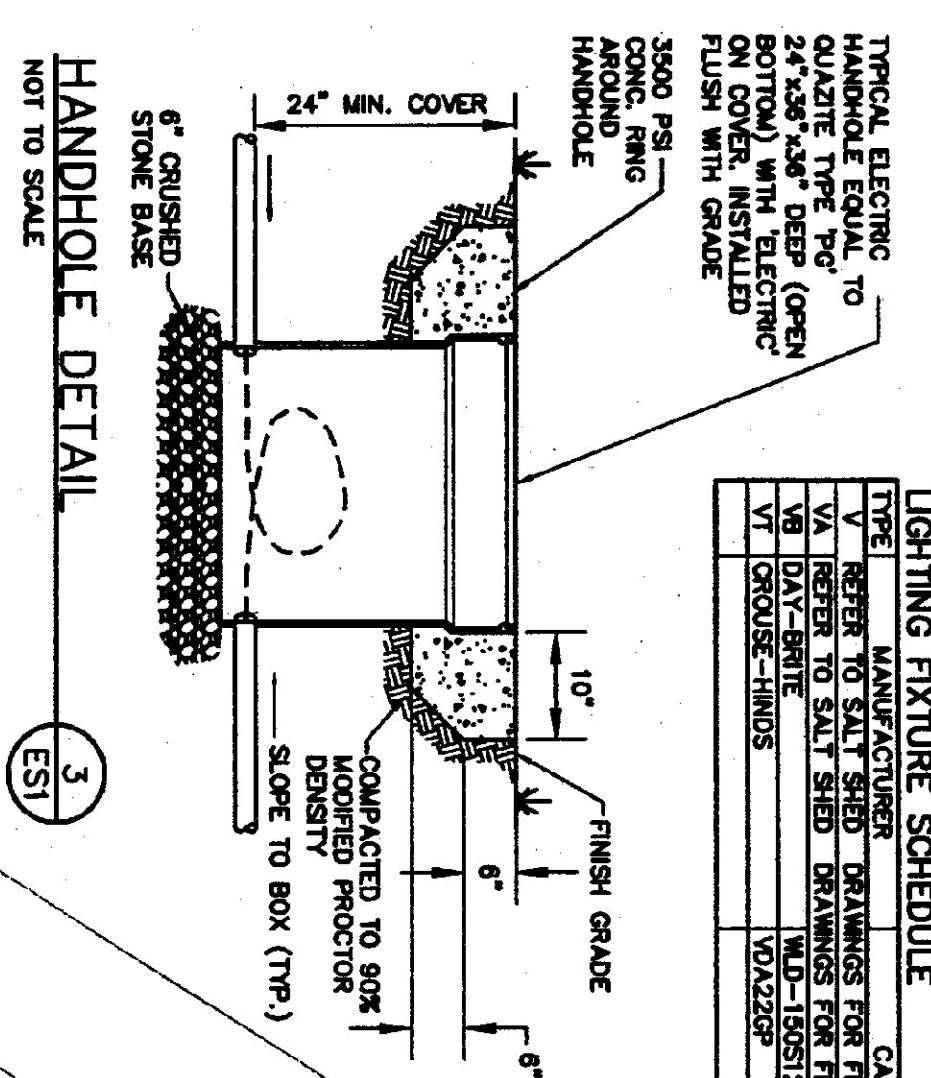

DIG SAFE NOTE:
UTILITIES ARE PLOTTED FROM FIELD LOCATION AND ANY RECORD INFORMATION AVAILABLE, AND SHOULD BE CONSIDERED APPROXIMATE. OTHER UTILITIES MAY EXIST WHICH ARE NOT EVIDENT OR FOR WHICH RECORD INFORMATION IS NOT AVAILABLE. ALL OPERATIONS SHALL BE ACCORDING TO THE STATE OF VERMONT'S REGULATIONS AS AMENDED) MUST CONTACT ALL UTILITY COMPANIES BEFORE EXCAVATING AND DRILLING. ALSO, CALL "DIG SAFE" AT (888)344-7233 [(888)DIG-SAFE].

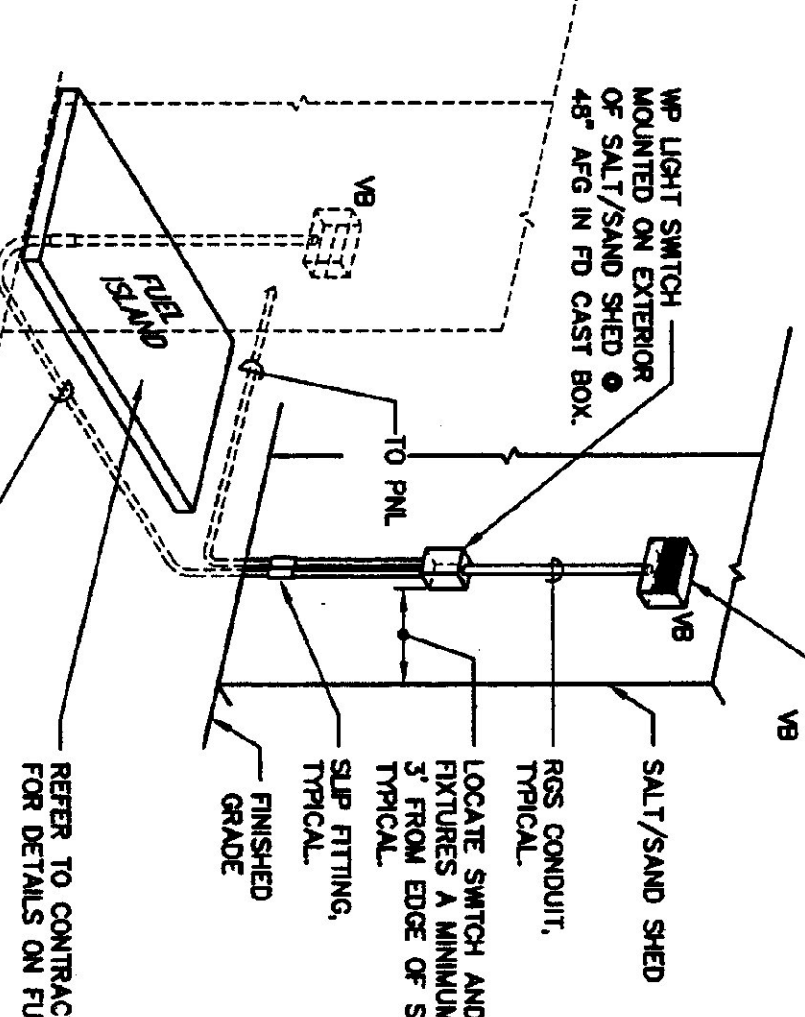

PARTIAL SITE LEGEND:
 ○ SITE FIXTURES
 --- UNDERGROUND ELECTRIC
 --- OHW OVERHEAD ELECTRIC
 --- M.S.W. MOTION SENSOR
 ⊕ RECEPTACLES
 □ DISCONNECT

ALL CONDUIT IN SALT/SAND SHEDS SHALL BE RIGID GALVANIZED STEEL, KEEP ALL CONDUITS AS HIGH AS POSSIBLE WITH NO CONDUITS BELOW 8' FT AFD.

NOTES
 1. ALL UNDERGROUND CIRCUITS SHALL BE ROUTED IN CONDUIT AND LOCATED OFF THE EDGE OF THE PARKING AREA. CONTRACTOR SHALL PROVIDE ELECTRICAL SHIELDING AS NECESSARY. HANDHOLES SHALL BE INSTALLED PER DETAIL 3 THIS DRAWING.

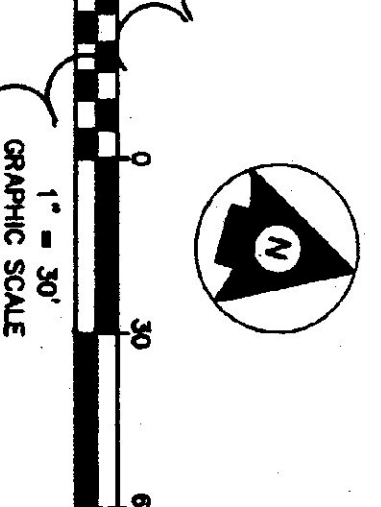

The Design Studio of
Linesync Architecture
 110 South Main Street, Vermont 05519, USA
 TEL: 802.244.4521 FAX: 802.244.4522
 www.linesync.com

DH
Dufresne-Henry
 North Springfield, Vermont
 TEL: (802) 886-2241 FAX: (802) 886-2240
 www.dufresne-henry.com

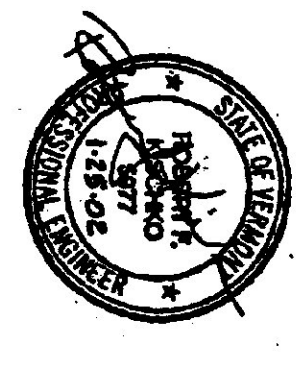

BID DOCUMENTS
 DO NOT REVISE
 January 24, 2002

NO.	REVISION PER VTRAMS COMMENTS	DATE
1	REVISED PER VTRAMS COMMENTS	1/24/2002

READSBORO
 HIGHWAY
 GARAGE PROJECT
 READSBORO, VERMONT

ELECTRICAL SITE PLAN

DATE: 25 OCTOBER 2001
 PROJECT NUMBER: 0000
 SHEET NUMBER: 4
 SHEET TOTAL: 4
ES1

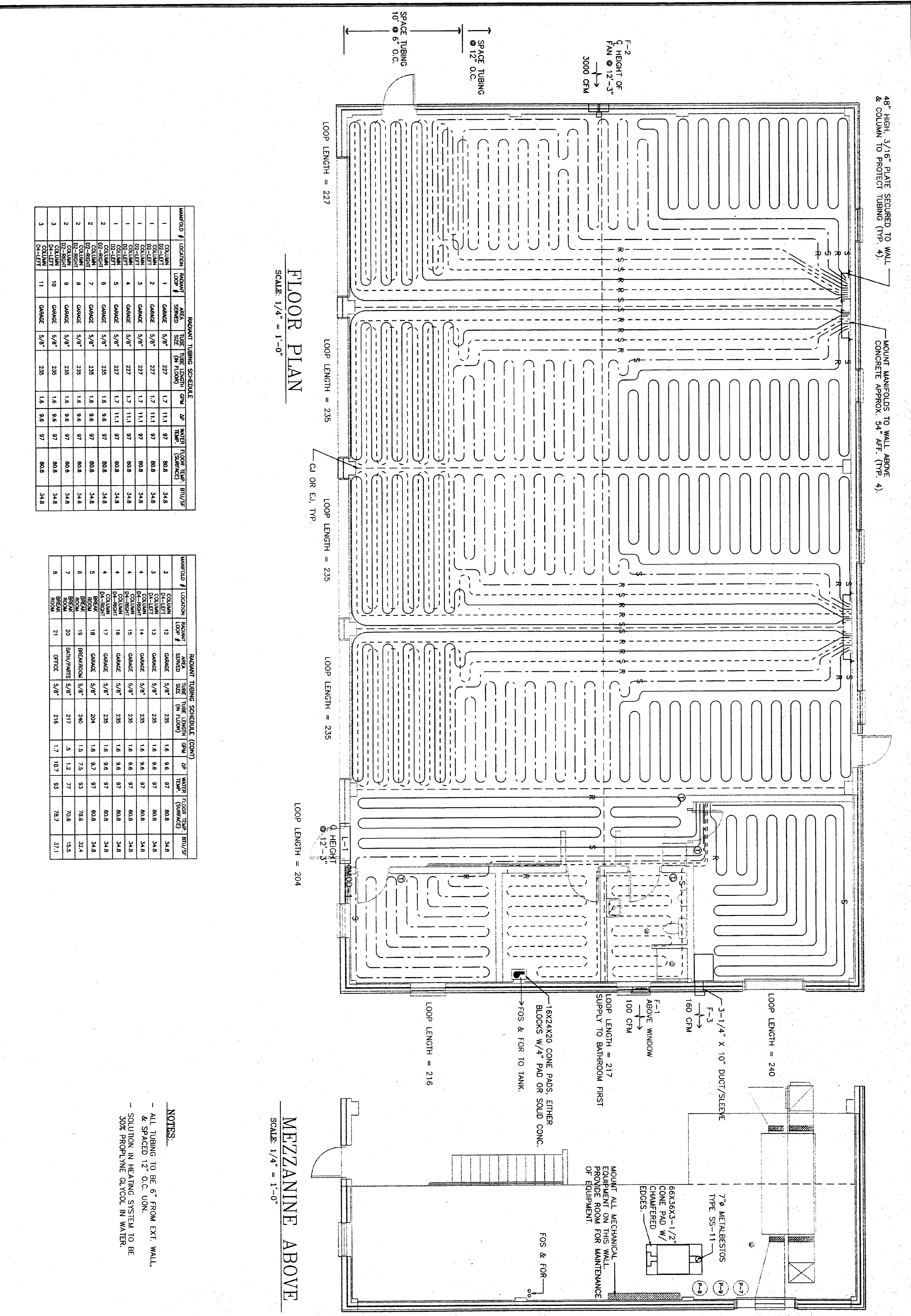

FLOOR PLAN
SCALE: 1/4" = 1'-0"

MEZZANINE ABOVE
SCALE: 1/4" = 1'-0"

MANIFOLD #	LOCATION	RADIANT LOOP #	AREA SERVED	TUBE SIZE (IN FLOOR)	GPW	DP	WATER TEMP. (SURFACE)	FLOOR TEMP. BTU/SF		
1	COLUMN DE-LEFT	1	GARAGE	5/8"	227	1.7	11.1	97	80.8	34.8
1	COLUMN DE-LEFT	2	GARAGE	5/8"	227	1.7	11.1	97	80.8	34.8
1	COLUMN DE-LEFT	3	GARAGE	5/8"	227	1.7	11.1	97	80.8	34.8
1	COLUMN DE-LEFT	4	GARAGE	5/8"	227	1.7	11.1	97	80.8	34.8
1	COLUMN DE-LEFT	5	GARAGE	5/8"	227	1.7	11.1	97	80.8	34.8
2	COLUMN DE-RIGHT	6	GARAGE	5/8"	235	1.6	9.6	97	80.8	34.8
2	COLUMN DE-RIGHT	7	GARAGE	5/8"	235	1.6	9.6	97	80.8	34.8
2	COLUMN DE-RIGHT	8	GARAGE	5/8"	235	1.6	9.6	97	80.8	34.8
2	COLUMN DE-RIGHT	9	GARAGE	5/8"	235	1.6	9.6	97	80.8	34.8
3	COLUMN DE-LEFT	10	GARAGE	5/8"	235	1.6	9.6	97	80.8	34.8
3	COLUMN DE-LEFT	11	GARAGE	5/8"	235	1.6	9.6	97	80.8	34.8

MANIFOLD #	LOCATION	RADIANT LOOP #	AREA SERVED	TUBE SIZE (IN FLOOR)	GPW	DP	WATER TEMP. (SURFACE)	FLOOR TEMP. BTU/SF		
3	COLUMN DE-LEFT	12	GARAGE	5/8"	235	1.6	9.6	97	80.8	34.8
3	COLUMN DE-LEFT	13	GARAGE	5/8"	235	1.6	9.6	97	80.8	34.8
4	COLUMN DE-LEFT	14	GARAGE	3/8"	235	1.6	9.6	97	80.8	34.8
4	COLUMN DE-RIGHT	15	GARAGE	5/8"	235	1.6	9.6	97	80.8	34.8
4	COLUMN DE-RIGHT	16	GARAGE	5/8"	235	1.6	9.6	97	80.8	34.8
4	COLUMN DE-RIGHT	17	GARAGE	5/8"	235	1.6	9.6	97	80.8	34.8
5	BREAK ROOM	18	GARAGE	5/8"	204	1.6	9.7	97	80.8	34.8
6	BREAK ROOM	19	BATH/PARTS	5/8"	240	1.5	7.5	93	78.6	32.4
7	BREAK ROOM	20	BATH/PARTS	5/8"	217	5	1.2	77	70.6	15.5
8	ROOM	21	OFFICE	5/8"	216	1.7	10.7	93	78.7	37.1

NOTES:
- ALL TUBING TO BE 6" FROM EXT. WALL, & SPACED 12" O.C. UN.
- SOLUTION IN HEATING SYSTEM TO BE 30% PROPYLENE GLYCOL IN WATER.

REVISIONS

SCALE: 3/8" = 1'-0"

DATE: AUGUST 2001

DRAWN BY: N. HERSEY

APPR. BY: SOUTHWORTH

READSBORO AOT

FLOOR PLAN

RADIANT HEAT

M-1

OF

READSBORO AOT GARAGE

RADIANT HEAT FLOOR PLAN

READSBORO, VERMONT

STATE OF VERMONT

Department of Buildings and General Services

Agency of Administration

Montpelier, Vermont

SEQUENCE OF CONTROL

1. WHEN OUTDOOR AIR FALLS BELOW 60° (A.O.):
2. BOILER IS ENABLED.
3. TRANSFER PUMP IS ENABLED.
4. CIRCULATORS C-1 AND C-2 ARE STARTED.
5. CIRCULATORS C-3 THROUGH C-7 ARE ENABLED.
6. OPERATING AQUASTAT ON BOILERS TO MAINTAIN BOLLER BETWEEN 150°F AND 170°F.
7. CIRCULATOR C-3 TO BE CONTROLLED BY A WAGOBO DUAL-TEMPERATURE CONTROL. OUTDOOR AIR TEMPERATURE. CIRCULATOR C-3 TO MAINTAIN CALCULATED LOOP SUPPLY SETPOINT. SETPOINT, OFFSET AND RATIO TO BE ADJUSTABLE AT CONTROLLER. SETPOINT TO BE RESET ON OUTDOOR AIR TEMPERATURE BASED ON THE FOLLOWING SCHEDULE:

OUTSIDE AIR TEMP.	SETPOINT
-20°F	57°F
-10°F	57°F
40°F	77°F

8. CIRCULATOR C-4 TO CYCLE ON AND OFF BY THERMOSTAT IN THE OFFICE TO MAINTAIN SETPOINT.
9. CIRCULATOR C-5 TO CYCLE ON AND OFF BY THERMOSTAT IN THE BATHROOM TO MAINTAIN SETPOINT.
10. CIRCULATOR C-6 TO CYCLE ON AND OFF BY THERMOSTAT IN THE BREAK ROOM TO MAINTAIN SETPOINT.
11. AQUASTAT IN DOMESTIC HOT WATER TANK TO CYCLE CIRCULATOR C-7 TO MAINTAIN SETPOINT.
12. FUEL OIL TRANSFER PUMP TO OPERATE WHENEVER BOILER OPERATES. EMERGENCY BOILER SHUT-OFF SWITCH TO SHUT OFF TRANSFER PUMP ALSO.
13. FAN F-1 TO COME ON WITH LIGHT SWITCH, AND OPERATE FOR 5 MINUTES AFTER LIGHT IS TURNED OFF.
14. FAN F-2 TO BE CONTROLLED BY A SPRING WOUND TIMER SWITCH. SEE ELEC. DWG. FOR DETAILS.
15. MOD-1 TO OPEN WHENEVER FAN F-2 OPERATES AND CLOSE WHEN F-2 STOPS.
16. FAN F-3 TO BE CONTROLLED BY SWITCH IN HOOD.

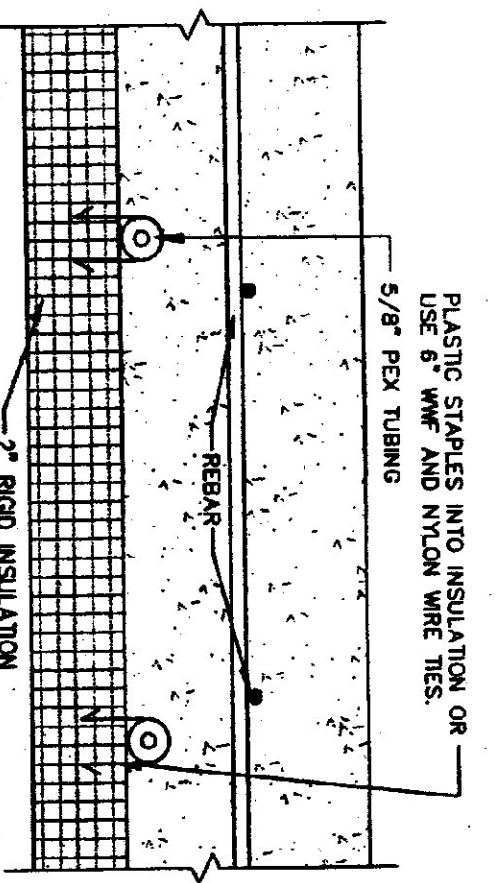

TYPICAL CROSS SECTION
NOT TO SCALE

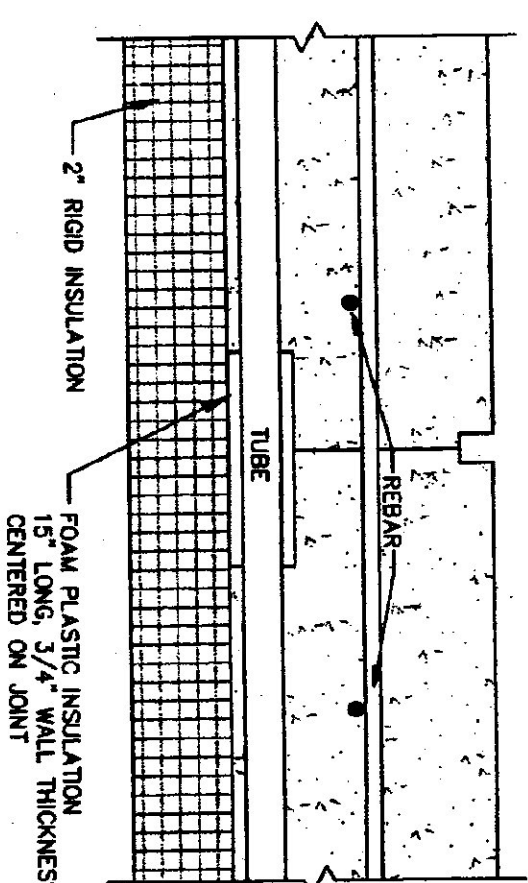

SAW CUT JOINT
NOT TO SCALE

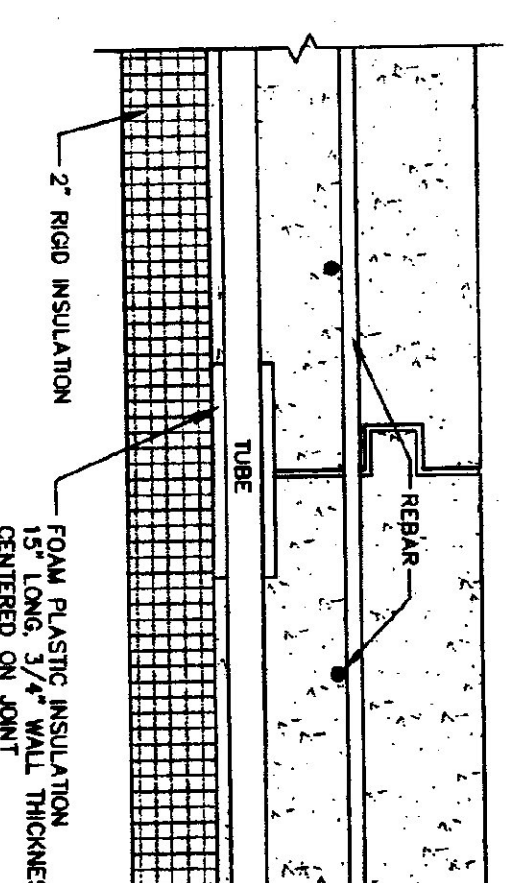

CONSTRUCTION JOINT
NOT TO SCALE

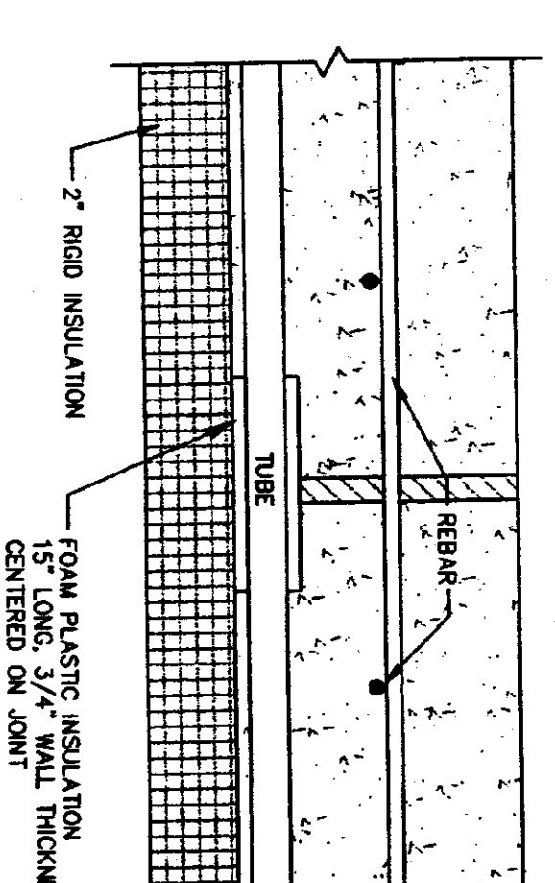

EXPANSION JOINT
NOT TO SCALE

EQUIPMENT SCHEDULE

PLAN SYMBOL	DESCRIPTION	MANUF. & MODEL	CHARACTERISTICS	ELECTRICAL	NOTES
B-1	BOILER	BUERUS G315-5	300,000 BTU GROSS, 30,000 BTU NET, 120V, 40 BRKES, 715 AMPERE	120V/1/60 4.0 A	
XT-1	EXP. TANK	AMTROL SX-90V	44 GALLON TANK, 34 GALLON ACCEPTANCE		
L-1	RELIEF LOWER VENT PRODUCT	PRODUCTS 2750	36" x 36"	120V/1/60	SEAL DIRECT COULDED AIRWAY SYSTEM W/ALUM. N.C.
MOD-1	RELIEF DAMPER VENT PRODUCT	PRODUCTS 5703	36" x 36"	120V/1/60	SEE D.O.C. TANK ASST 2700 7/1600 LABEL SWITCH ASST 22412. HOISTABLE PRESSURE/TEMP. CONTROLLED METEORO PUMP LHM 151-191
GF	GLYCOL FEEDER	LHM		120V/1/60	

CIRCULATOR SCHEDULE

PLAN SYMBOL	SYSTEM	MANUF. & MODEL	G.P.M.	FEET HEAD	H.P.	ELECTRICAL	R.P.M.	NOTES
C-1	MAIN	TACO 0014	25	6.0	1/9	120V/1/60 1.8 A	3250	
C-2	GARAGE ZONE	TACO 0013	30	12.0	1/8	120V/1/60 2.0 A	3250	
C-3	GARAGE INJECTION	TACO 005	4.4	5.5	1/35	120V/1/60 .53 A	3250	
C-4	OFFICE ZONE	TACO 005	1.1	7.3	1/35	120V/1/60 .53 A	3250	
C-5	PARTS/BATHROOM ZONE	TACO 005	0.5	1.2	1/35	120V/1/60 .53 A	3250	
C-6	BREAK ROOM	TACO 005	1.1	7.3	1/35	120V/1/60 .53 A	3250	
C-7	DOMESTIC HOT WATER	TACO 009	6.0	16.0	1/15	120V/1/60 .53 A	3250	ALTERNATE ITEM, SEE SH-V-1
C-8								

FAN SCHEDULE

PLAN SYMBOL	SYSTEM	MANUF. MODEL & TYPE	C.F.M.	S.P. IN.	SONES	FAN RPM	HP.	ELECTRICAL	NOTES
F-1	BATHROOM	GREENHECK SET-8-440-E	100	.125	1050	1/100	120V/1/60	W/WEATHER HOOD, SCREEN & MOD W/ BEARD CIRC.	
F-2	GARAGE VENT	GREENHECK SRS-1L20-4	3000	.125	11.8	764	1/4	120V/1/60	W/WEATHER HOOD, SCREEN & MOD
F-3	RANGE HOOD	NUTONE RL6100	160	.12		1/8	120V/1/60	30" WIDTH W/ EXHAUST WALL CAP	

- NOTES:**
1. TUBING BENDS TO BE RADUSED.
 2. DEVIATION FROM LAYOUT SHALL BE SUBMITTED FROM TUBING MANUFACTURERS AUTHORIZED REPRESENTATIVE.
 3. TUBING INSTALLATION SHALL BE BY MANUFACTURERS AUTHORIZED REPRESENTATIVE.

LEGEND

- ⊕ BALL VALVE FULL PORT, S.S. BALL
- ⊖ BALL VALVE V/P/SE THROTTLE & BRK CAP
- ⊗ SHOWER & BALL VALVE SLOW DOWN
- ⊙ MANUF. VALVE SET @ 93°F
- ⊘ 1000 SOO-C-51
- ⊙ PRESSURE RELIEF VALVE, PIPE TO F.A.F.
- ⊙ THERMOSTAT, MOUNT @ 54" A.F.F.
- ⊙ THERMISTOR
- ⊙ 1000 R10 CHECK
- ⊙ CIRCULATOR
- ⊙ SPRING 1-1/2" AIR SEPARATOR
- ⊙ PRESSURE GAUGE
- ⊙ TORN-AND-REPAIR SMD BALLCHECK VALVE
- ⊙ KEPT OIL LETTER
- ⊙ FUEL OIL THERMOG. PUMP, SINTER BR-1020
- ⊙ FUEL OIL PUMP, FULL PORT, S.S. BALL
- ⊙ SINTER P/W-38
- ⊙ PRINDING VALVE
- ⊙ CHECK VALVE

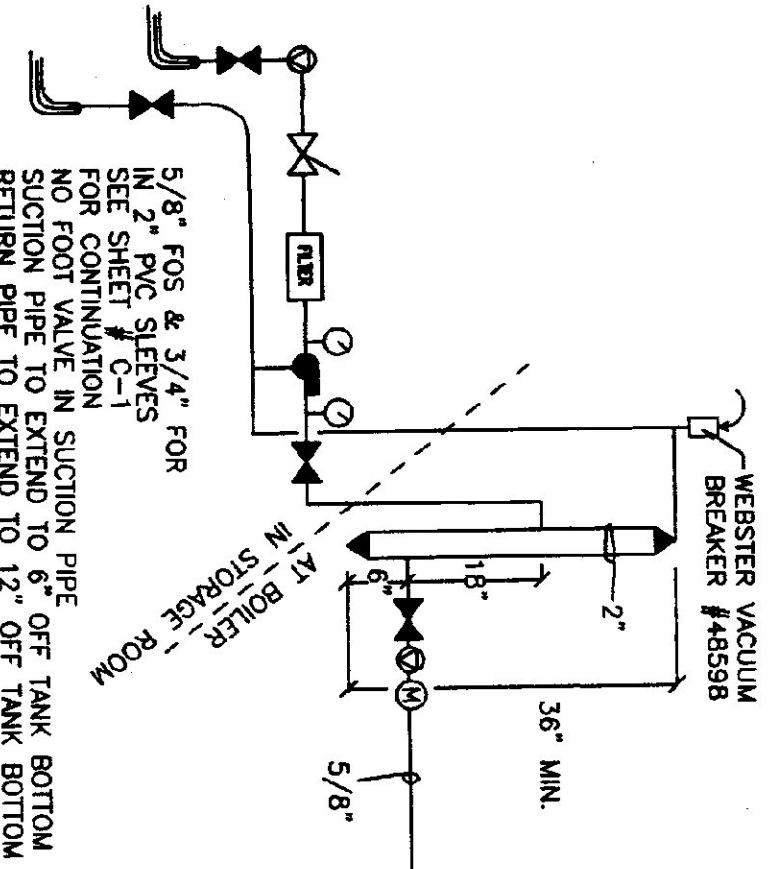

FUEL SUPPLY SCHEMATIC
NOT TO SCALE

HYDRONIC PIPING SCHEMATIC
NOT TO SCALE

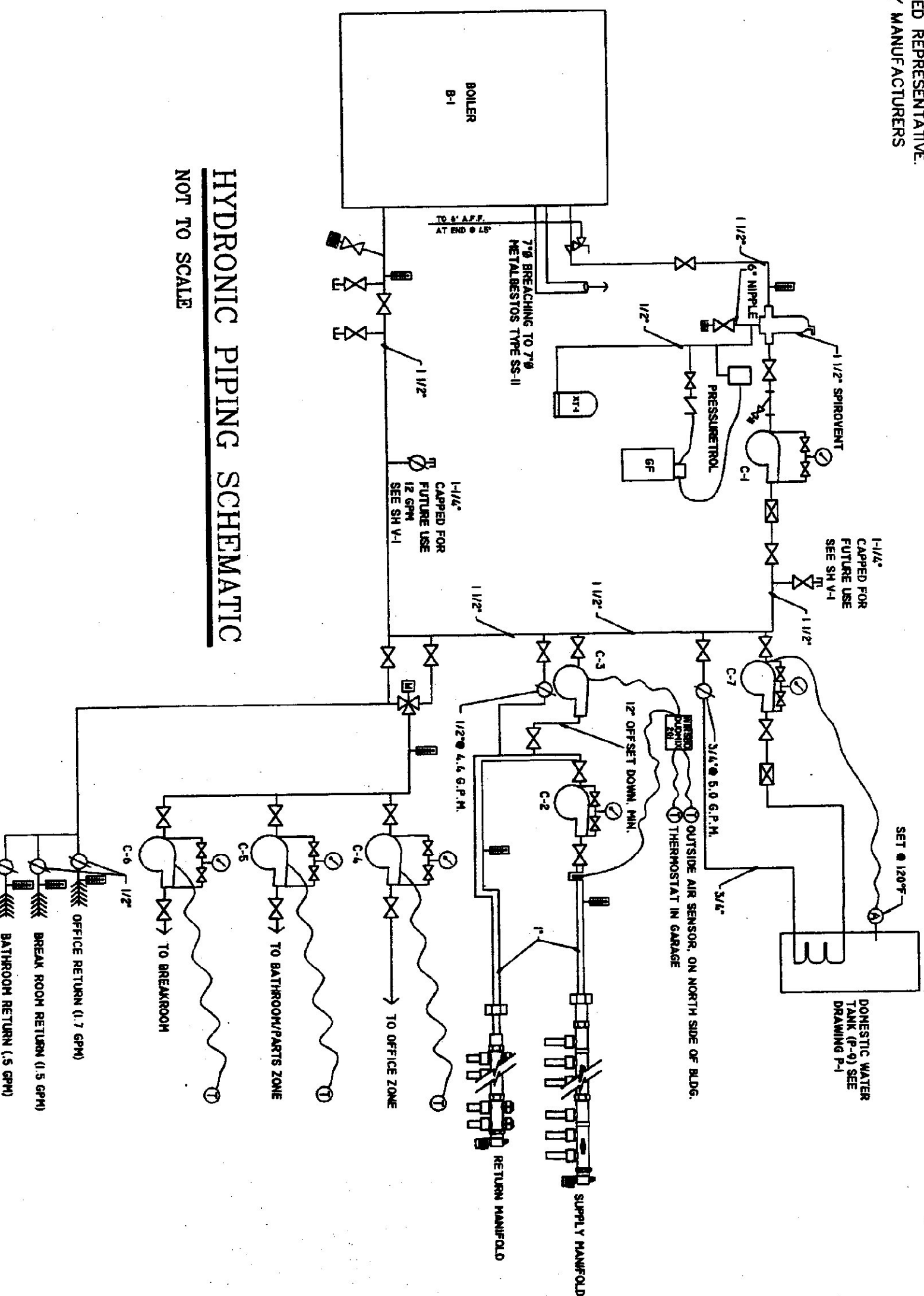

STATE OF VERMONT
Department of Buildings
and General Services
Agency of Administration
Montpelier, Vermont



**READSBORO AOT GARAGE
RADIANT HEATING
DETAILS & SCHEDULES**

READSBORO, VERMONT

REVISIONS

SCALE: AS NOTED
DATE: AUGUST 2001
DRAWN BY: N. HERSEY
APPR. BY: SOUTHWORTH

READSBORO AOT
RADIANT
HEATING
DETAILS

M-2

OF

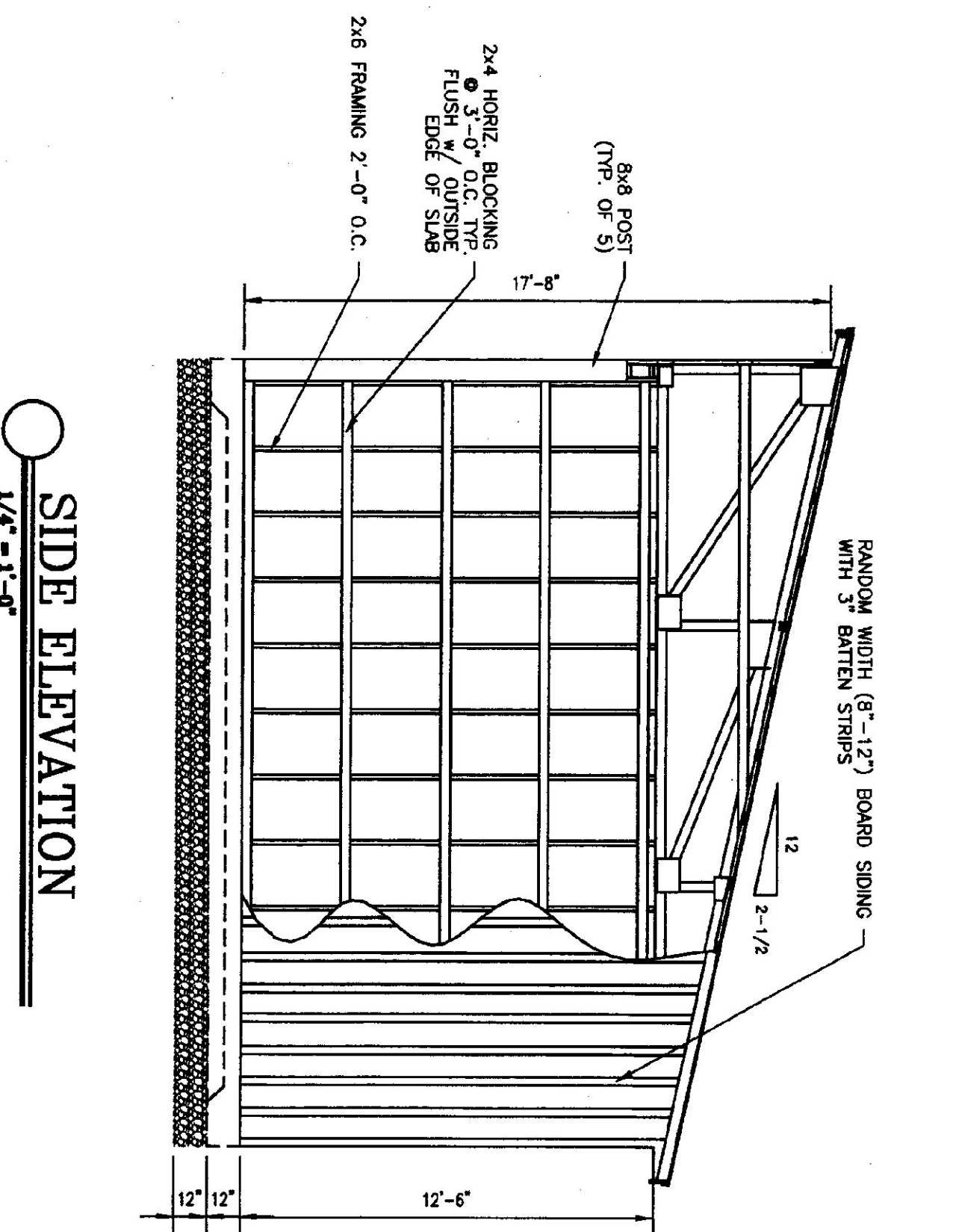
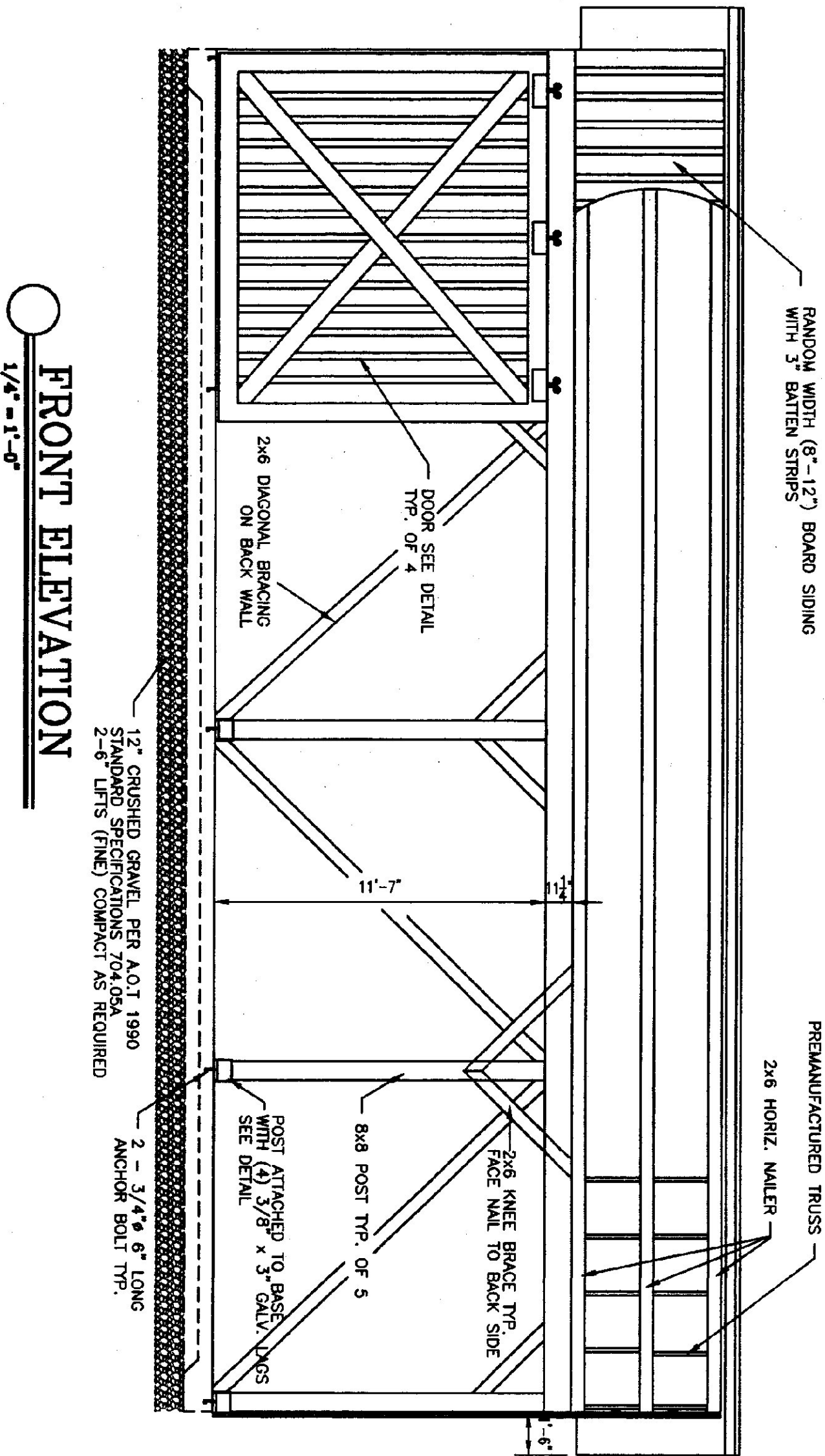
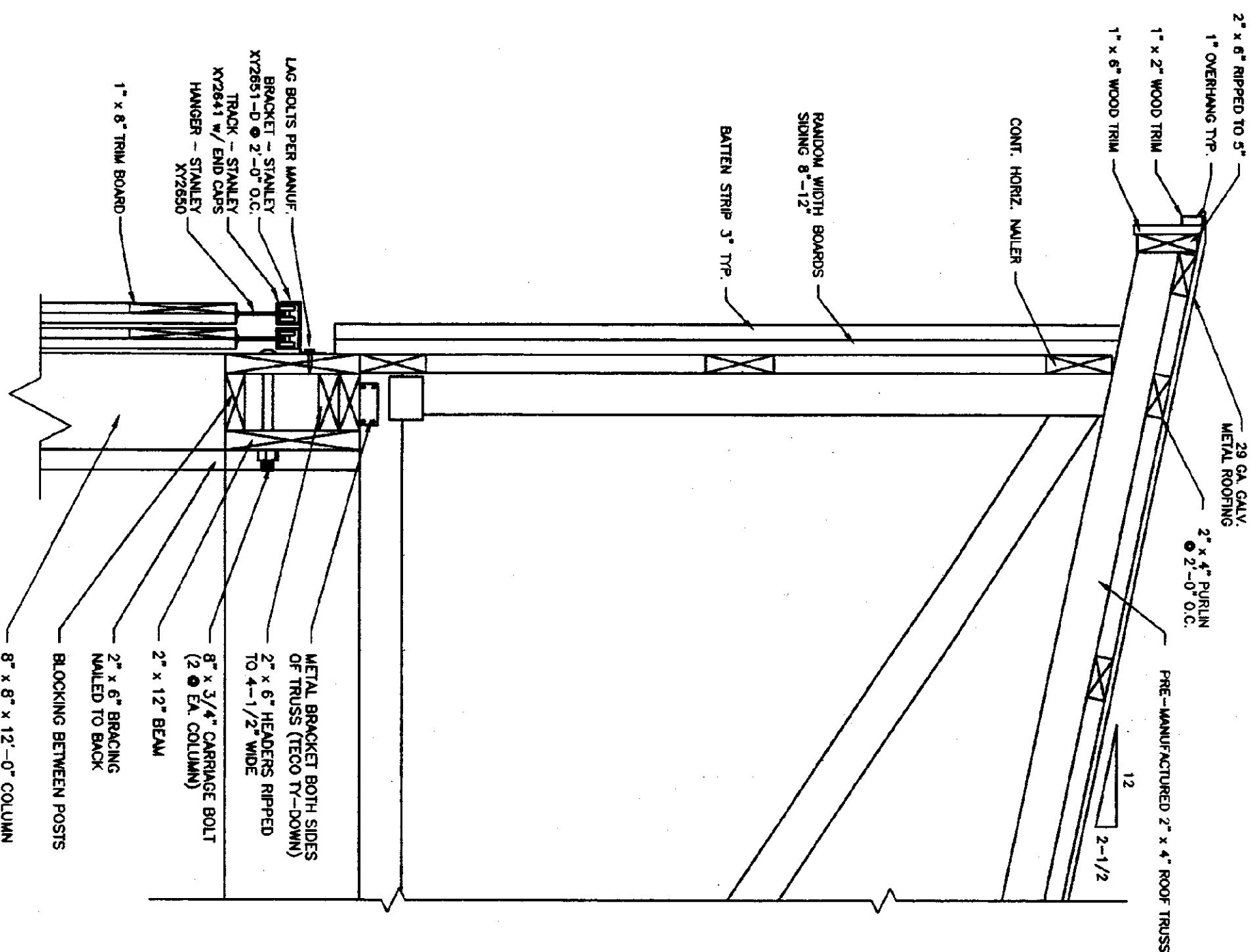
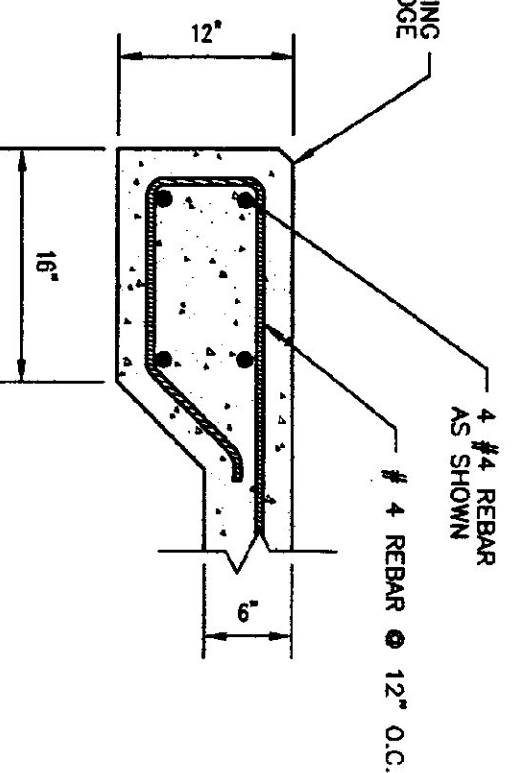
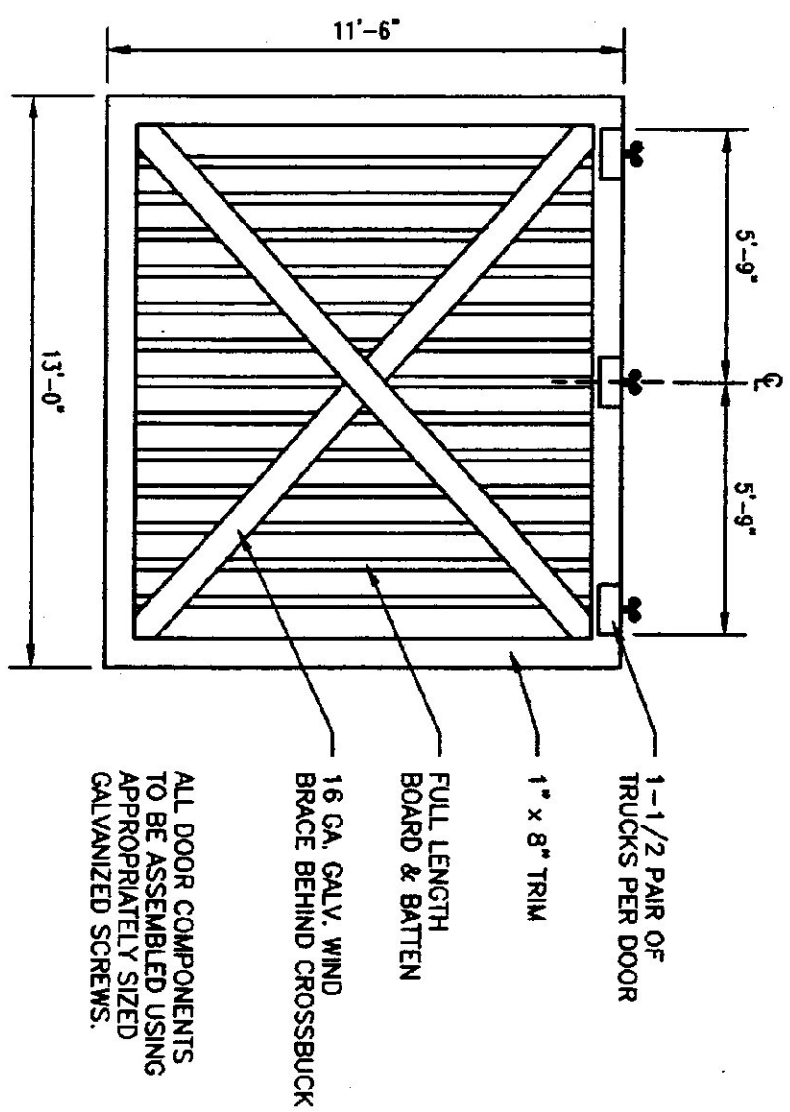
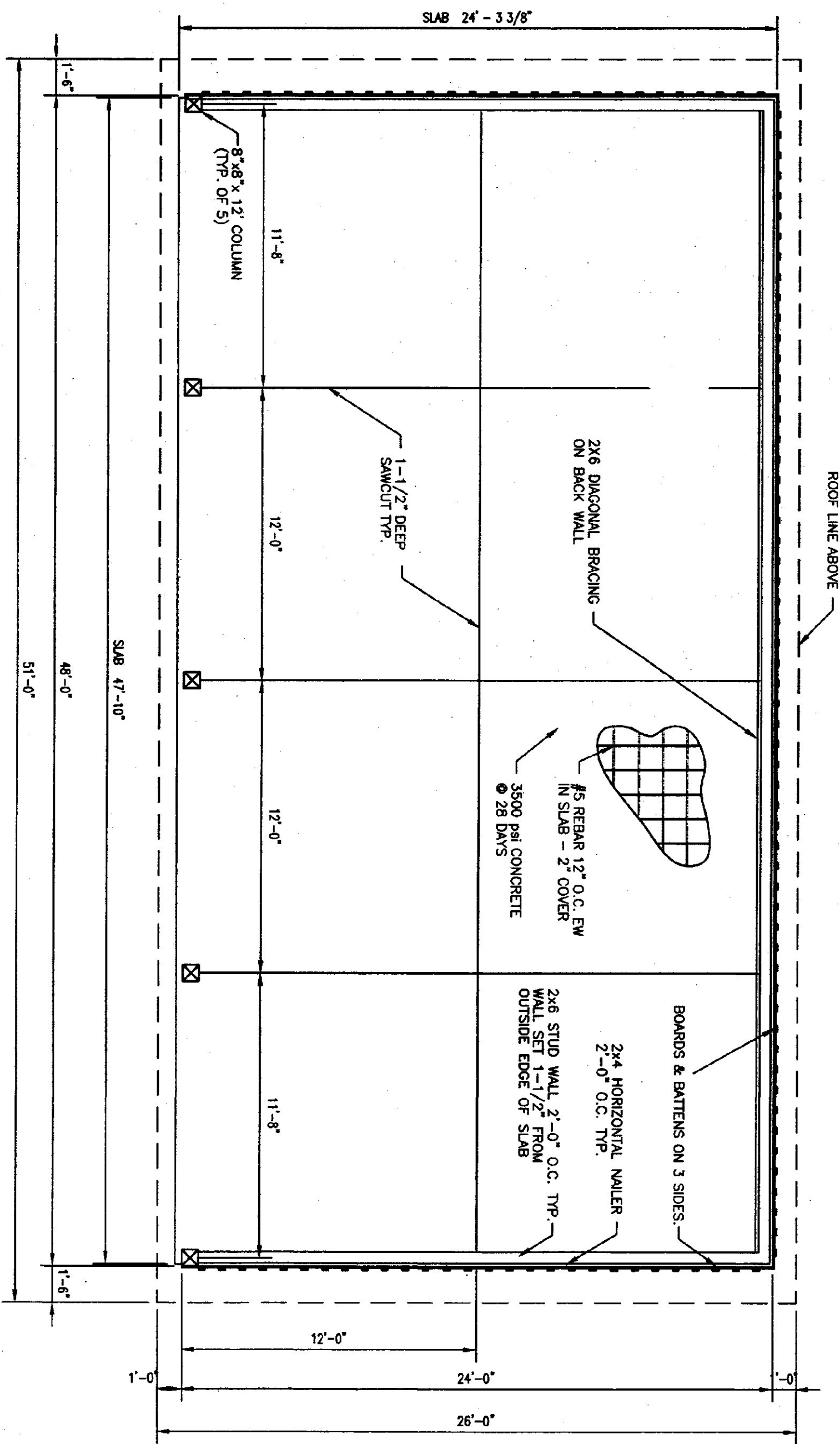

NOTES

TRUSS NOTES:

- TRUSS MANUFACTURER TO PROVIDE DEPT. OF STATE BUILDINGS ENGINEER A SET OF ENGINEERED & STAMPED DRAWINGS FOR APPROVAL PRIOR TO TRUSS MANUFACTURE.
- TRUSS MANUFACTURER TO PROVIDE THE CONTRACTOR WITH ALL NECESSARY INSTRUCTIONS FOR PROPER TRUSS INSTALLATION, ANCHORAGE, BRACING, LIFTING, ETC.
- TRUSS DESIGN LOADS IN ACCORDANCE WITH THE 1987 B.O.C.A. FOR VERMONT.
- MINIMUM LOADS: PER 1987 B.O.C.A. FOR V.T. (60 PSF MIN.)
- WIND - AS CALCULATED FROM TRUSS & ROOF MATERIALS 25 PSF ON BOTTOM CHORD.
- DIAGONAL WIND BRACING PER TRUSS MANUFACTURER.

LUMBER NOTES:

- FRAMING MEMBERS TO BE KILN DRIED CONSTRUCTION GRADE SPRUCE S4S 19% MOISTURE CONTENT.
- PLATES & NAILERS IN CONTACT WITH CONCRETE TO BE CCA 40 TREATED.
- BOARDS & BATTEN SIDING TO BE NATIVE ROUGH SAWN WHITE PINE, SPRUCE, OR EASTERN FIR.
- BOARD SIDING AND BATTEN STRIPS TO BE FULL LENGTH (NO HORIZONTAL JOINTS).
- ALL WALLS TO BE GALVANIZED.

FINISH NOTES:



- ALL BOARDS & BATTENS TO BE STAINED WITH ONE COAT (ALL SURFACES) PRIOR TO INSTALLATION.
- AFTER INSTALLATION EXTERIOR SIDING TO RECEIVE ONE ADDITIONAL COAT OF STAIN.
- STAIN TO BE OLYMPIC OIL BASE SEMI-TRANSPARENT #3535 FLOUGE GREEN OR EQUAL.

REVISIONS	SCALE: AS NOTED
	DATE: FEB. 2002
	DRAWN BY: TJD/KEM
	APPR. BY:

READSBORO

READSBORO A.O.T.
24' x 48' STORAGE BUILDING
PLANS & DETAILS

STATE OF VERMONT
Department of Buildings
and General Services
Agency of Administration
Montpelier, Vermont

SEE SH C-1 FOR CONTINUATION

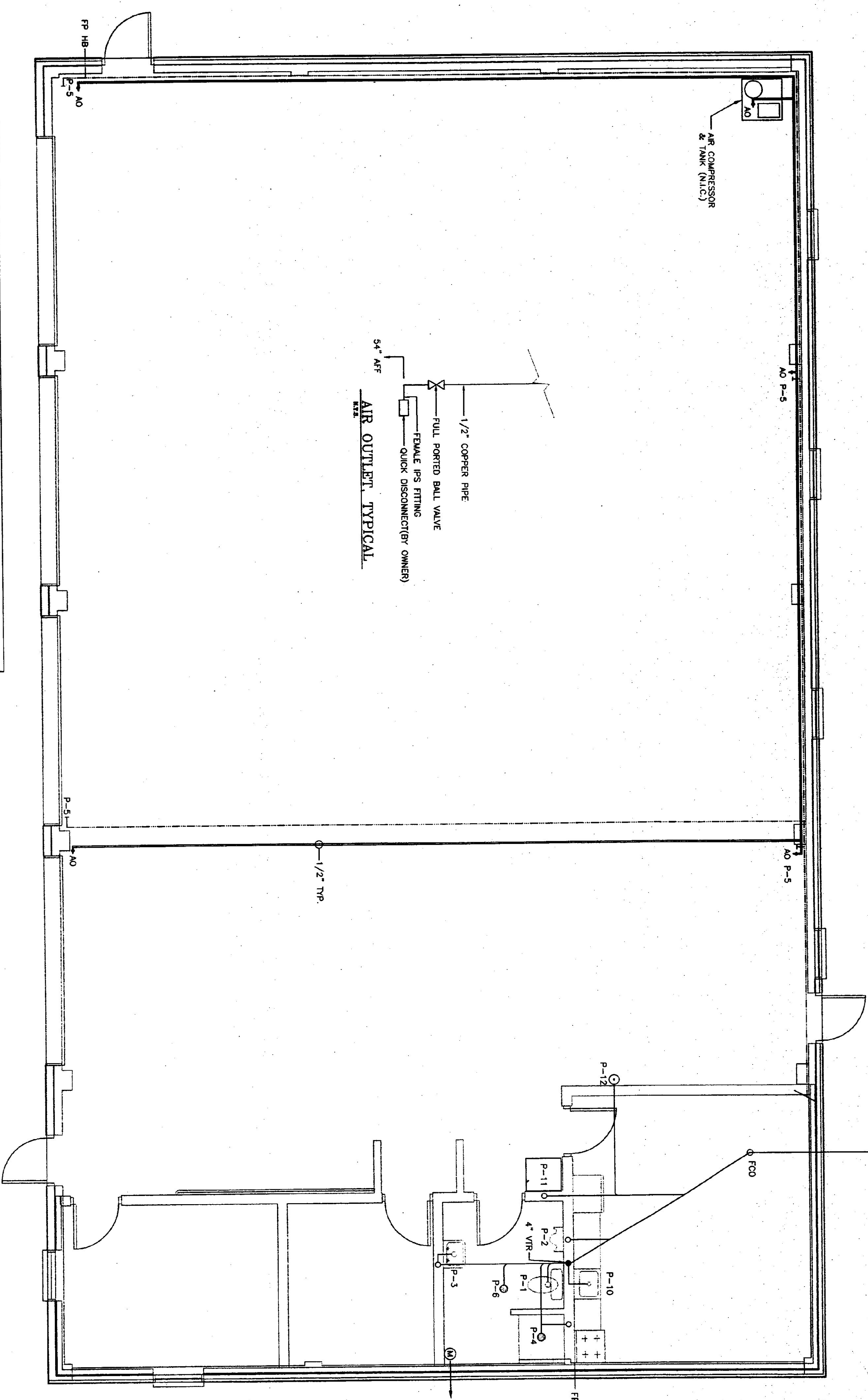

SYMBOL	FIXTURE	DESCRIPTION	NOTES	DNM	VENT	COLD	HOT
P-1	TOILET	AMERICAN STANDARD TOILET # 2184 100 WHITE VITREOUS CHINA, HANDICAP, FLOOR MOUNT, TANK TYPE, PRESSURE ASSISTED, ELONGATED, WATERSEAL, SPHON LET ACTION CLOSE COUPLED, 18" HIGH SEAT TO BE ELONGATED, OPEN FRONT WITH BOLT CAPS, PROVIDE SUPPLY STOP.		4"	4"	1/2"	-
P-2	URINAL	AMERICAN STANDARD WASHROOM # 6501010, 3/4" TOP SPUD, WHITE VITREOUS CHINA, WALL HUNG, WASH OUT URINAL, WITH SLOAN ROVAL 186 FLUSH VALVE & COMBIBLE CARRIER.	MOUNT WITH RIM @ 17" A.F.F.	1/2"	1/2"	1/2"	1/2"
P-3	LAVATORY	AMERICAN STANDARD TOILET # 2021028 WALL HUNG, WHITE VITREOUS CHINA, FRONT OVERFLOW, CENTER SPUD, 15" HIGH SEAT, 18" HIGH SEAT, AMERICAN STANDARD RELIANT # 2385000.	MOUNT WITH RIM @ 34" A.F.F.	1/2"	1/2"	1/2"	1/2"
P-4	SHOWER	FIBERGLASS, 36" x 36" RIBBED WOOD, 414, WHITE, SCREENED OVER, SINGLE LEVER CONTROL, PRESSURE BALANCED WITH SCREENER STOP, AMERICAN STANDARD RELIANT # 1485501, PROVIDE A CHROME STRAINER AND P-TRAP.	MOUNT @ 54" A.F.F.	2"	1-1/2"	1/2"	1/2"
P-5	HOSE BIBB	WATTS SR-1 W/SS-1 VACUUM BREAKER		-	-	-	1/2"
P-6	FLOOR DRAIN	SLOTTED ROUND COVER, PAIN SHALL DISCHARGE THROUGH A P-TRAP, OUTLET OF P-TRAP SHALL HAVE A TWO INCH DRAIN WITH INTERNAL FLOOR CLEANOUT.	PROVIDE BOTTLE W/ FROTHING SOAP AT LAV.	2"	-	-	-
P-7	WATER HEATER	30 GAL. ENERGY SAVING WITH 2" FOAM INSULATION, 20 GPM RECOVERY AT 80 TEMP. RISE, BROADFORD-WHITE MODEL W1-S88 OR APPROVED EQUAL, PROVIDED BY WELL CONTRACTOR	PROVIDE P&T RELIEF VALVE.	-	-	3/4"	3/4"
P-8	PRESSURE TANK	SUPERIOR SS-40, 40 GALLON TANK, 175 GALLON RECOVERY @ 140°F.	PROVIDE P&T RELIEF VALVE & VACUUM BREAKER.	-	-	3/4"	3/4"
P-9	STORAGE TANK	ELKAY DR-2222-10 STAINLESS STEEL SINK, AMERICAN STANDARD RELIANT # 4285401 FACET WITH SPIN, DAD STRAINER.	MOUNT WITH RIM @ 34" A.F.F.	1-1/2"	1-1/2"	1/2"	1/2"
P-10	SINK	ELKAY DR-2222-10 STAINLESS STEEL SINK, AMERICAN STANDARD RELIANT # 4285401 FACET WITH SPIN, DAD STRAINER.		1-1/2"	1-1/2"	1/2"	1/2"
P-11	LAVATORY	FAT L-1, WALL HUNG, W/STRONGER & PLUGS, FAUCET: AMERICAN STANDARD RELIANT # 2385000.		1-1/2"	1-1/2"	1/2"	1/2"
P-12	TOB	CARBON EQUIPMENT #01814 STAINLESS STEEL BOWL WITH WALL MOUNTING BRACKET.		1-1/2"	1-1/2"	1/2"	1/2"
P-13	LIMITED AREA SPRINKLER	INTERMEDIATE TEMPERATURE CLASSIFICATION (175-225) COLOR BRONZE WITH FRANGIBLE ELEMENT		-	-	3/4"	-
⊗	CLEANOUTS	AS INDICATED OR REQUIRED BY CODE, CLEANOUTS SAME SIZE AS PIPE, FLOOR CLEANOUTS TO BE SET FLUSH W/FLOOR, DOWN MODEL 1 OR APPROX. EQUAL, DOWN MODEL WILL CO. 3 SHALL BE DOWN MODEL 2-1/2 OR APPROX. EQUAL.		-	-	-	-

FLOOR PLAN

SCALE: 1/4" = 1'-0"

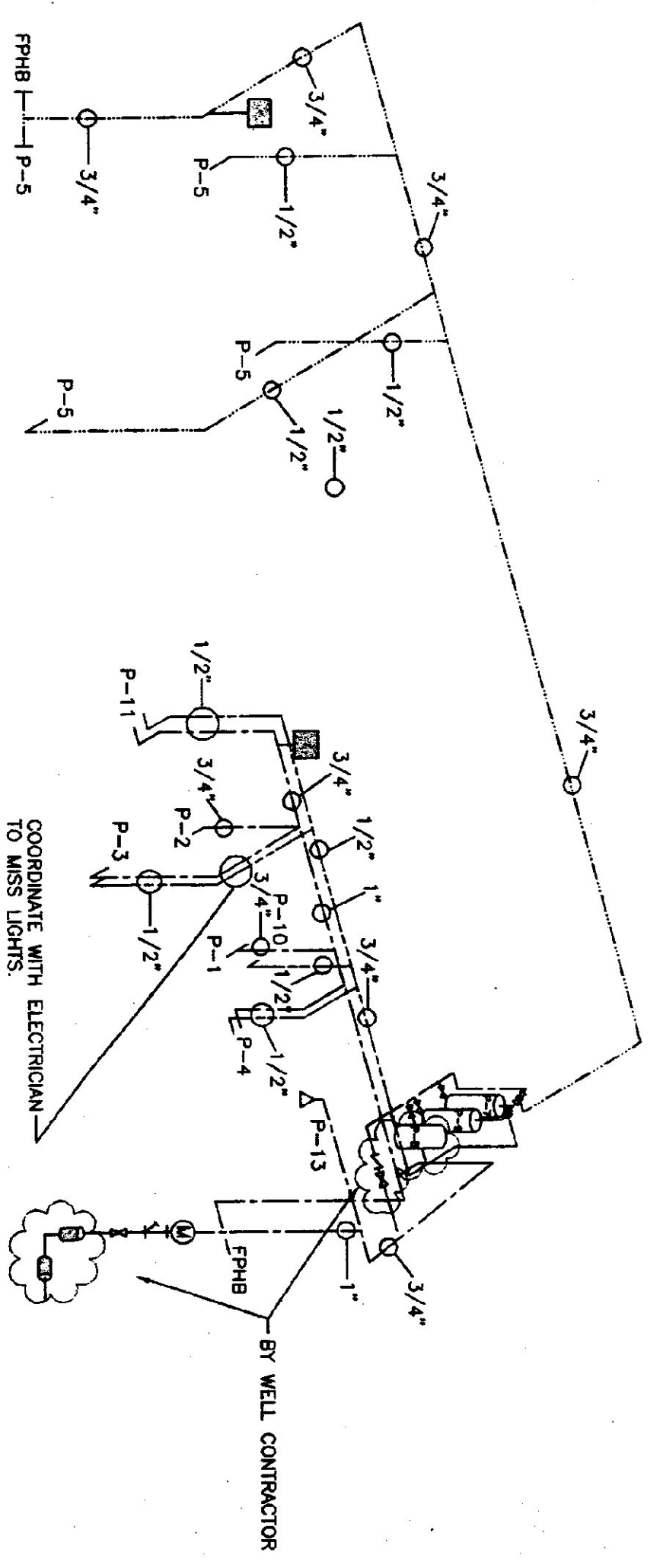
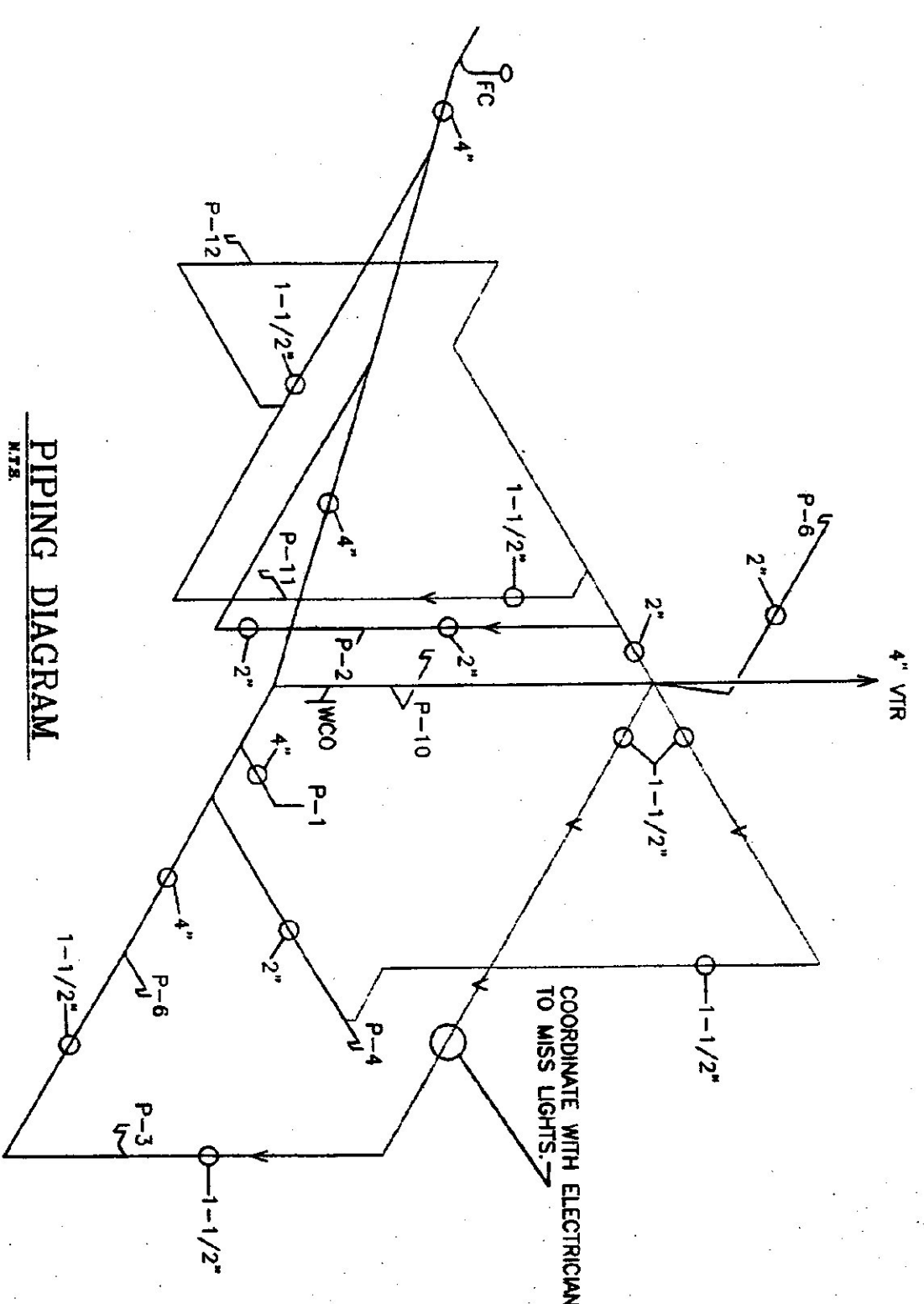
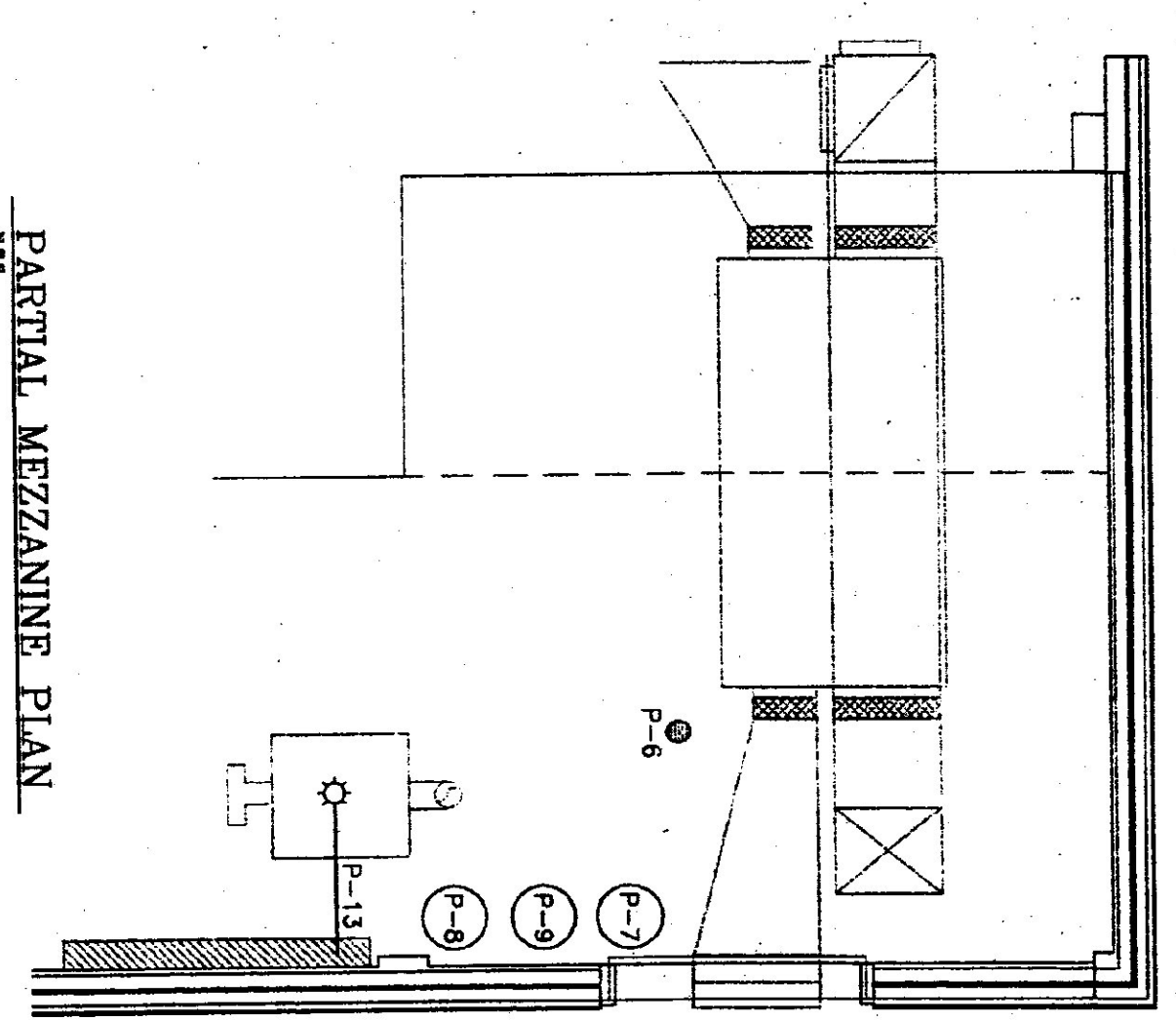
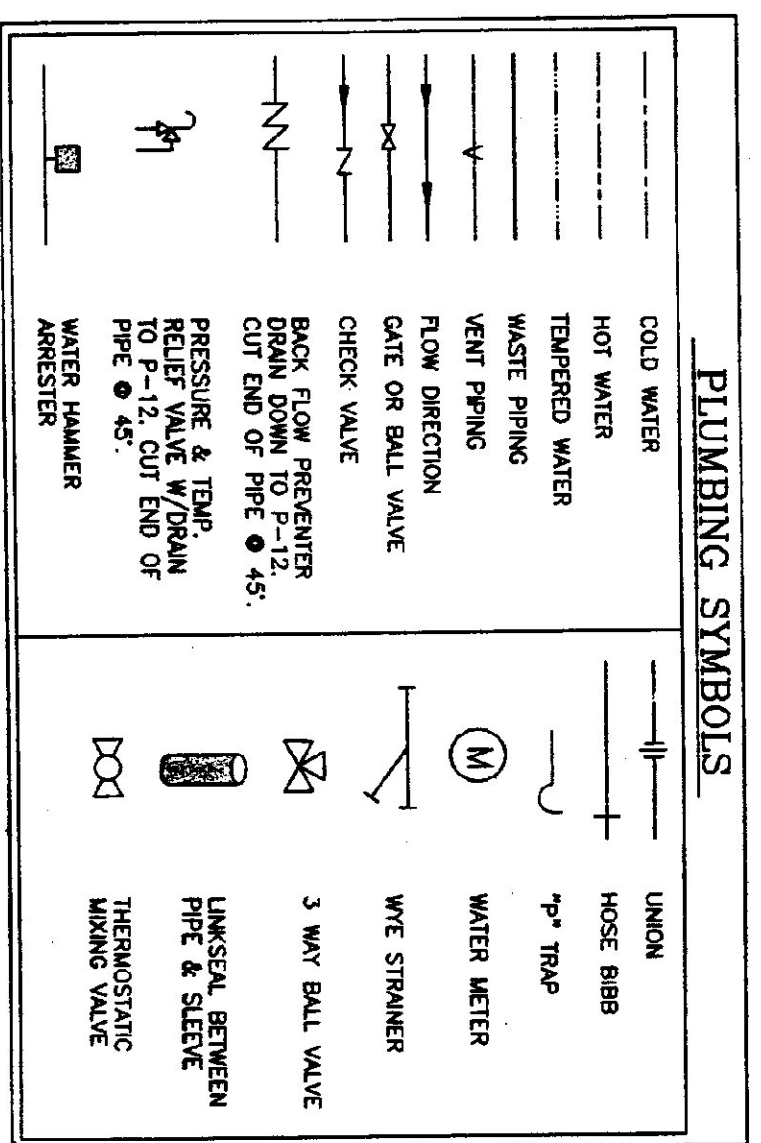

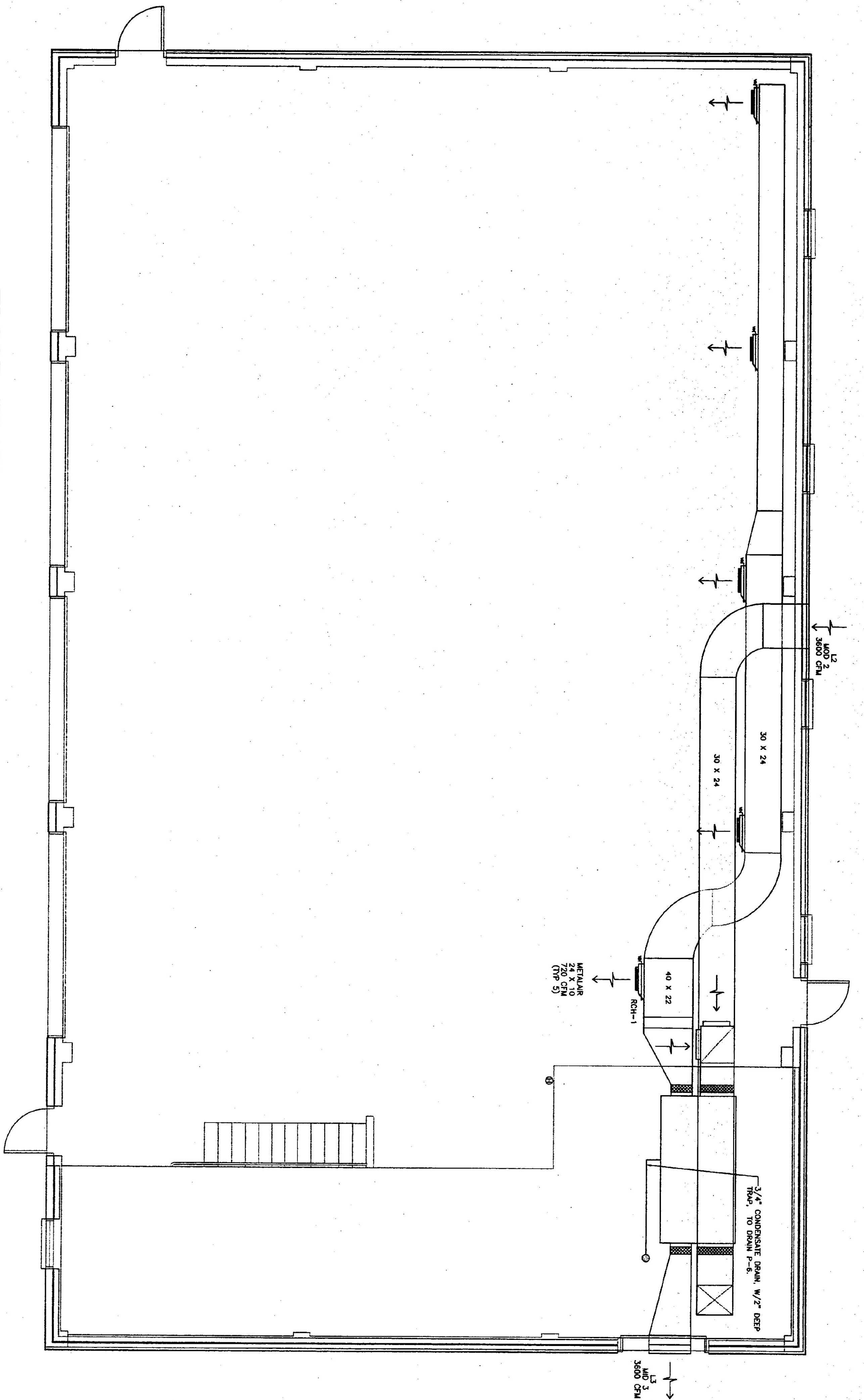

FLOOR PLAN

SCALE: 1/4" = 1'-0"

MAKE/MODEL	CAPACITIES			
RHC-1	MCQUAY SWB1410G-21X39	EAT 40	EWT 180	LMT 68
				LWT 160
				3600 CFM
				12 CFM

MAKE/MODEL	CAPACITIES			
HX-1	XETEX IQ-4000	3600 CFM @ 2" ESP	2 @ 3HP EA.	230/1/60

MAKE/MODEL	CAPACITIES		REMARKS
L-2,3	VENTPRODUCTS 2750	36X36	3600 CFM
MOD-2,3	VENTPRODUCTS 5703	36X36	3600 CFM
			PROVIDE BELIMO ACTUATORS

MAKE/MODEL	CAPACITIES	
P-8	TACO 0010	12gpm @ 8 IDH
		115V 1/9HP

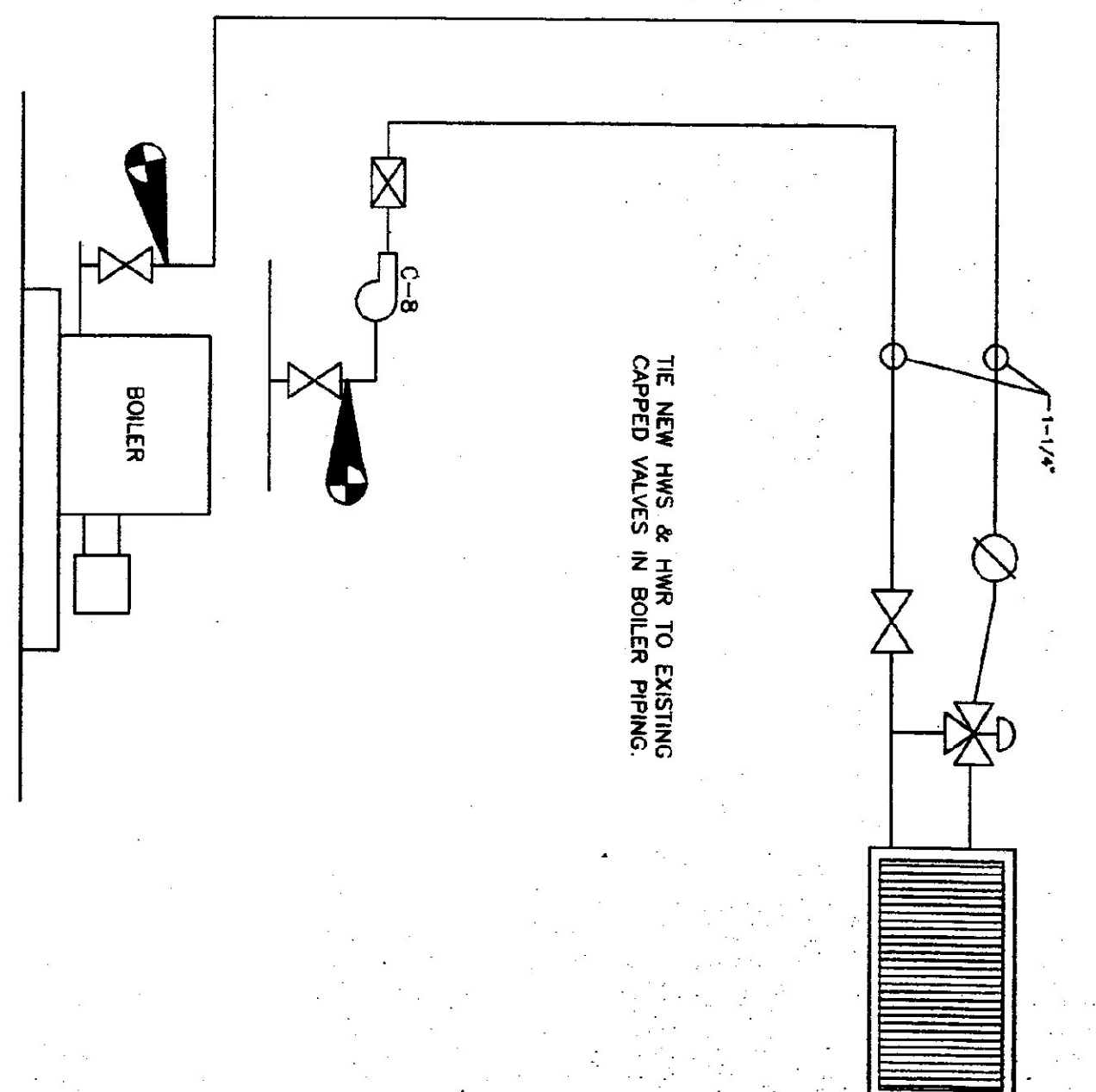
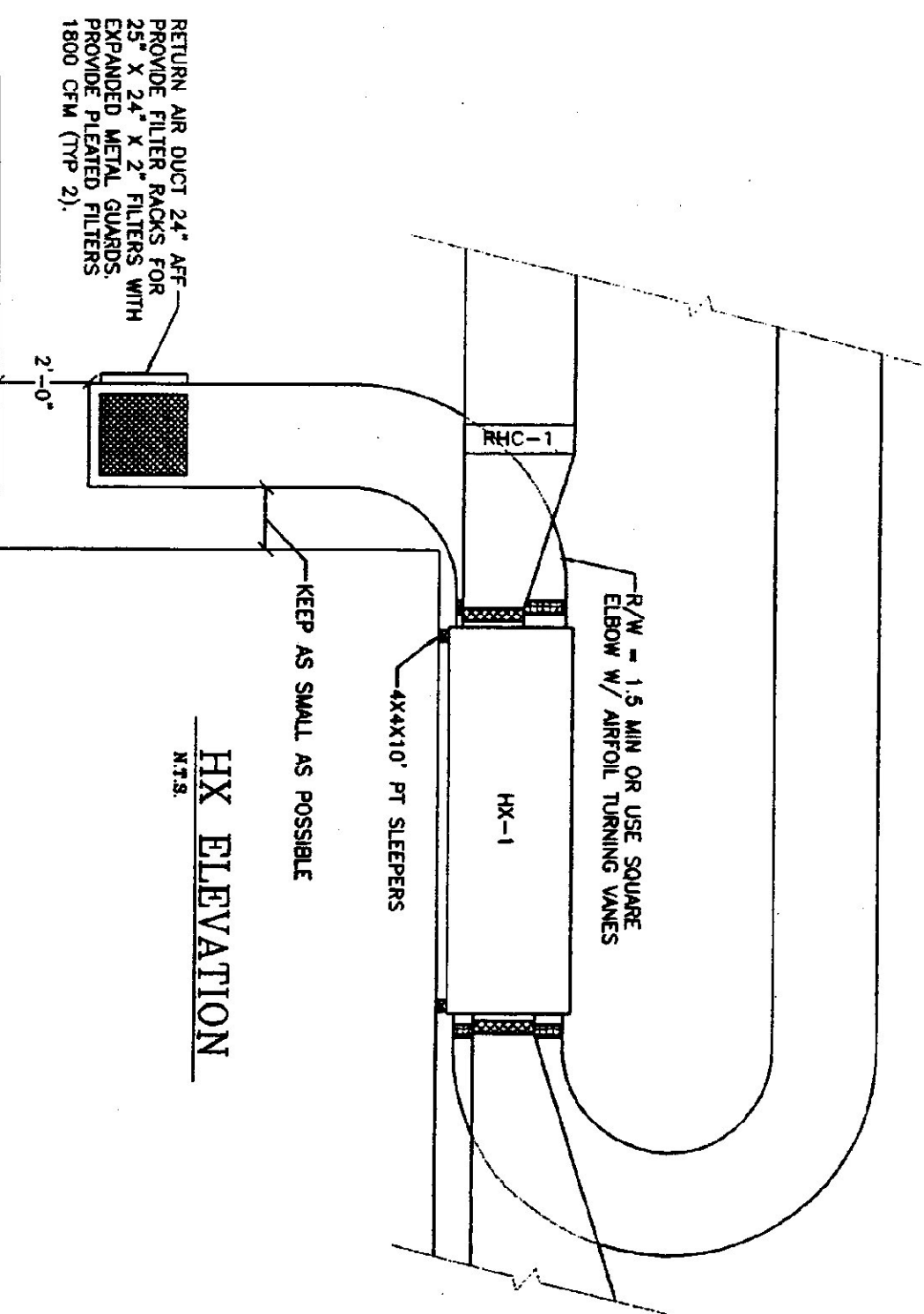

PIPING DIAGRAM

N.T.S.

SEQUENCES OF CONTROL
 When humidity rises above set point 50% (Adj.) MOD2&3 open. Both blowers in HX-1 are energized. C-8 is energized and 3 way valve modules to provide 65°F (Adj.) discharge air temp.
 When OAT rises above set point on exist. controller, C-8 as well as all de-energized.

LEGEND	
	BALL VALVE
	3-WAY THERMOSTATICALLY CONTROLLED VALVE
	BALANCING VALVE
	TOUR-ANDERSON STD
	HUMIDISTAT
	CIRCULATOR
	FLO-CHECK

READSBORO AOT GARAGE VENTILATION SYSTEM PLANS & DETAILS

READSBORO,

VERMONT



STATE OF VERMONT
 Department of Buildings
 and General Services
 Agency of Administration
 Montpelier, Vermont



REVISIONS

SCALE: AS NOTED
DATE: JUNE 2001
DRAWN BY: N. HERSEY
APPR. BY: SOUTHWORTH

READSBORO

VENTILATION
SYSTEM

PLANS & DETAILS

V-1

OF