

CENTERLINE 1' WIDE

CENTERLINE STRIPE 1' WIDE

APPROX. SCALE 1"=200'  
(OF RUNWAY)  
CLOSEUPS NOT TO SCALE

**NEWPORT STATE AIRPORT**  
PAIN T STRIPING DIAGRAM  
18/36 NONPRECISION RUNWAY  
05/23 VISUAL RUNWAY

REVISION 5/92 SDS

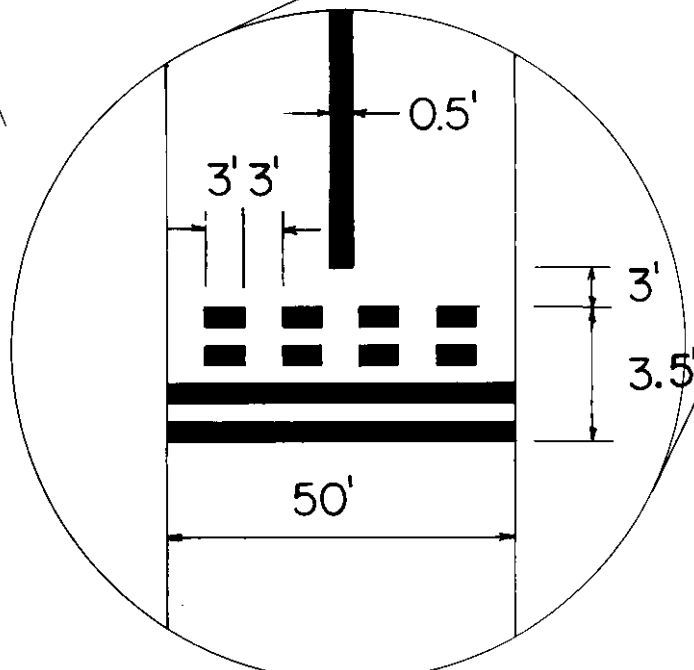

4 STRIPES and  
3 SPACES at 0.5' ea.

NOTE: SIDE STRIPES ARE NO LONGER  
NECESSARY PER AC 150/5340-1F  
CHANGE NO.1 DATED 8/16/91

- NOTES:
- 1) THE NUMBERS SHOULD BE NO CLOSER THAN TWO FEET FROM THE EDGE LINE OF THE RUNWAY.
  - 2) "ADJUSTMENTS TO THE LENGTHS OF THE STRIPES AND GAPS (OF THE CENTERLINE) WHERE NECESSARY TO ACCOMMODATE THE RUNWAY LENGTH, ARE MADE NEAR THE RUNWAY MIDPOINT." AC 150/5340-1F
  - 3) NUMERALS ARE SAME DIMENSIONS AT ALL ENDS.
  - 4) ALL RUNWAY MARKINGS ARE TO BE STRIATED WITH ALL STRIPES AND SPACES EQUAL IN WIDTH (4" to 6").
  - 5) CALCULATIONS OF PAINT QUANTITIES BASED ON SOLID MARKINGS (NOT STRIATED).