

APPROX. RUNWAY SCALE $\frac{1}{200}$
 1" = 200'
 CLOSEUPS NOT TO SCALE

- NOTES:
1. THE NUMBERS SHOULD BE NO CLOSER THAN TWO FEET FROM THE EDGE LINE OF THE RUNWAY.
 2. "ADJUSTMENTS TO THE LENGTHS OF THE STRIPES AND GAPS, (OF THE CENTERLINE) WHERE NECESSARY TO ACCOMMODATE THE RUNWAY LENGTH, ARE MADE NEAR THE RUNWAY MIDPOINT." AC-150/5340-1F
 3. CALCULATIONS BASED ON SOLID MARKINGS (NOT STRIATED)
 4. ALL RUNWAY MARKINGS ARE TO BE STRIATED WITH ALL STRIPES EQUAL IN WIDTH (4" to 6").
 5. CENTERLINE AND SPACING TYPICAL.

PAINT QUANTITIES				
LOCATION	SQUARE FEET	No. OF GALLON	COLOR	
	1/19	1/19	WHITE	YELLOW
CENTERLINE STRIPE	1710	17	★	
NUMERALS	1496	15	★	
HOLDING POSITION MARKING	90	1		★
TAXIWAY CENTERLINE	550	6		★

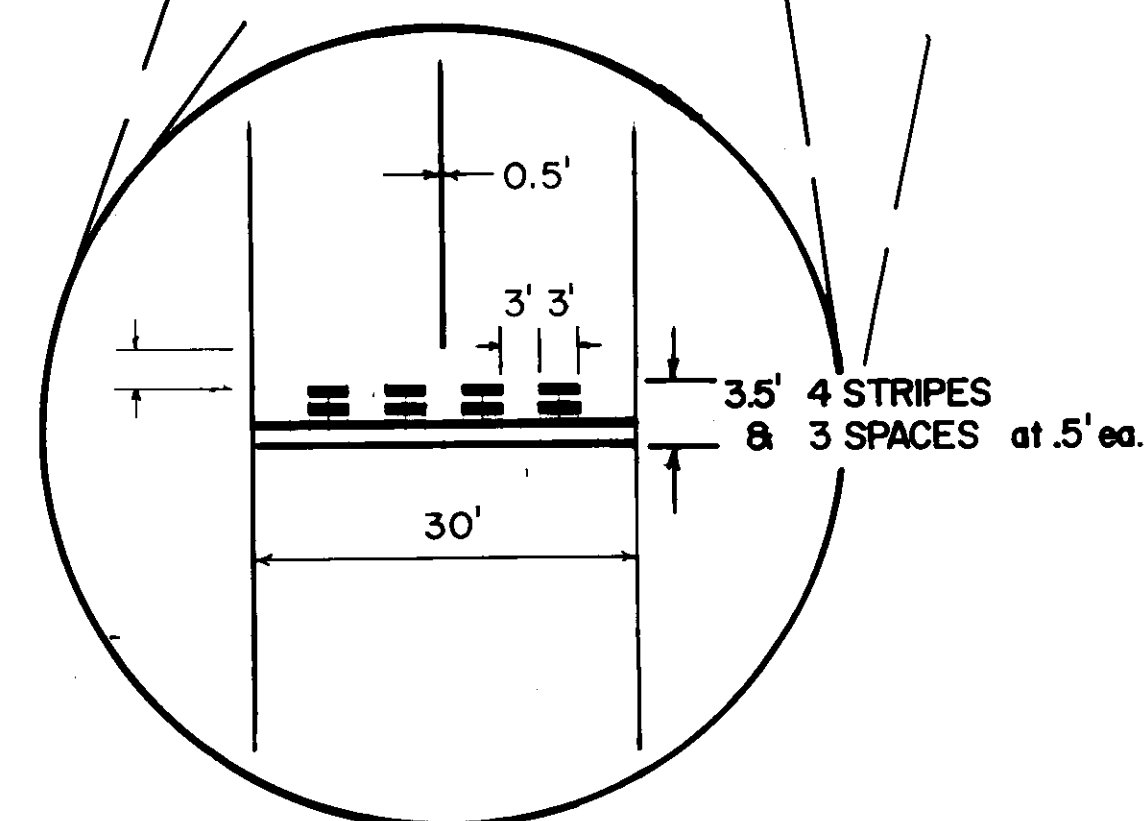

FRANKLIN COUNTY STATE AIRPORT
 PAINT STRIPING DETAIL
 1/19 VISUAL RUNWAY

REVISION 6/89 SLB
 5/92 SDS

NOTE: SIDE STRIPES ARE NO LONGER NECESSARY PER AC 150/5340-1F CHANGE NO.1 DATED 8/16/91