

NOTE: SIDE STRIPES ARE NO LONGER NECESSARY PER AC 150/5340-1F CHANGE NO. 1 DATED 8/16/91

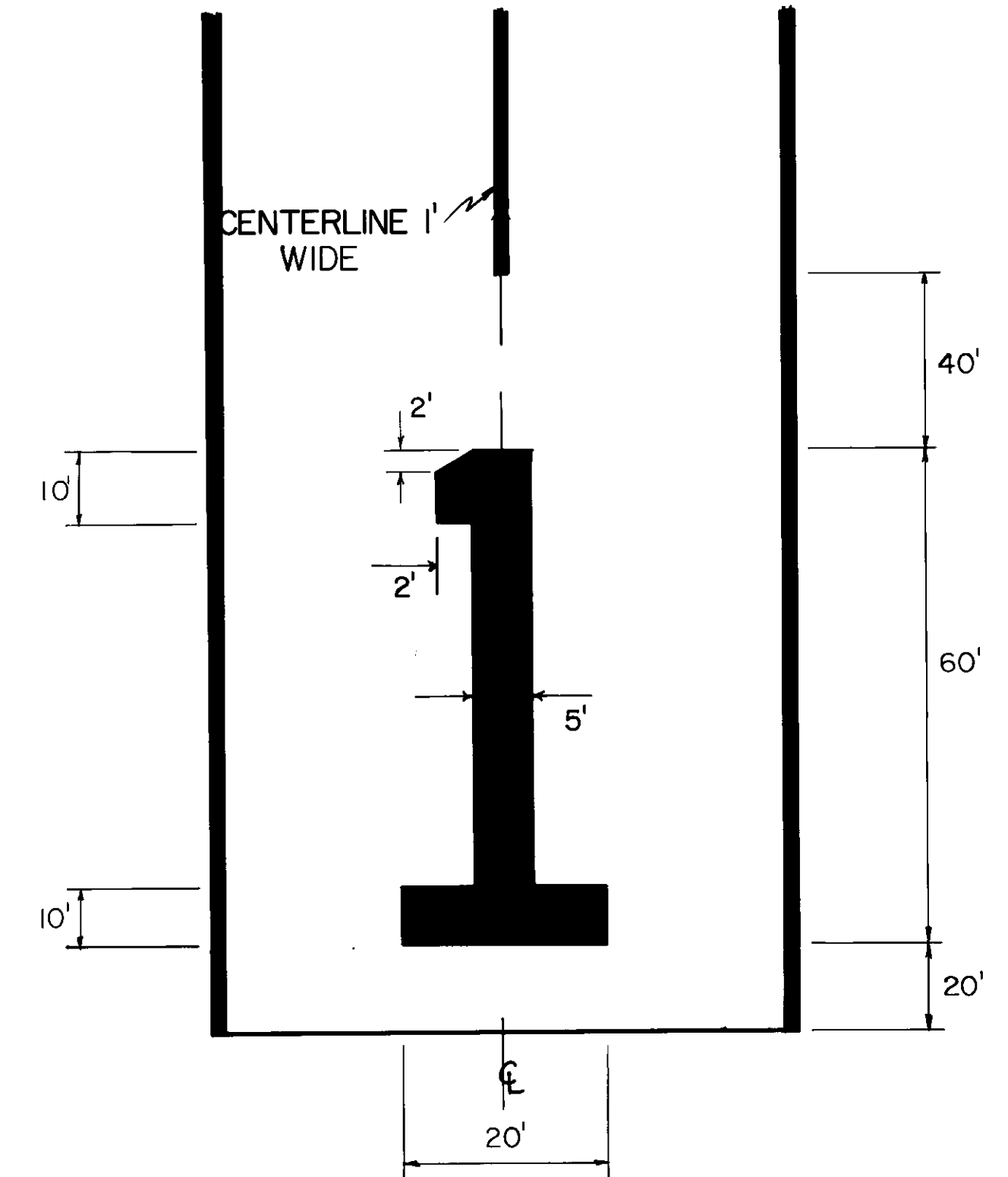
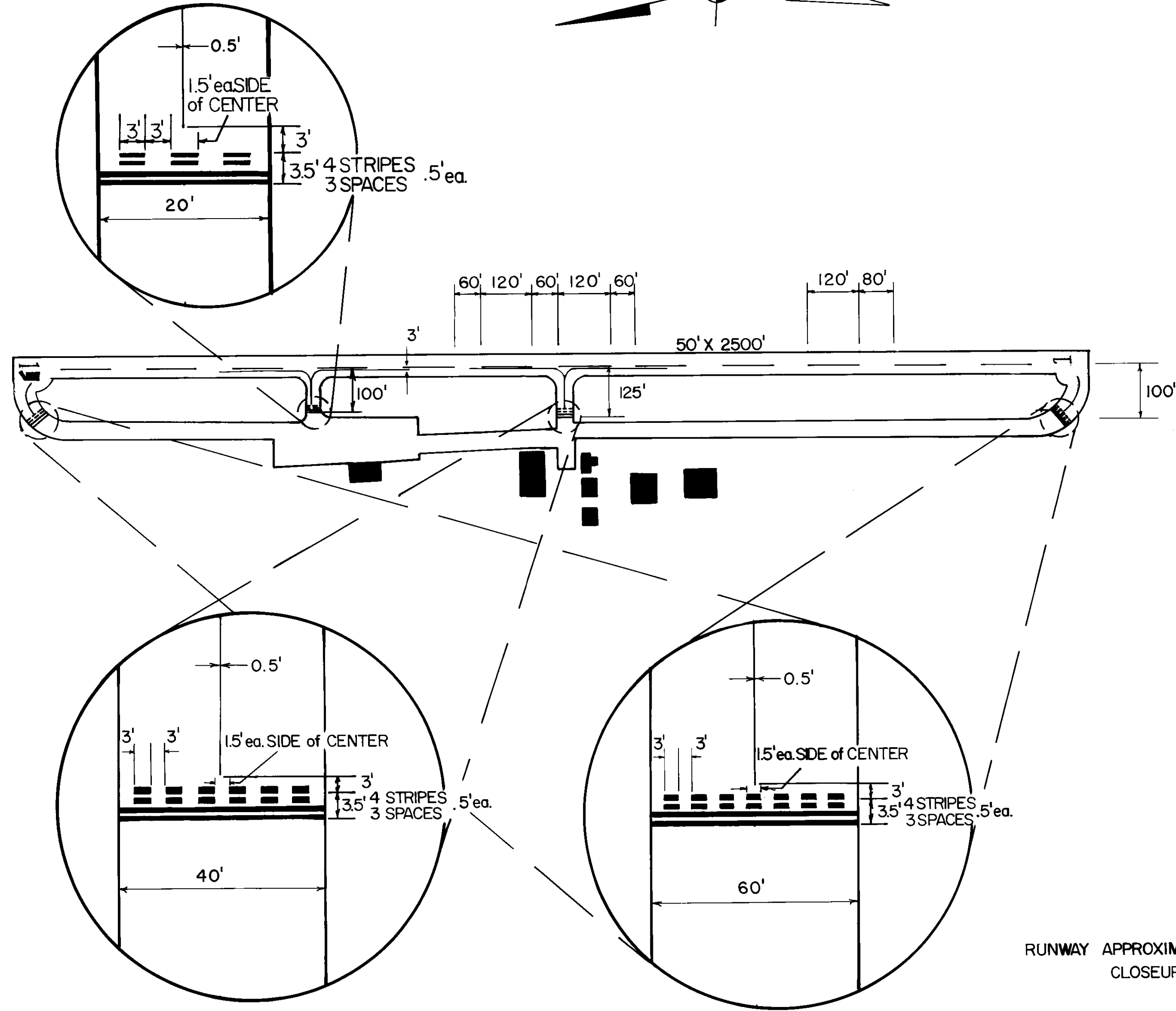
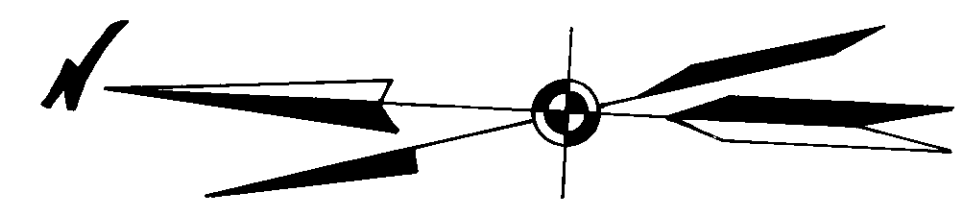
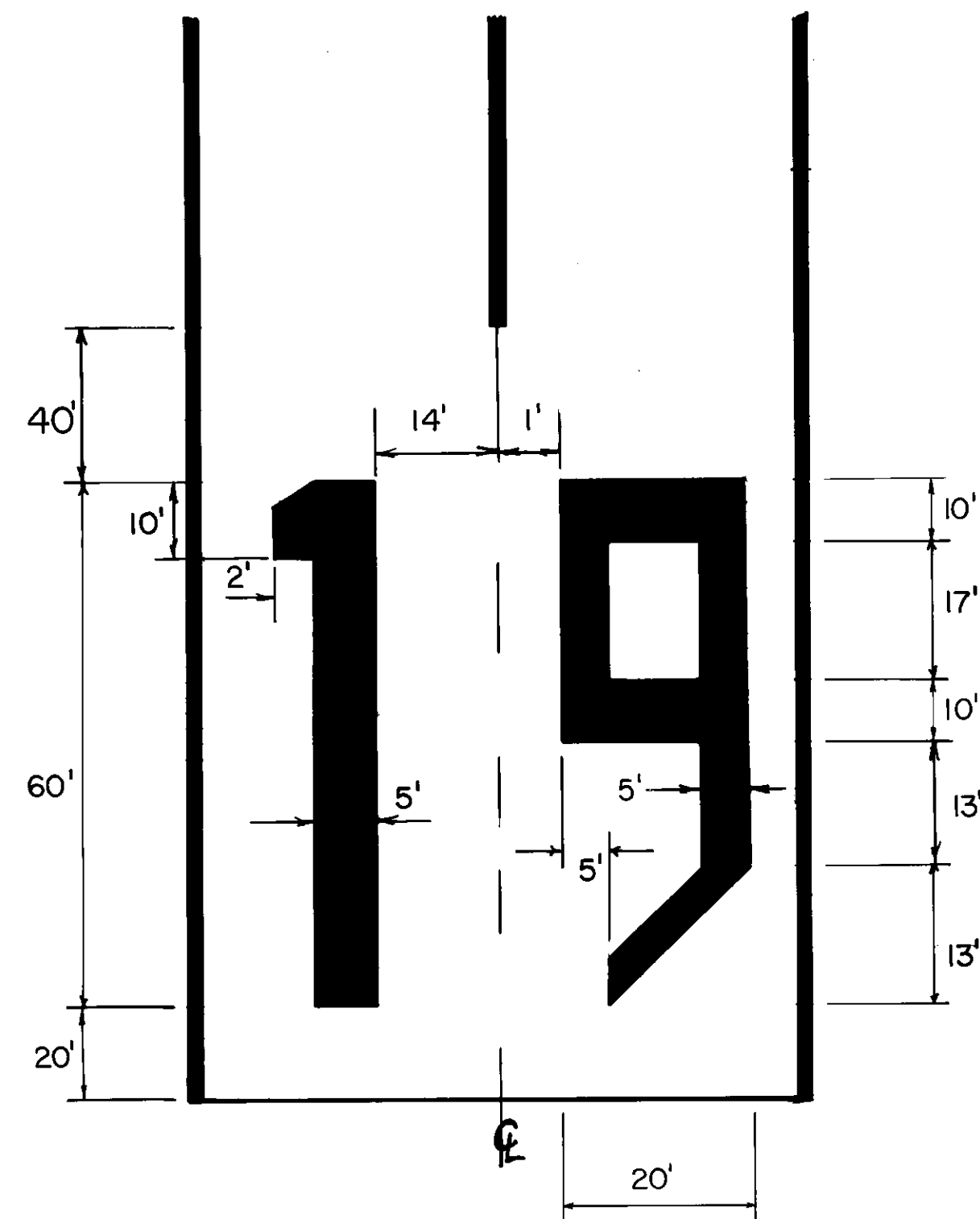

- NOTES:
1. THE NUMBERS SHOULD BE NO CLOSER THAN TWO FEET FROM THE EDGE LINE OF THE RUNWAY.
  2. "ADJUSTMENTS TO THE LENGTHS OF THE STRIPES AND GAPS, (OF THE CENTERLINE) WHERE NECESSARY TO ACCOMMODATE THE RUNWAY LENGTH, ARE MADE NEAR THE RUNWAY MIDPOINT." AC-150/5340-1F.
  3. CALCULATIONS BASED ON SOLID MARKINGS (NOT STRIATED).
  4. ALL RUNWAY MARKINGS ARE TO BE STRIATED WITH ALL STRIPES AND SPACES EQUAL IN WIDTH (4" TO 6").
  5. CENTERLINE AND SPACING TYPICAL.
  6. STANDARD HOLDING POSITION DIMENSIONS ARE THE SAME AT BOTH ENDS.
  7. NUMERALS ARE SAME DIMENSIONS AT BOTH ENDS.

PAINT QUANTITIES				
LOCATION	SQUARE FEET	No. OF GALLONS	COLOR	
			WHITE	YELLOW
CENTERLINE STRIPE	1440	15	★	
NUMERALS	1496	15	★	
HOLDING POSITION MARKING	264	3		★
TAXIWAY CENTERLINE	926	9		★

RUNWAY APPROXIMATE SCALE  $\frac{0 \quad 20 \quad 100 \quad 200}{1" = 200'}$   
CLOSEUPS NOT TO SCALE

MIDDLEBURY STATE AIRPORT  
PAINT STRIPING DETAIL  
1/19 VISUAL RUNWAY

REVISION 6/89 SLB  
5/92 SDS