

CONTRACTION JOINT DETAIL
NO SCALE

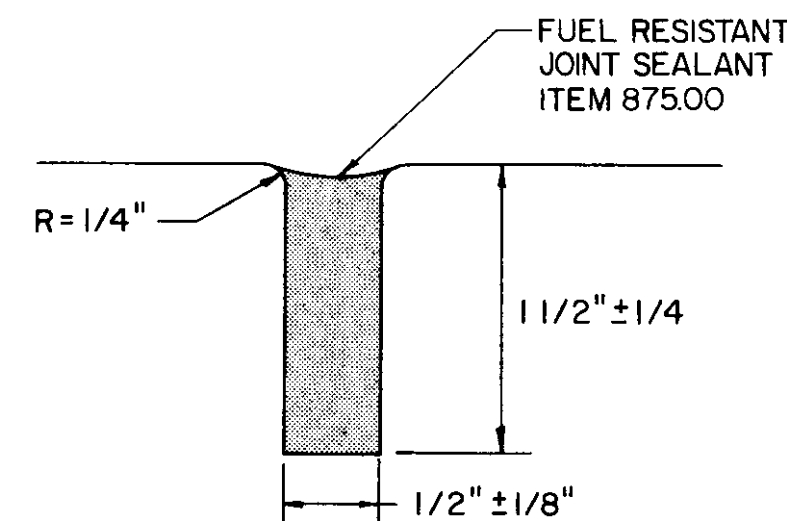

JOINT FILLER DETAIL
NO SCALE

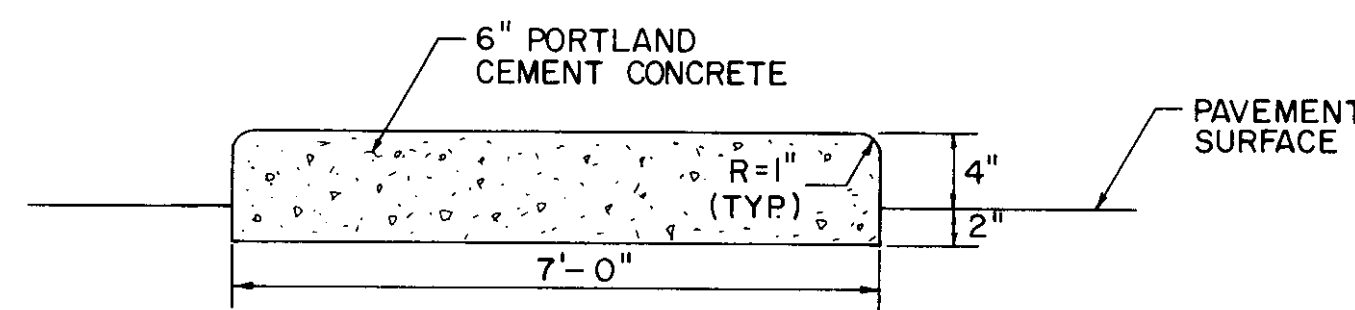

FUEL CABINET PAD DETAIL
NO SCALE

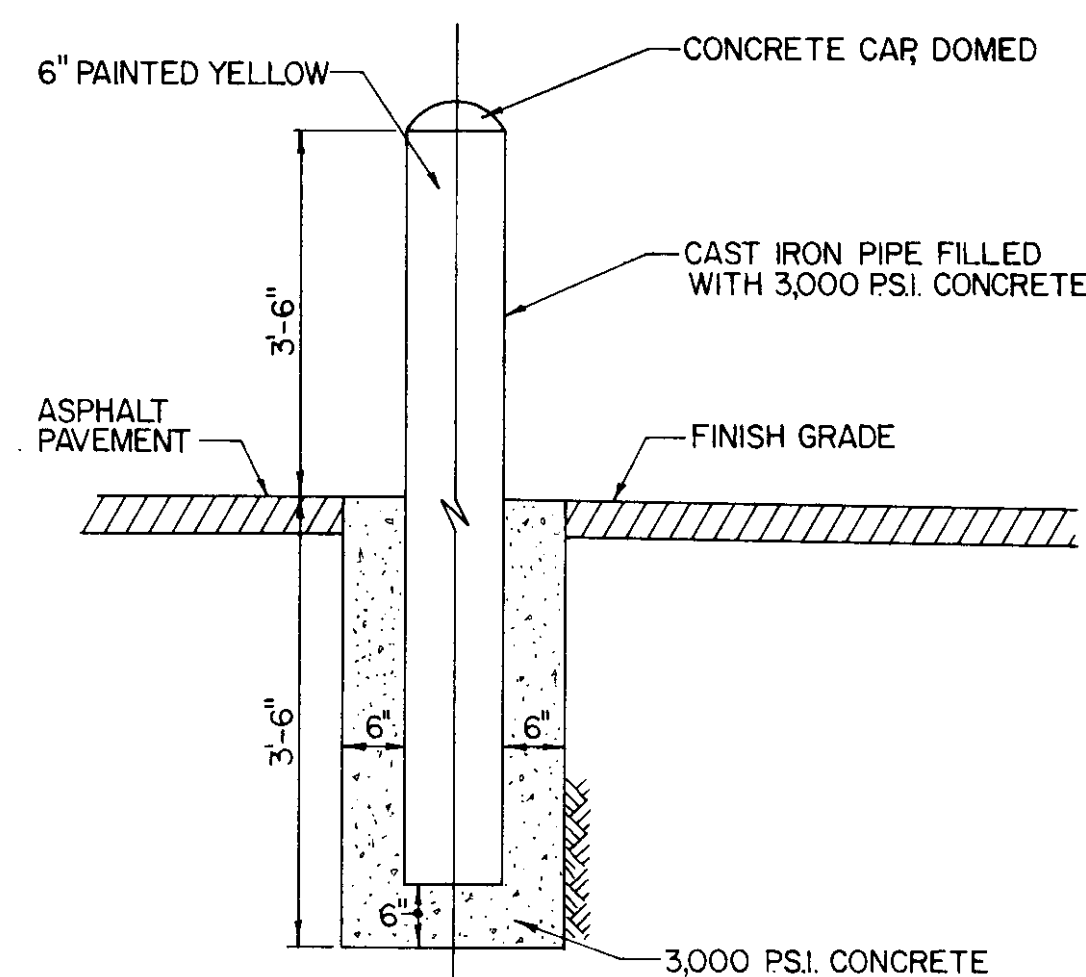

BOLLARD DETAIL
NO SCALE

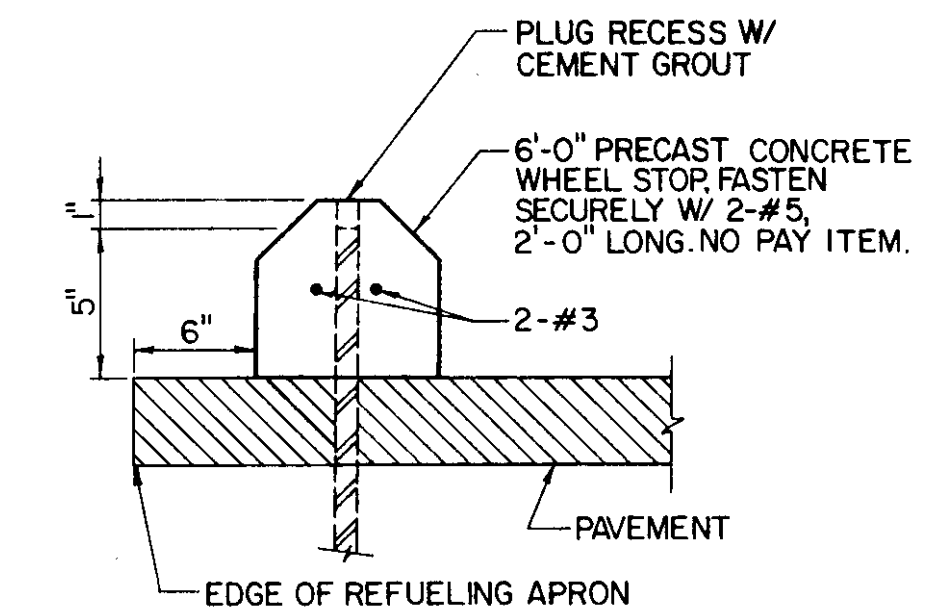

CONCRETE WHEEL STOP DETAIL
NO SCALE

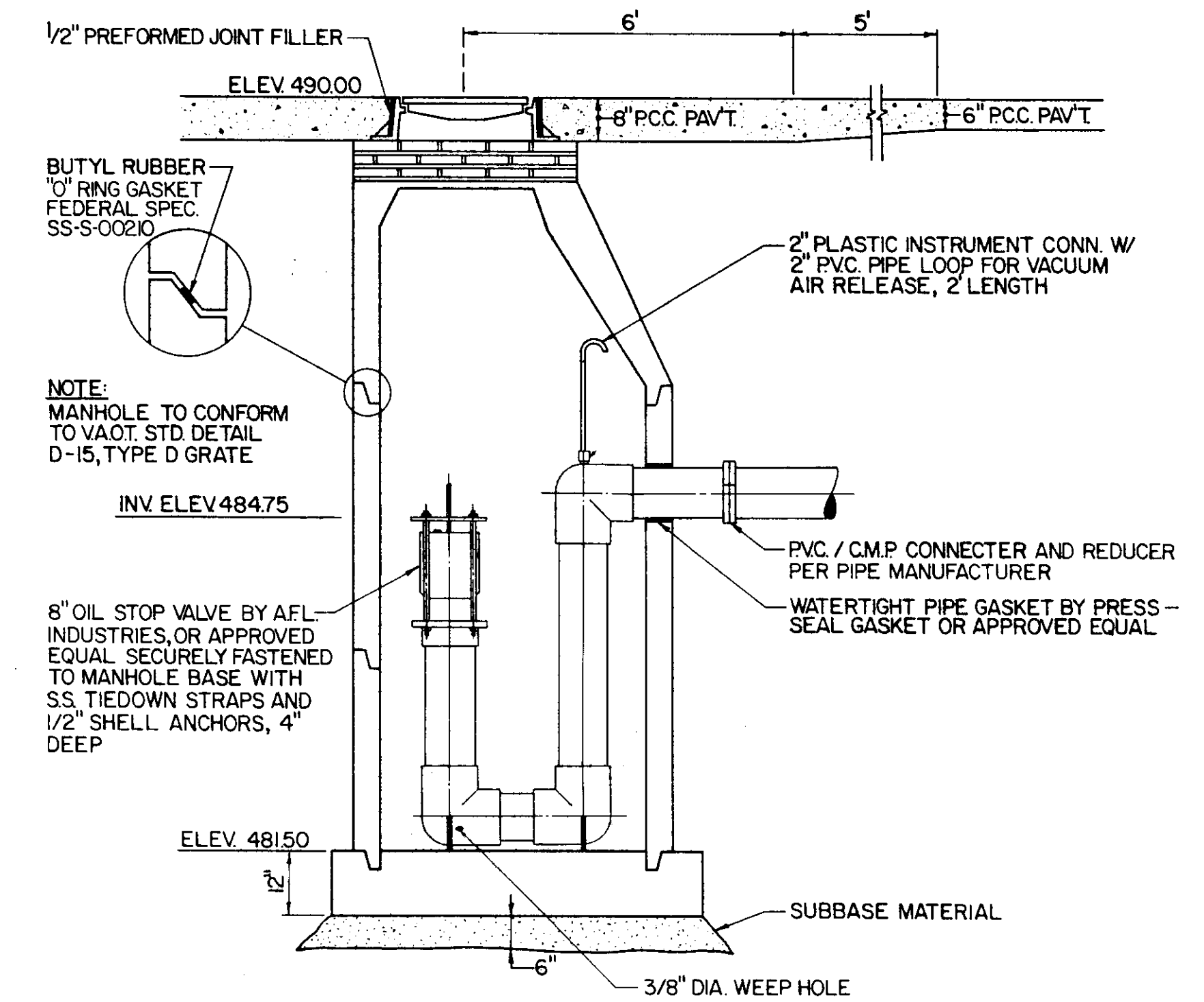

OIL / WATER SEPARATOR
NO SCALE

REVISION		DATE	DETAILS			
BY		DATE	MIDDLEBURY STATE AIRPORT FUELING SYSTEM A.I.R. 03-2069 TOWN OF MIDDLEBURY			
DRAWN		CHECKED				
PM		MC.				
PROJECT		DATE	SCALE	DWG.	SHEET	OF
1981-03		JULY 1990	AS SHOWN	D-1	6	10