

- LOD NOTES:
1. THE POWER FOR AN LOD MUST BE WIRED TO THE SAME SOURCE AS THE LIGHTS THEY ARE MONITORING.
 2. ONE REFERENCE VOLTAGE PER LOD PER HCA ANALOG INPUT.
 3. A RESISTOR MUST ALWAYS BE INSTALLED IN SERIES BETWEEN THE LOD OUTPUTS AND THE HCA ANALOG INPUTS.
 4. THE NUMBER OF UNIQUE REFERENCE VOLTAGES IS DETERMINED BY THE NUMBER OF UNIQUE BATTERY BANKS AND/OR LIGHTING TRANSFORMERS.
- HCA NOTES:
1. CPU BOARD REV LEVEL 'F' OR HIGHER.
 2. SOFTWARE REV LEVEL 'UP1-NC' OR GREATER ON IC13.
 3. DIP SWITCH #1: ON, ON, ON, OFF, ON, ON, OFF, OFF.
 4. DIP SWITCH #2: OFF, OFF, OFF, OFF, OFF, OFF, OFF, OFF.
 5. JUMPER ALL UNUSED DIGITAL '+' INPUTS TO POSITIVE BATTERY.
 6. JUMPER ALL UNUSED DIGITAL '-' INPUTS TO NEGATIVE BATTERY.
 7. DO NOT JUMPER INPUTS WITH DIFFERENT VOLTAGE REFERENCES TOGETHER.

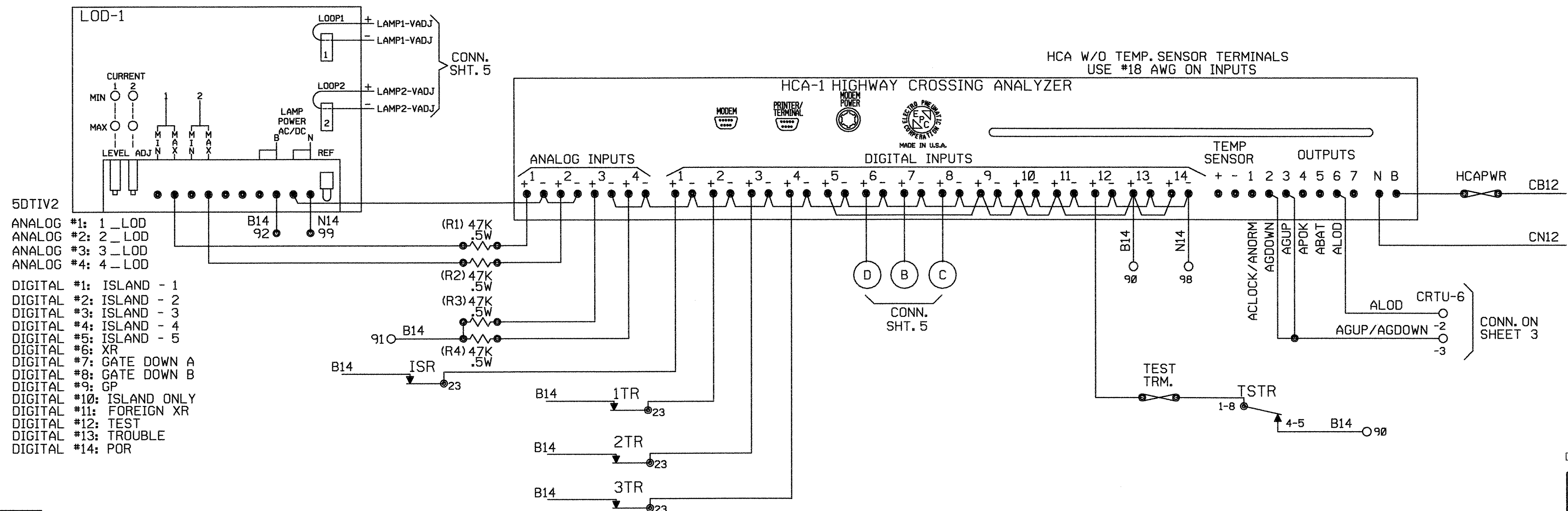

SIGNAL POWER DISTRIBUTION DIAGRAM
 DOT# 247-536R

PROJECT NAME: SHARON GRADE CROSSING
 PROJECT NUMBER: STP2034 (13)S

FILE NAME: SHT27.DGN
 PROJECT LEADER: H. PATEL
 DESIGNED BY: R. CARROLL

PLOT DATE: 06/13/03
 DRAWN BY: A. BOSE
 CHECKED BY: G. SERGOT

SHEET 26 OF 35

DATUM
 VERTICAL NAVD88 ± 0.5 FT.
 HORIZONTAL SPC 1983

ORIGINAL PREPARED:		
DATE	REVISIONS	BY

NOT TO SCALE

09:12:05 AM
 06/13/03
 M:\187379_vt_rail_xina\SHARON_CROSSING.dgn\SHT26.dgn