

WATER / SEWER CROSSING NOTES

1. WATER MAINS AND SEWERS WHICH CROSS SHALL HAVE A MINIMUM VERTICAL CLEARANCE OF 18 INCHES.
2. WATER AND SEWER PIPE JOINTS SHALL BE LOCATED AS FAR APART AS POSSIBLE.
3. PROVIDE STRUCTURAL SUPPORT FOR EXPOSED WATER AND SEWER PIPES.
4. FOR PARALLEL INSTALLATION, THERE SHALL BE A HORIZONTAL SEPARATION OF 10 FEET BETWEEN WATER MAINS AND SANITARY SEWER, AND A SEPARATION OF 5 FT BETWEEN WATER MAINS AND STORM SEWERS.
5. IN THE EVENT 18 INCHES OF VERTICAL CLEARANCE OR 10' OF HORIZONTAL SEPARATION CANNOT BE ACHIEVED, THE SANITARY SEWER PIPE MUST BE CONSTRUCTED TO WATER MAIN STANDARDS FOR A MINIMUM OF THREE PIPE LENGTHS CENTERED ON THE WATER LINE.

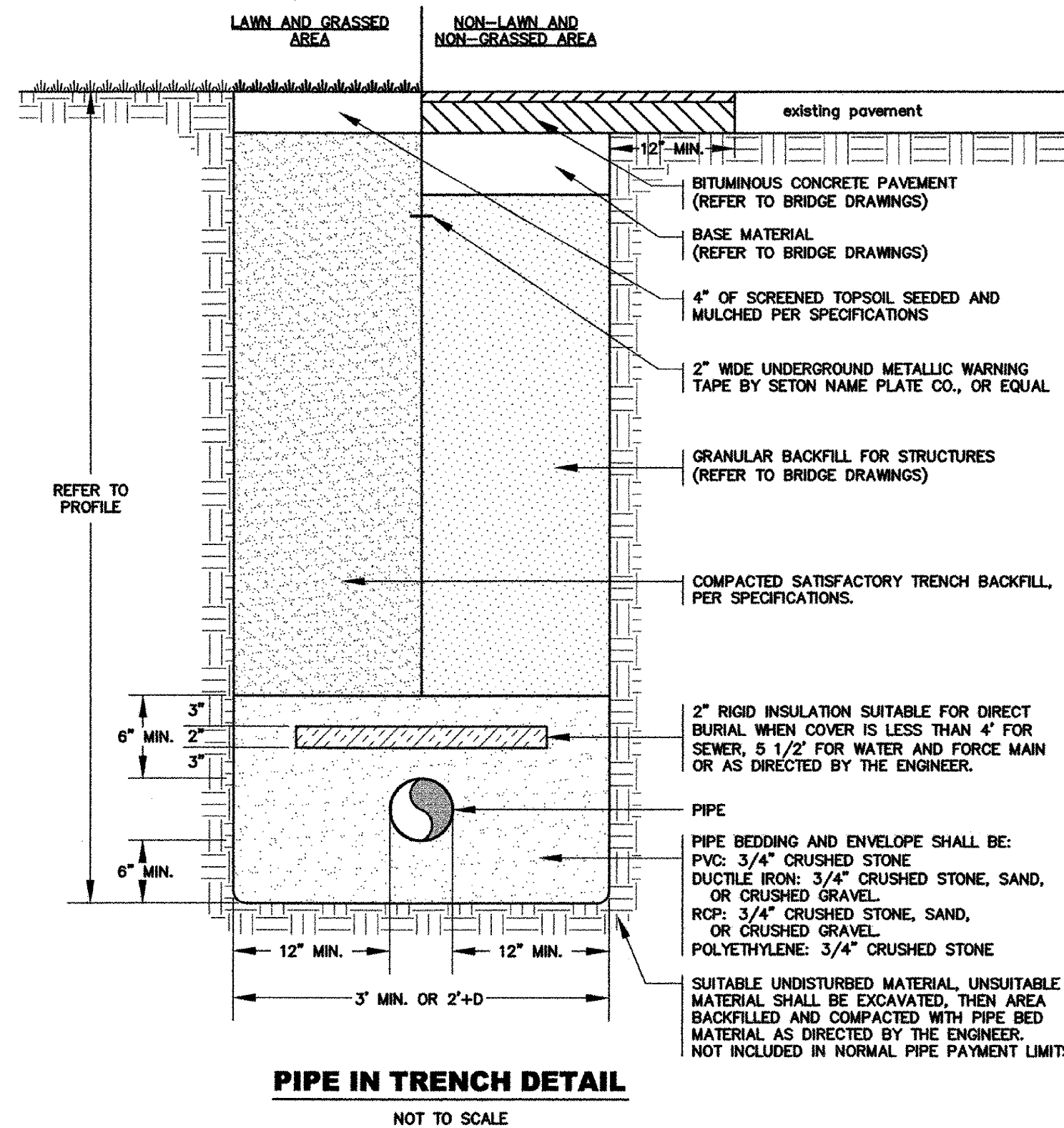

- NOTES:**
1. REFER TO WATER MAIN ON BRIDGE AND SEWER MAIN ON BRIDGE SPECIAL PROVISIONS FOR TESTING REQUIREMENTS FOR WATER MAIN AND SEWER MAIN RESPECTIVELY.
 2. REFER TO WATER MAIN ON BRIDGE SPECIAL PROVISIONS FOR WATER MAIN FLUSHING AND DISINFECTION REQUIREMENTS.

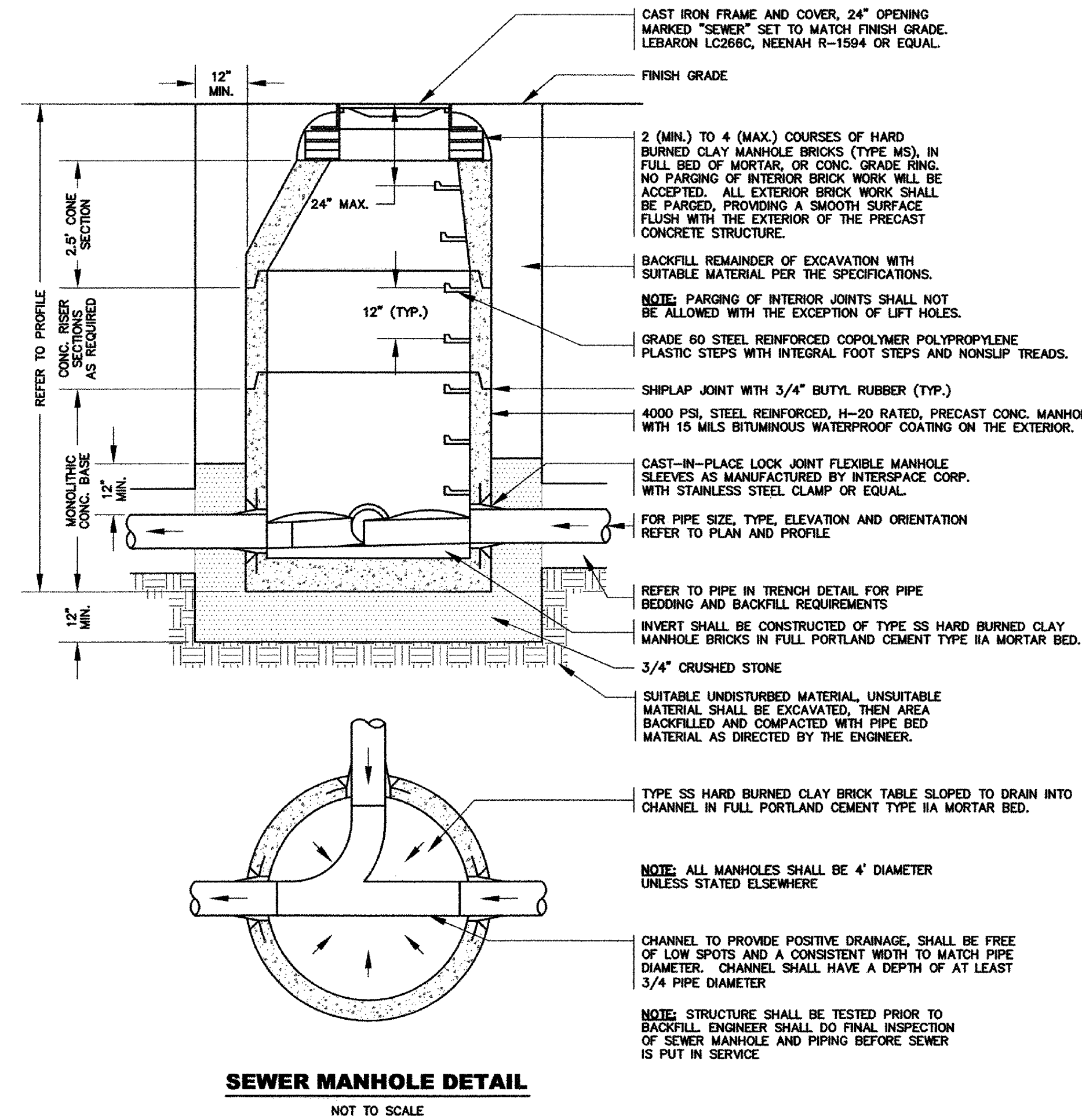

WASTEWATER MANHOLE VACUUM TESTING NOTES:

1. ENGINEER SHALL WITNESS ALL TESTING.
2. MANHOLES SHALL BE VACUUM TESTED BEFORE BACKFILLING.
3. ALL PIPE OUTLETS SHALL BE PLUGGED WITH TEST PLUGS. BRACE ALL PLUGS SECURELY.
4. PLACE THE TEST DEVICE OVER THE ACCESS OPENING AND INFLATE THE RUBBER RING TO SEAL BETWEEN THE TEST DEVICE AND THE MANHOLE CONE.
5. SLOWLY PUMP AIR OUT OF THE MANHOLE UNTIL A VACUUM IS CREATED INSIDE OF THE MANHOLE EQUAL TO TEN INCHES (10") OF MERCURY ON A CALIBRATED VACUUM GAUGE. THE REMOVAL OF AIR SHALL THEN BE STOPPED AND THE TEST BEGUN.
6. THE VACUUM MUST NOT DROP TO BELOW NINE INCHES (9") OF MERCURY WITHIN A TWO MINUTE TEST PERIOD.
7. IF MORE THAN ONE INCH (1") DROP IN VACUUM OCCURS WITHIN THE TWO MINUTE TEST PERIOD, THE MANHOLE HAS FAILED THE TEST AND SHALL BE REPAIRED OR RECONSTRUCTED AND RETESTED.
8. THE CONTRACTOR SHALL MAKE ALL REPAIRS OR REPLACEMENTS NECESSARY TO OBTAIN PASSING TEST RESULTS, AT NO ADDITIONAL EXPENSE TO THE OWNER.
9. DO NOT REMOVE PLUGS UNTIL INTERNAL VACUUM IS COMPLETELY RELEASED.

AREA OF BEARING FACE OF CONCRETE THRUST BLOCKS (IN SQUARE FEET)

PIPE SIZE (INCHES)	AREA OF BEARING FACE OF CONCRETE THRUST BLOCKS (IN SQUARE FEET)	
	SOFT WET CLAY, SAND OR SILT (1000 PSF)	DRY SAND (3000 PSF)
CAP OR TEE		
8 OR LESS	20 SF	7 SF
10	29	10
12	41	14
90° BEND		
8 OR LESS	27 SF	9 SF
10	41	14
12	58	19
45° BEND		
8 OR LESS	15 SF	5 SF
10	22	7
12	31	11
22 1/2° BEND OR LESS		
8 OR LESS	8	3
10	11	4
12	16	5
REDUCER		
8 OR LESS	8 SF	7 SF
10	11	7
12	16	11

NOTE: BEARING SURFACE AREAS CALCULATED ASSUMING A MAXIMUM WORKING PRESSURE OF 150 PSI AND A 2:1 SAFETY FACTOR FOR SURGE

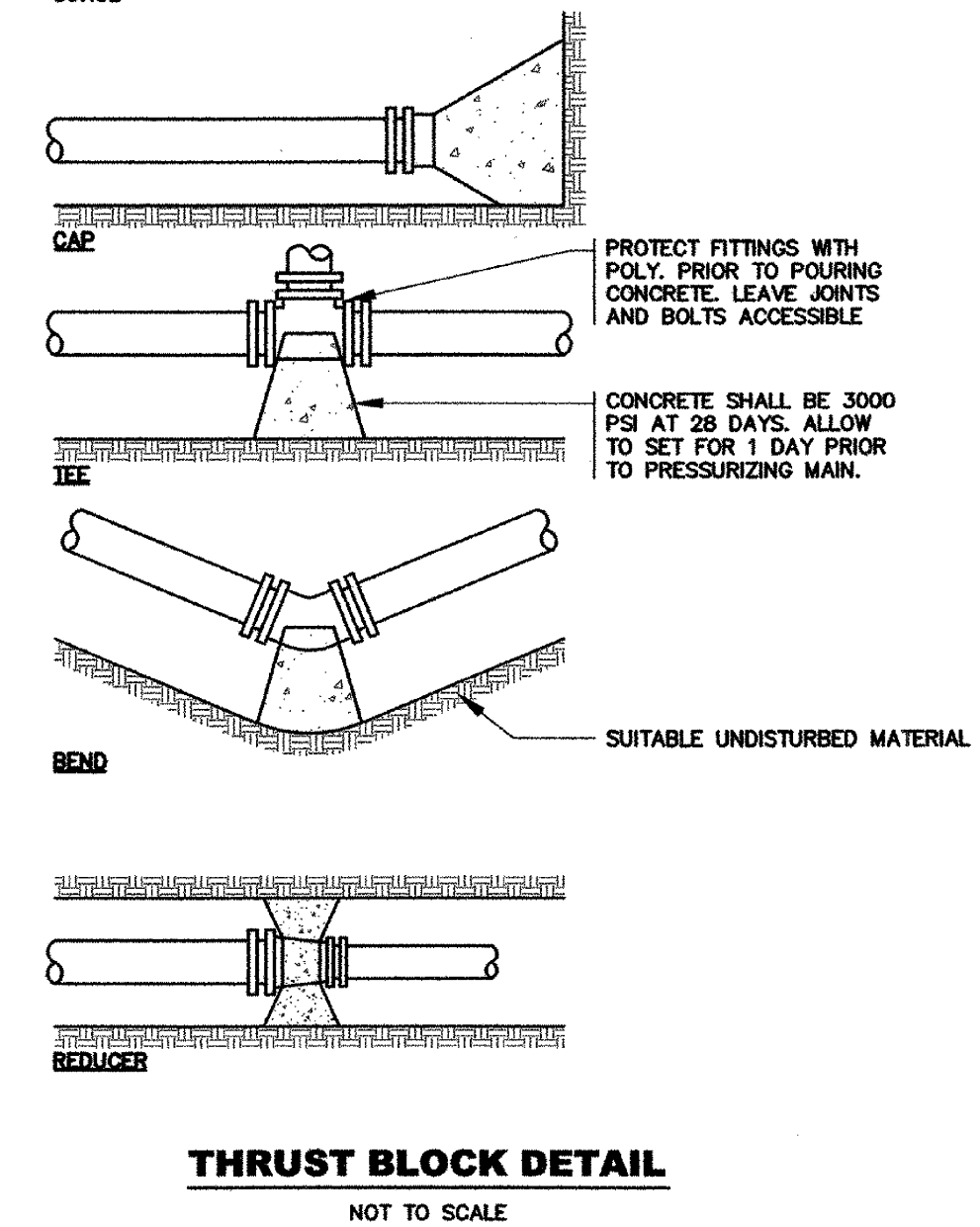

40+ East Main Street
P.O. Box 712
East Middlebury, VT 05740
Telephone: 802.382-6922
Fax: 802.382-6640
110 Merchants Row
4th Floor, Suite 15
Rutland, VT 05701
Telephone: 802.747-3080
Fax: 802.747-1620
E-mail: info@otterck.com



**STATE OF VERMONT
AGENCY OF TRANSPORTATION**

Town Of **JOHNSON** Bridge No. **5**
Highway No. **1** Log Sta. _____
Surv. Sta. _____

TH NO. 1 OVER THE GIHON RIVER

NOTES AND DETAILS

Designed By **P.D.** Drawn By **J.L./H.B.**
Checked By **Date** Bridge Design Supervisor
C.C. **1/09** **Date** **1/09**

PROJECT **JOHNSON** PROJECT NO. **BHO 1448 (29)**
OCE DWG NO. **C-4**

Bridge Sheet No. _____ Sheet **67** of **68**