

STATION I+130.000
 END PROJECT STP 1443(45)
 BEGIN PROJECT STP 1443(46)

MATCH LINE
 (SEE SHEET 62)

MATCH LINE
 (SEE SHEET 62)

BEGIN BRIDGE 19
 STA I+059.000
 F.G. = 495.734

END BRIDGE 19
 STA I+072.500
 F.G. = 496.314

PI
 Sta I+043.192 BK=
 Sta I+042.674 AHD

CHANNEL POE
 Sta 7+050.000

PC
 Sta I+074.842

END APPROACH
 STA I+020.000
 BEGIN PROJECT
 STP 1443(45)

STATION I+005.000
 BEGIN APPROACH

POB
 Sta I+000.000

PT
 Sta I+056.123
 POST Sta I+051.828 =
 Cha Sta 7+023.197
 Δ = 55° LT

STONE FILL
 TYPE I (TYP)

STONE FILL
 TYPE IV (TYP)

PI
 Sta I+087.080 BK=
 Sta I+086.356 AHD

PT
 Sta I+098.594

CHANNEL POB
 Sta 7+000.000

PC
 Sta I+029.742

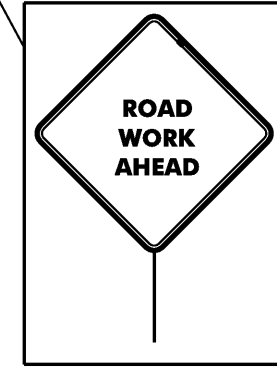
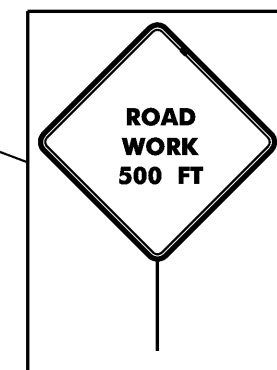
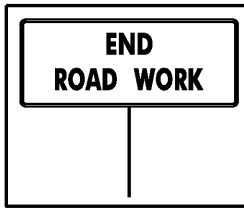
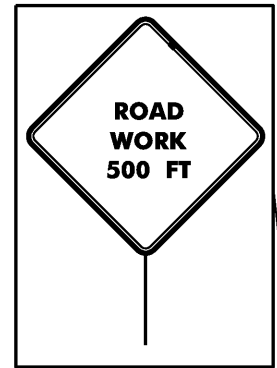

- ⊗ ⊗ TRAFFIC DRUMS (REFLECTORIZED)
- ▬ TEMPORARY TRAFFIC BARRIER
- - - - TEMPORARY BRIDGE RAILING

BRIDGE 19 TRAFFIC CONTROL

PROJECT NAME:	CHITTENDEN	PLOT DATE:	14-AUG-2009
PROJECT NUMBER:	STP 1443(45)	DRAWN BY:	STR
FILE NAME:	96J236\str\sj236trf.dgn	IPARM NAME:	sj236+fl.i
PROJECT MANAGER:	C. CARLSON	SHEET 31	OF 81
DESIGNED BY:	K. UPMAL		

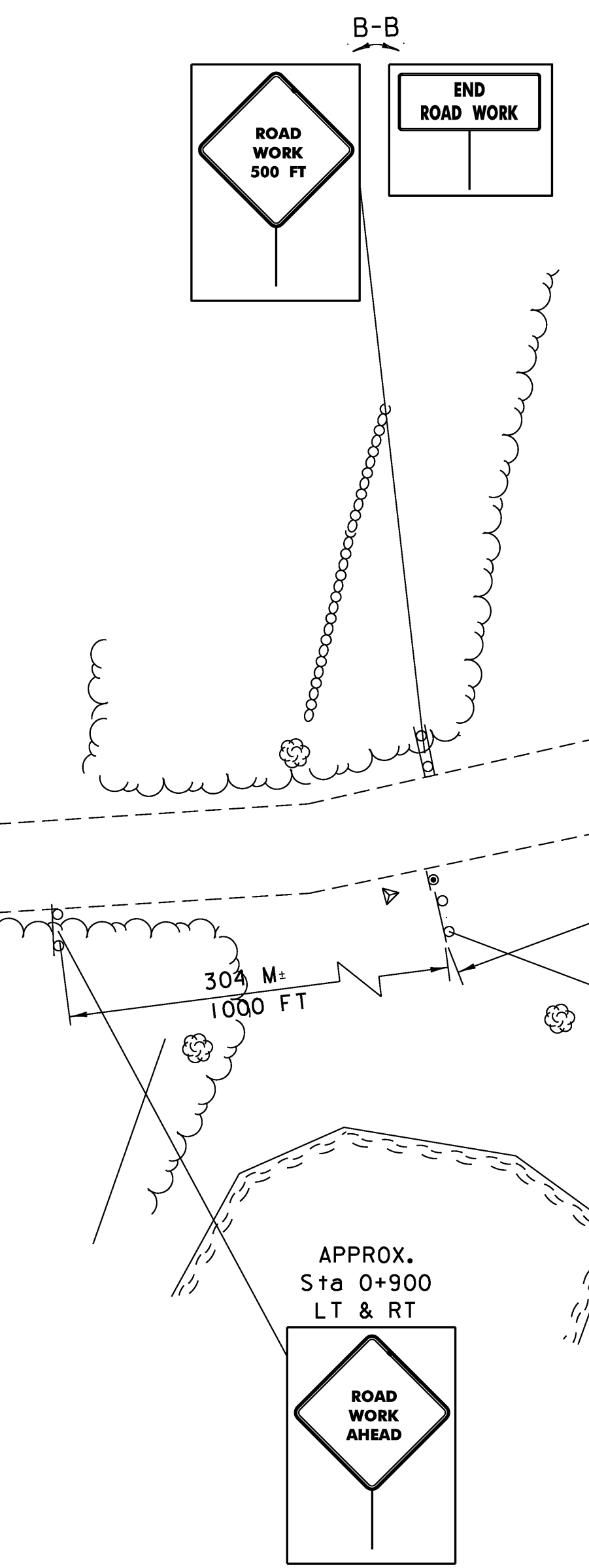
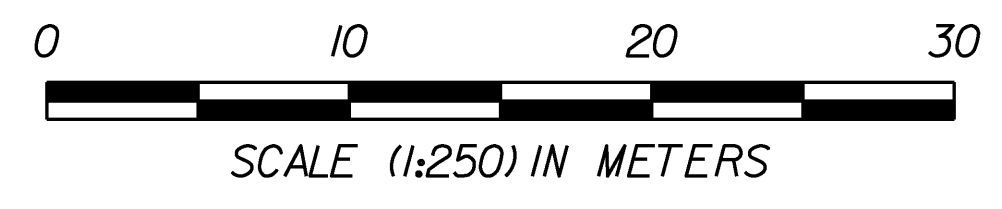

152 M =
500 FT

304 M =
1000 FT

APPROX.
Sta 0+900
LT & RT

S73°52'58.6"E

S16°24'02.2"E

S80°25'24.0"E

2000
(TYP)

7+000

I+080

I+100

I+040

I+020

I+000

I+020

I+040

I+060

I+080

I+100

7+050

7+070

7+090

7+110

7+130

7+150

7+170

7+190

7+000

7+020

7+040

7+060

7+080

7+100

7+120

7+140

7+160

7+180

7+200

7+000

7+020

7+040

7+060

7+080

7+100

7+120

7+140

7+160

7+180

7+200

7+000

7+020

7+040

7+060

7+080

7+100

7+120

7+140

7+160

7+180

7+200

7+000

7+020

7+040

7+060

7+080

7+100

7+120

7+140

7+160

7+180

7+200

7+000

7+020

7+040

7+060

7+080

7+100

7+120

7+140

7+160

7+180

7+200

7+000

7+020

7+040

7+060

7+080

7+100

7+120

7+140

7+160

7+180

7+200

7+000

7+020

7+040

7+060

7+080

7+100

7+120

7+140

7+160

7+180

7+200

7+000

7+020

7+040

7+060

7+080

7+100

7+120

7+140

7+160

7+180

7+200

7+000

7+020

7+040

7+060

7+080

7+100

7+120

7+140

7+160

7+180

7+200

7+000

7+020

7+040

7+060

7+080

7+100

7+120

7+140

7+160

7+180

7+200

7+000

7+020

7+040

7+060

7+080

7+100

7+120

7+140

7+160

7+180

7+200

7+000

7+020

7+040

7+060

7+080

7+100

7+120

7+140

7+160

7+180

7+200

7+000

7+020

7+040

7+060

7+080

7+100

7+120

7+140

7+160

7+180

7+200

7+000

7+020

7+040

7+060

7+080

7+100

7+120

7+140

7+160

7+180

7+200

7+000

7+020

7+040

7+060

7+080

7+100

7+120

7+140

7+160

7+180

7+200

7+000

7+020

7+040

7+060

7+080

7+100

7+120

7+140

7+160

7+180

7+200

7+000

7+020

7+040

7+060

7+080

7+100

7+120

7+140

7+160

7+180

7+200

7+000

7+020

7+040

7+060

7+080

7+100

7+120

7+140

7+160

7+180

7+200

7+000

7+020

7+040

7+060

7+080

7+100

7+120

7+140

7+160

7+180

7+200

7+000

7+020

7+040

7+060

7+080

7+100

7+120

7+140

7+160

7+180

7+200

7+000