

2 - 1" DIA ANCHOR "U" BOLTS
PER POST EACH WITH 4 NUTS AND
4 WASHERS (2 PLATE WASHERS AND
2 STANDARD WASHERS)

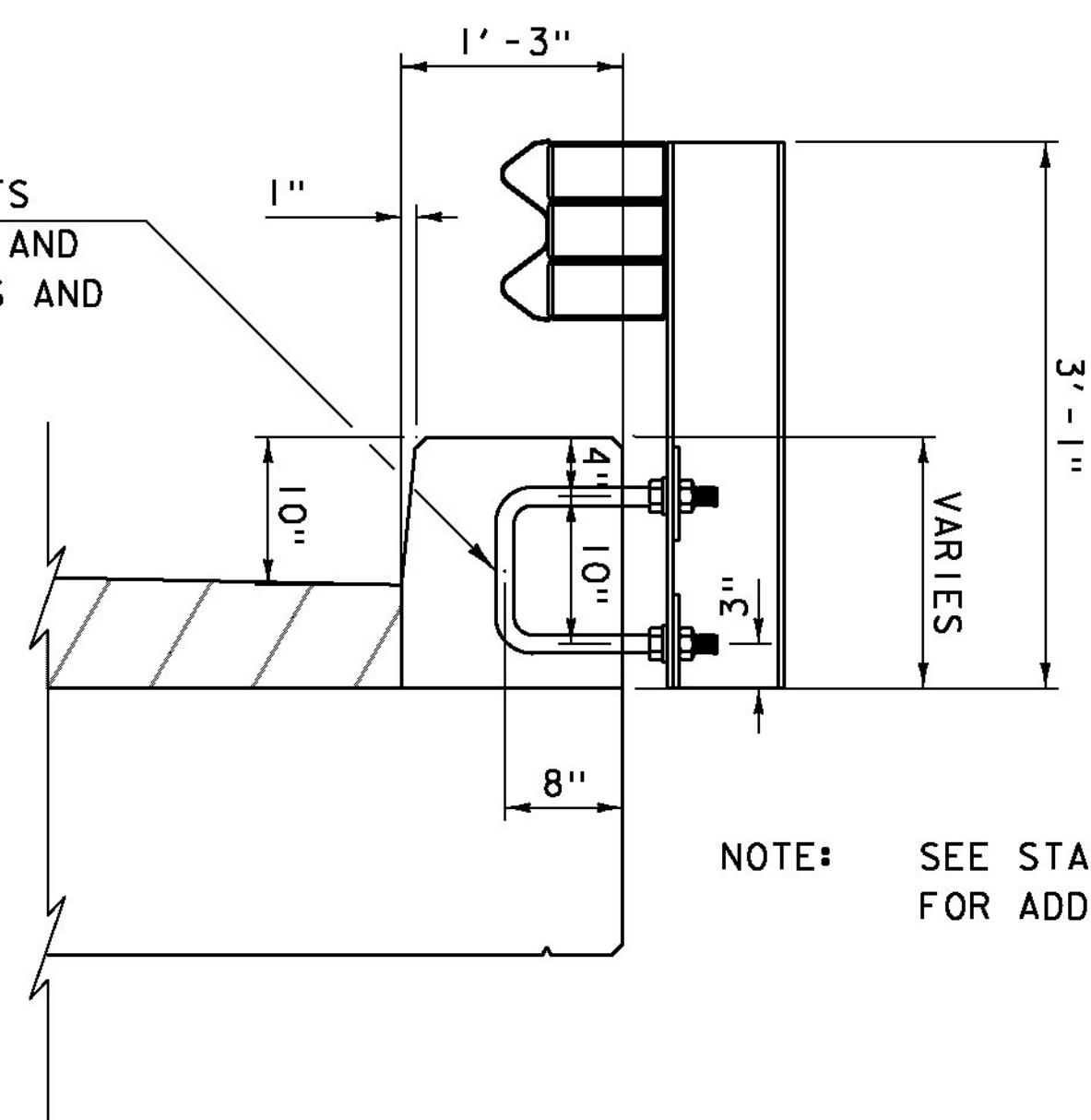

NOTE: SEE STANDARD S-367A
FOR ADDITIONAL DETAILS.

FASCIA MOUNTED RAIL DETAIL

NOT TO SCALE

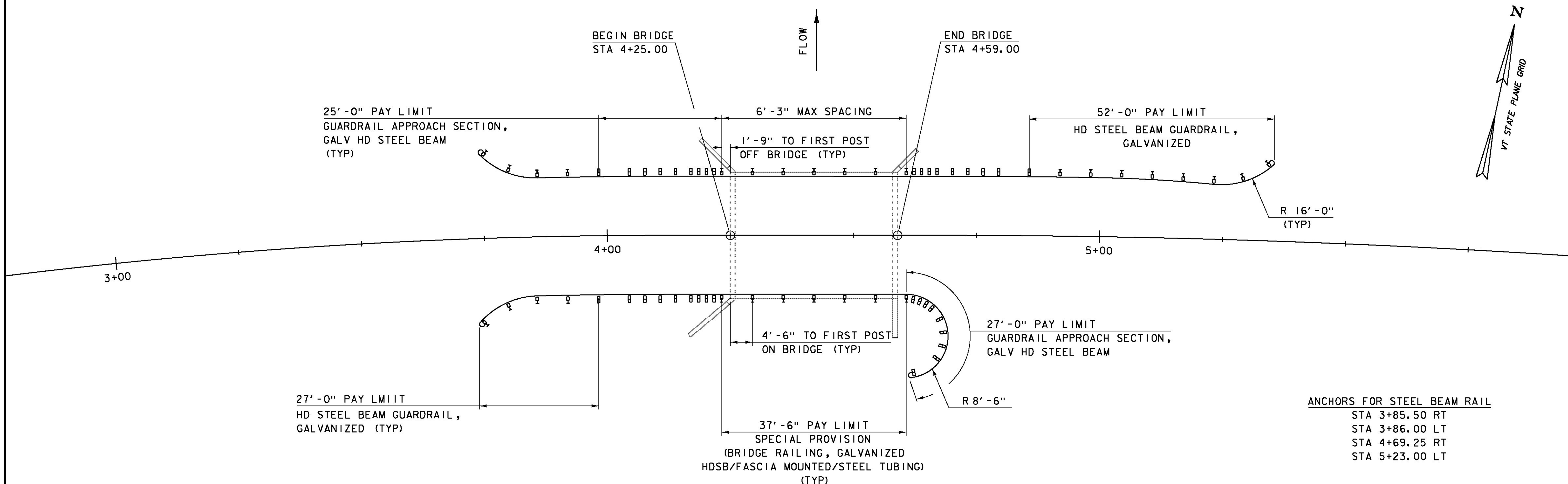

RAIL LAYOUT SHEET

SCALE 1" = 10'-0"
10 0 10

ANCHORS FOR STEEL BEAM RAIL

STA 3+85.50 RT
STA 3+86.00 LT
STA 4+69.25 RT
STA 5+23.00 LT

PROJECT NAME: WOODSTOCK
PROJECT NUMBER: BRO 1444(55)

FILE NAME: s95j294rail.dgn
PROJECT LEADER: K.M. HIGGINS
DESIGNED BY: J. SALVATORI
RAIL LAYOUT SHEET

PLOT DATE: 13-FEB-2013
DRAWN BY: J. SALVATORI
CHECKED BY: W. LAMMER
SHEET II OF 28