

TYPICAL PLAN VIEW

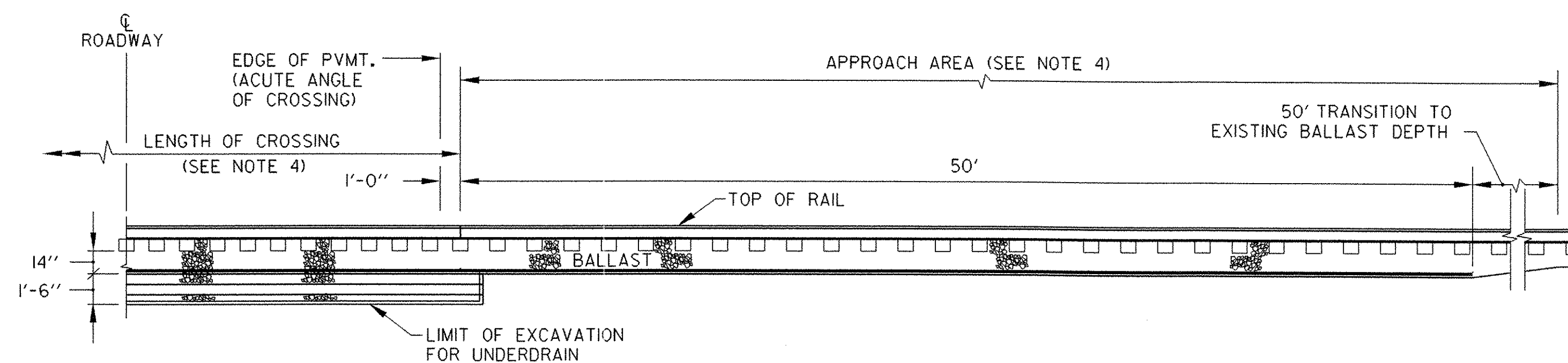

TYPICAL LONGITUDINAL SECTION

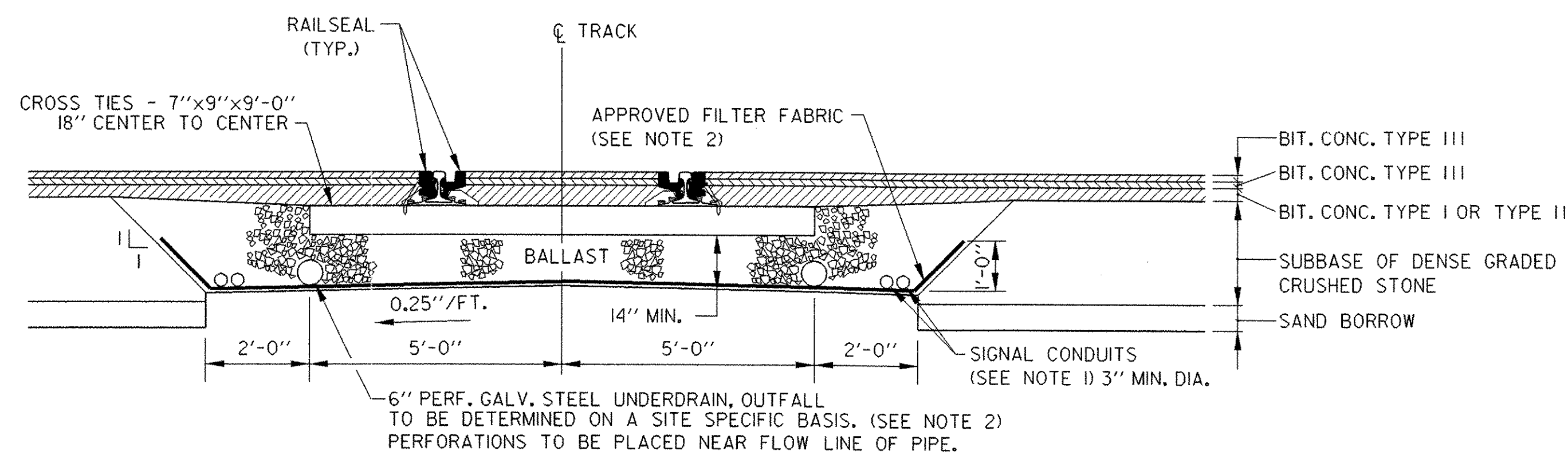

TYPICAL TRANSVERSE SECTION

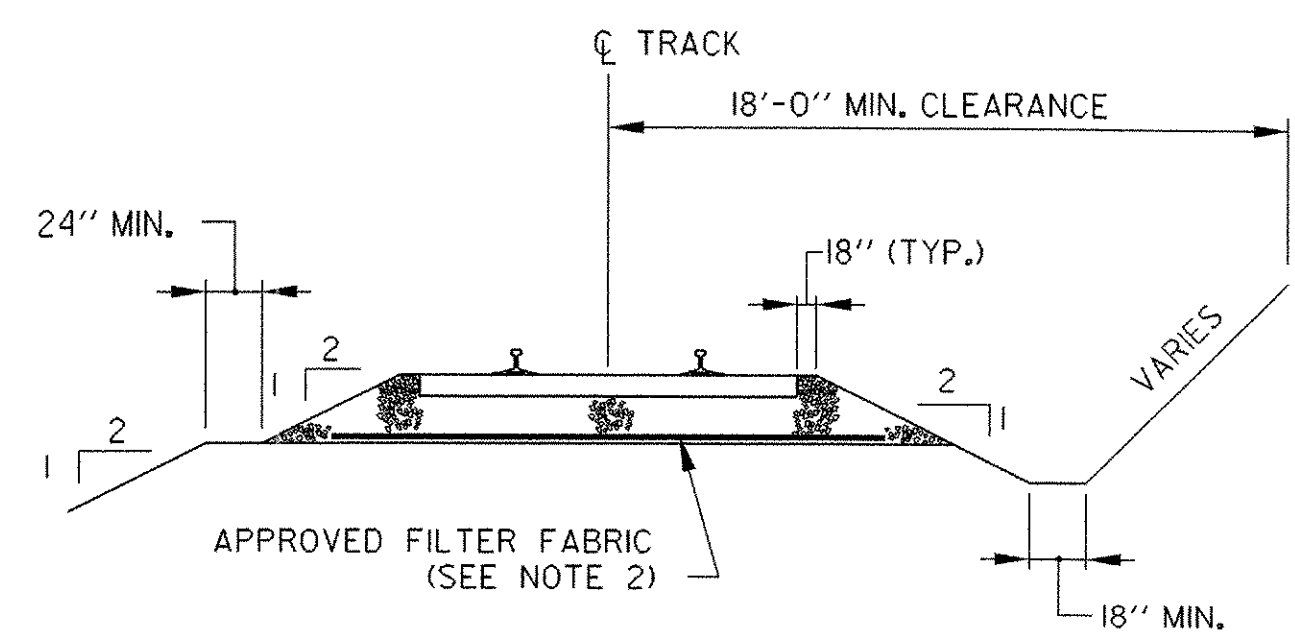

TYPICAL SECTION FOR APPROACH AREAS

GENERAL NOTES

- SIGNAL CONDUIT (SCHEDULE 80 PVC) TO BE INSTALLED WITH SECURED END CAPS IN LOCATIONS DIRECTED BY THE ENGINEER.
- THE OUTLET OF UNDERDRAIN AND GEOTEXTILE FABRIC SHALL BE DETERMINED UPON INSPECTION OF FIELD CONDITIONS BY THE ENGINEER.
- ALL RAIL JOINTS WITHIN THE CROSSING AREA AND 50'-0" BEYOND WILL BE CROPPED AND WELDED IN ACCORDANCE WITH THE LATEST REVISION OF A.R.E.M.A. SPECIFICATIONS AT AN OFF-SITE ELECTRIC WELDING PLANT. WELDING CAN BE DONE IN FIELD UTILIZING THERMITE WELDING WITH ADVANCE APPROVAL FROM THE AGENCY. WELDED JOINTS SHALL BE GROUND TO CONFORM TO THE SHAPE OF THE RAIL ON GAUGE AND FIELD SIDES.
- NEW 7"x9"x9'-0" AND 7"x9"x8'-6" TIES SHALL BE USED IN CROSSING AREA AS SHOWN. TIES IN APPROACH AREAS SHALL BE REPLACED AS RECOMMENDED BY THE RAILROAD AND APPROVED BY THE ENGINEER.
- TIE PLATES SHALL BE NEW 14 INCH PLATES MANUFACTURED FOR THE RAIL USED. PLATES SHALL BE INSPECTED AND APPROVED BY THE RAILROAD AND THE ENGINEER. RAIL FASTENERS SHALL BE EITHER CUT TRACK SPIKES OR PANDROL TYPE CLIPS AND LOCK SPIKES. SPECIFIC RAIL FASTENING SYSTEM SHALL BE RECOMMENDED BY THE RAILROAD AND APPROVED BY THE STATE OF VERMONT AGENCY OF TRANSPORTATION DURING FINAL DESIGN.
- BALLAST IN APPROACH AREAS SHALL EXTEND 18" BEYOND END OF TIES AND SLOPED 1:2 TO THE ROADBED. (SEE DETAIL)
- RAIL WEIGHT TO BE 115 LB. RE THROUGH CROSSING. DEVIATIONS FROM THIS ARE TO BE APPROVED BY VTRANS RAIL OPERATIONS AND VTRANS GRADE CROSSING ENGINEER.
- TYPE AND DESIGN OF RAILSEAL SHALL RECEIVE APPROVAL FROM THE VTRANS GRADE CROSSING ENGINEER.
- MANUFACTURERS SPECIFICATIONS SHALL BE FOLLOWED FOR THE INSTALLATION OF RAILSEAL.
- INSULATED JOINTS WILL BE REQUIRED FOR TYPE "C" TRACK CIRCUITS (CIRCUITS WITHOUT MOTION DETECTOR OR PREDICTOR SYSTEMS). IF INSULATED JOINTS ARE USED MAXIMUM STAGGER BETWEEN RAIL JOINTS SHALL BE 4'-6", MINIMUM SHALL BE 3'-6". IF INSULATED JOINTS ARE USED, INSTALL ONE ADDITIONAL NEW RAIL UP TO 39'-0" IN LENGTH BEYOND INSULATED JOINT.
- BITUMINOUS CONCRETE PAVEMENT SHALL BE INSTALLED WITH PAVING MACHINE WITH MAXIMUM 3" LIFTS (UNLESS OTHERWISE DIRECTED BY THE ENGINEER) AND SHALL BE LAID PARALLEL TO CROSSING TO MINIMIZE APPROACH SETTLEMENT.
- IF EXISTING TRACK IS CONTINUOUS WELDED RAIL, JOINT SHALL BE FIELD WELDED OR BOLTED AS SHOWN ON THE PLANS.
- REFER TO VTRANS STD. E-190 FOR PLACEMENT OF SIGNS AND PAVEMENT MARKINGS.

DETAILS ARE NOT DRAWN TO SCALE AND DIMENSIONS SHOWN IN ENGLISH UNITS

SHEET NAME: RAILROAD-HIGHWAY CROSSING DETAILS	
PROJECT NAME: LEICESTER	HIGHWAY NO.: TH 1
PROJECT NUMBER: BRF 0160(3)S	BRIDGE NO.: 6
	OVER: OTTER CREEK
FILE NAME: 95J288\Structures\sj288rrx.dgn	PLT DATE: 17-AUG-2005
PROJECT MANAGER: R. R. WHITCOMB	DRAWN BY: G. ROY
DESIGNED BY: C. CARLSON	IPARM NAME: sj288rrx.1
BRIDGE SHEET NUMBER:	SHEET 38a OF 90