

ABUTMENT 1 BEARINGS

BEARING	GUIDE ANGLE
1	NONE
2	96° - 19'
3	92° - 59'
4	NONE

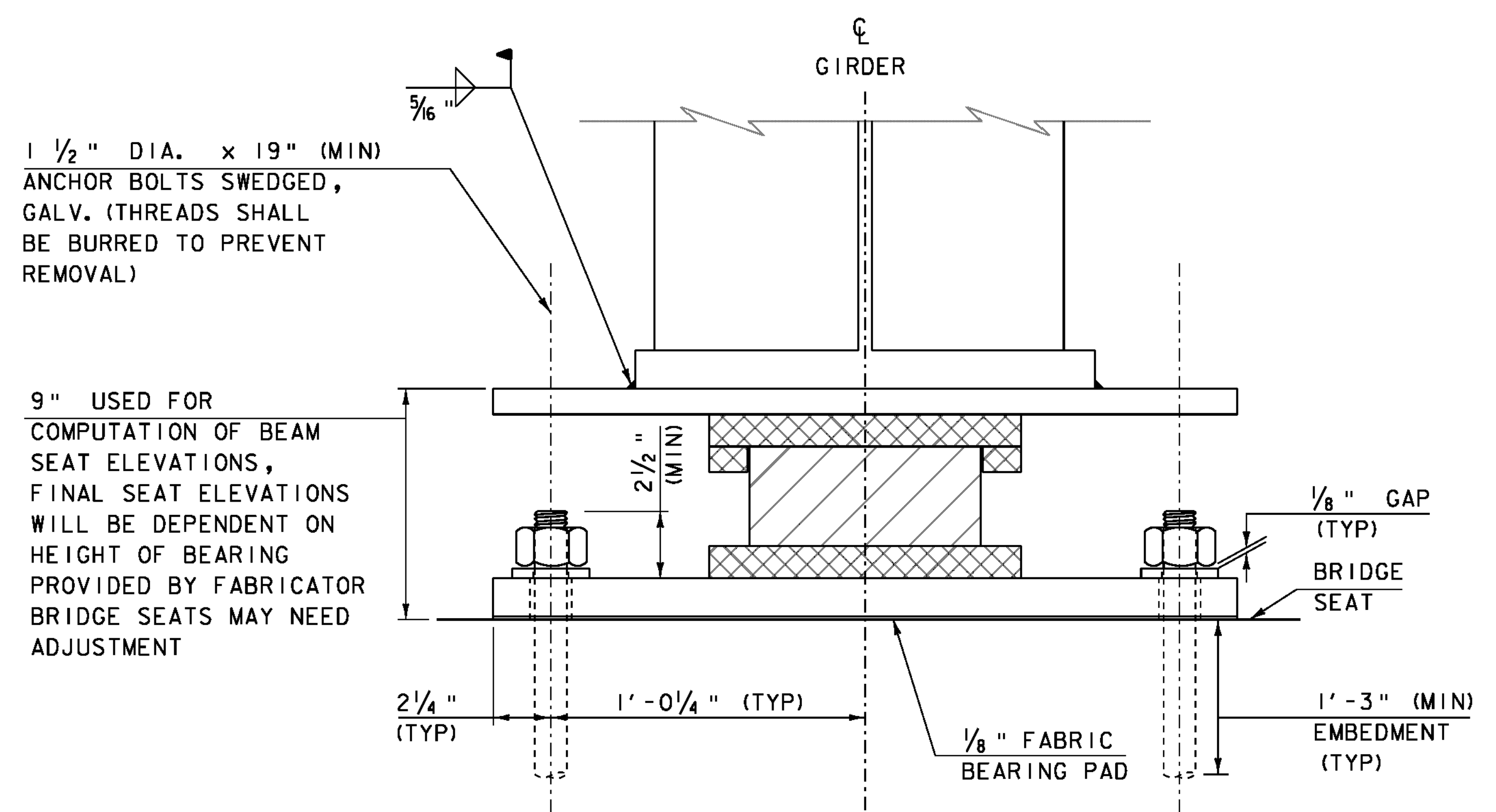
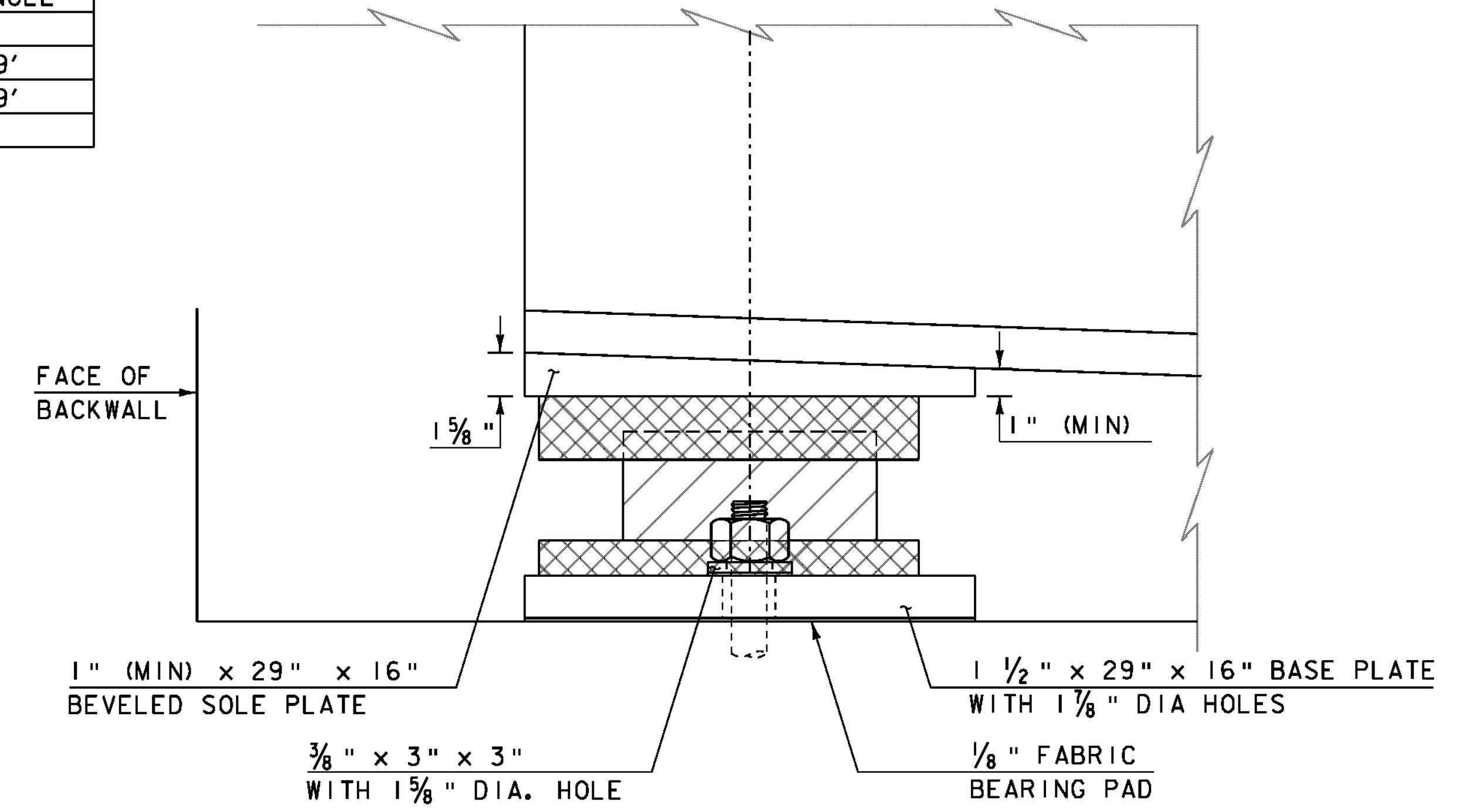
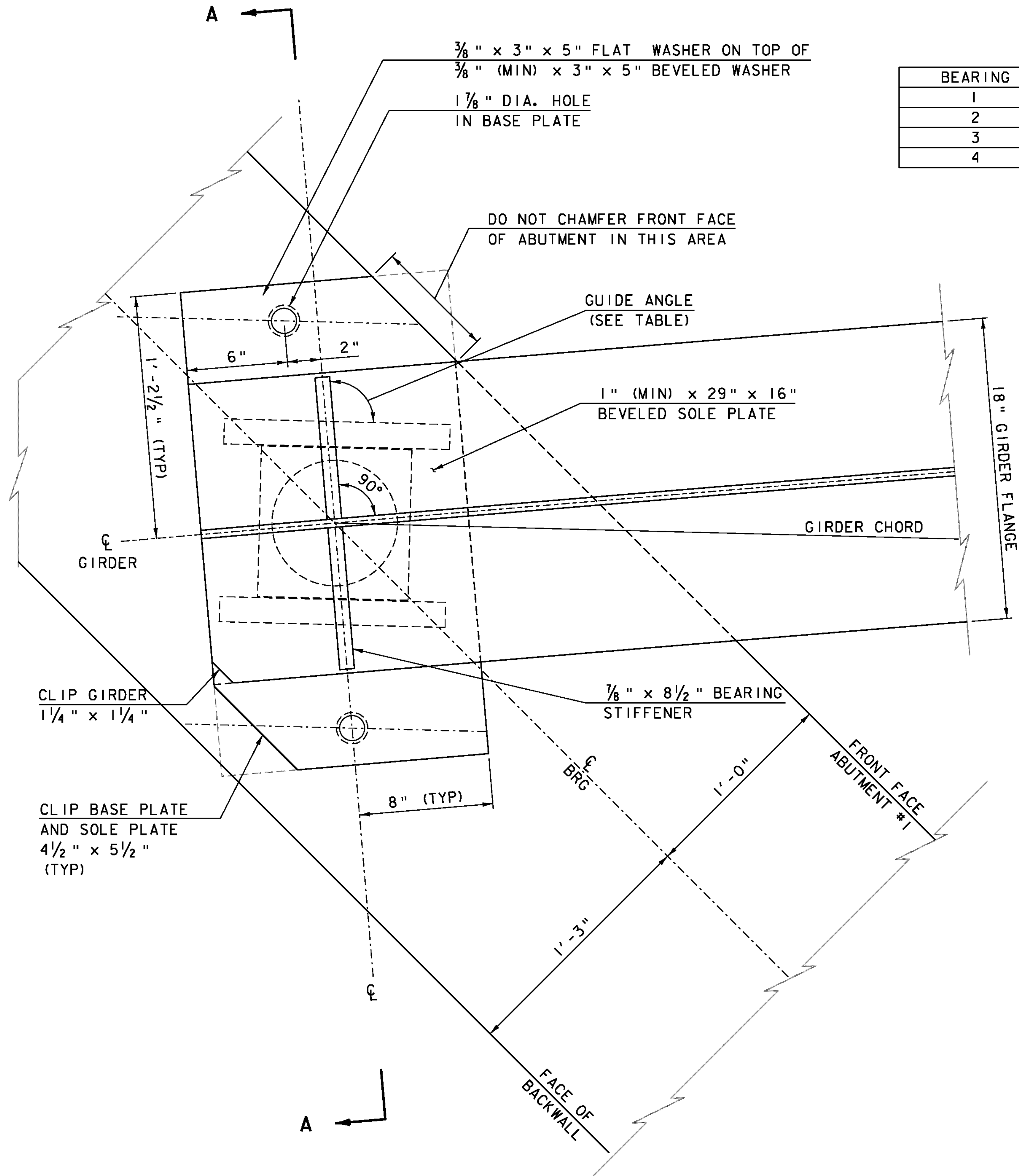

NOTES:

1. THE HATCHED COMPONENTS OF THE POT BEARINGS ARE SHOWN FOR REPRESENTATIVE PURPOSES ONLY. THE ACTUAL CONFIGURATION OF THE COMPONENTS WILL BE DEPENDENT UPON THE BEARING FABRICATOR.
2. SEE BEARING DETAILS-1 SHEET FOR ADDITIONAL BEARING NOTES.

PROJECT NAME: SPRINGFIELD
PROJECT NUMBER: BRO 1442(26)

FILE NAME: s95j282sup.dgn
PROJECT LEADER: K. HIGGINS
DESIGNED BY: J. LACROIX
BEARING DETAILS - 2

PLOT DATE: 30-AUG-2011
DRAWN BY: R. PELLETT
CHECKED BY: J. LACROIX
SHEET 23 OF 52