



Production Joint Welding Procedure Specification (D1.5-02)

Procedure No: A-(MC)GSV-01 Date Issued: 9-29-04 Revision No: 0 Rev. Date: _____

Contractor (Fabricator) D. S. Brown Company Prepared by: James R. Connor, Quality Assurance Manager

1. Non-Fracture Critical Fracture Critical WPS Expiration Date: _____
2. Qualified in accordance with: AWS D1.5- 2002 (5.12.1)
 Referenced PQR No(s). PQR-(MC)GMAW-01(04) , _____ , _____
 Referenced FWST No(s). _____ , _____ , _____
3. Material specification(s) ASTM A709 Gr. 36, 50, 50W For DOT Approval
4. Material Thickness (es) Unlimited
5. Welding process GMAW
6. Manual , machine , or semiautomatic
7. Position(s) of welding 1G, 2G
8. Filler metal specification AWS A5.18
9. Filler metal class and brand name E70C-6M Corex Metal-Core Maxim
10. Flux class & brand N/A , Type N/A
11. Shielding gas 75% Ar / 25% CO2 Flow rate 45 CFH
12. Single pass Or multiple pass
13. Single arc Or multiple arc
14. Welding Current DCEP
15. Polarity Reverse
16. Welding progression stringers
17. Root treatment Clean to bright sound metal or per AWS D1.5 (3.2.1 & 3.11)
18. Postheat treatment N/A
19. Calculated Heat Input (KJ/In) Min 30.6 KJ/in Max 51.1 KJ/in
20. Electrode extension (electrical stickout) 3/4"

TRANS RECEIVED
 OK'D BY _____ OK'D BY Juc
 NOV 17 2004
 APPROVED ✓
 DATE 12/29/09

Weld size (in)	Pass No(s)	Electrode Size (in)	Welding Process Variables		Travel Speed (IPM)
			AMPS	VOLTS	
1/4"	1	.052"	265-320	31-34.5	13-16
5/16"	1-2	.052"	265-320	31-34.5	13-16
3/8"	1-3	.052"	265-320	31-34.5	13-16
1/2"	3-4	.052"	265-320	31-34.5	13-16
5/8"	4-6	.052"	265-320	31-34.5	13-16
3/4"	5-8	.052"	265-320	31-34.5	13-16

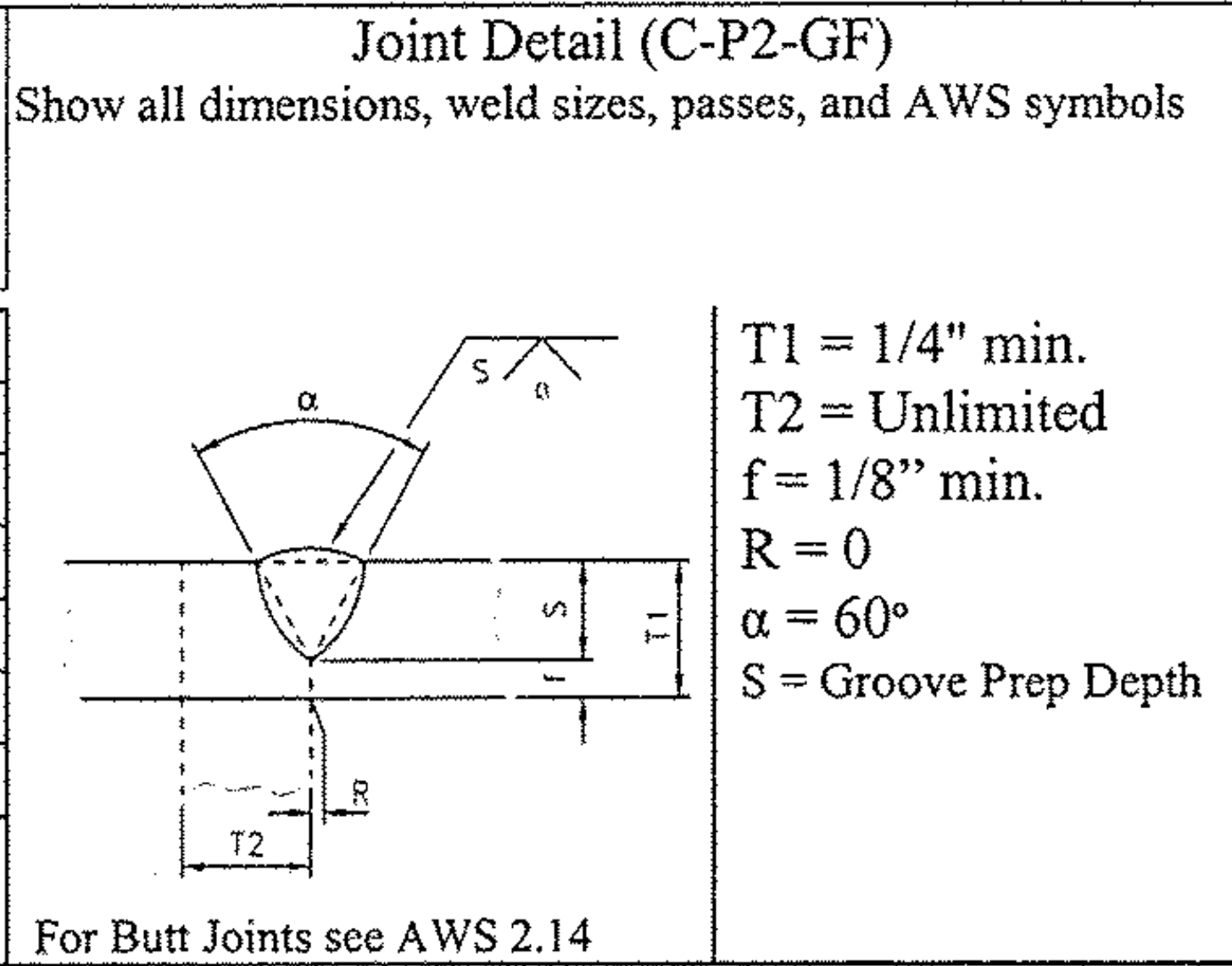

Prepared By: James R. Connor DSB QA Manager
 Project: TH 62 OVER WEST RIVER
 DSB Job: 27177-1011

Base Metal Thickness range	Minimum Preheat (°F)	Max Preheat & Interpass (°F)
≤ 3/4"	50°F	450°F
>3/4" to ≤1.5"	70°F	450°F
>1.5" to ≤2.5"	150°F	450°F
>2.5"	225°F	450°F

Note: When this procedure is used for A709Gr50W materials, it shall be limited to 5/16" single pass or material be coated.