

X1pa (PL 22)

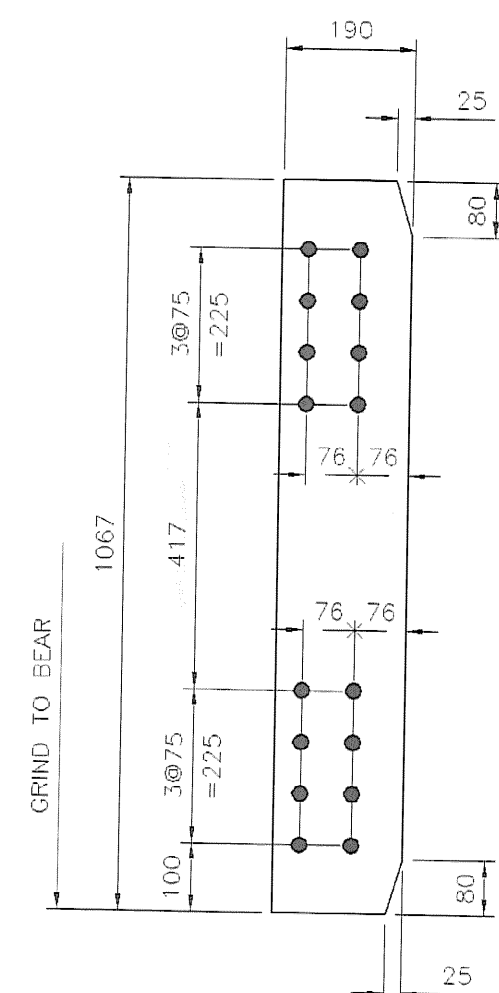

X1pb (PL 22)

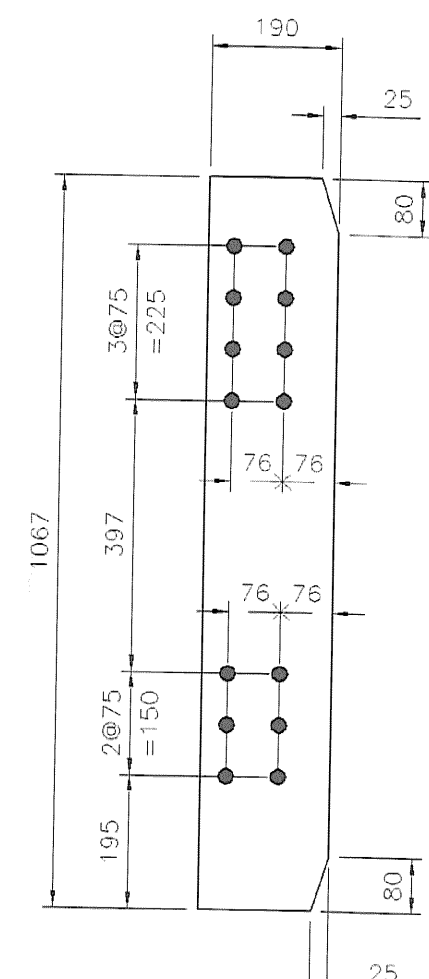

X1pc (PL 13)

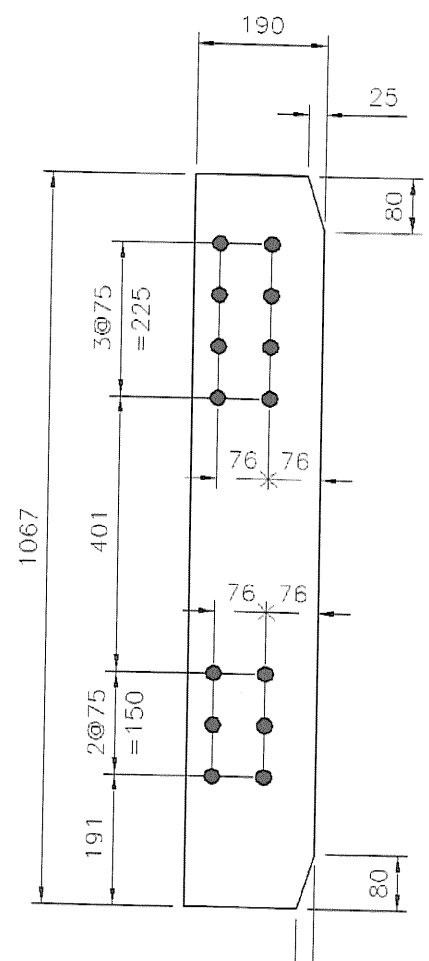

X1pd (PL 13)

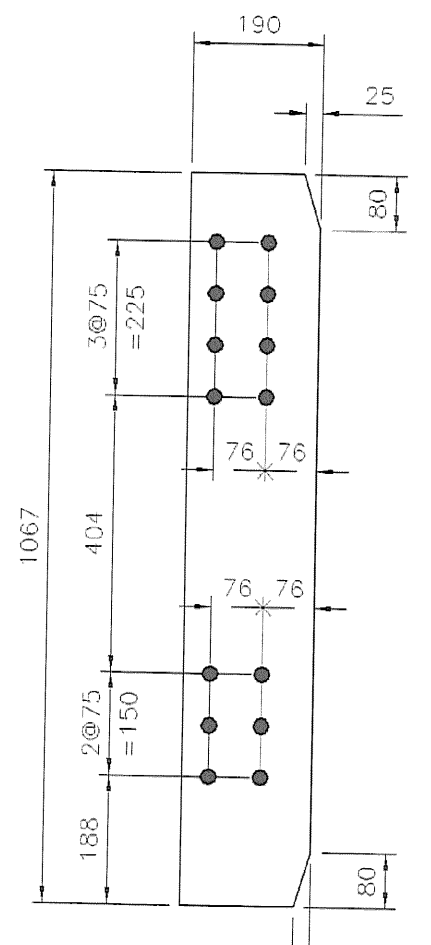

X1pe (PL 13)

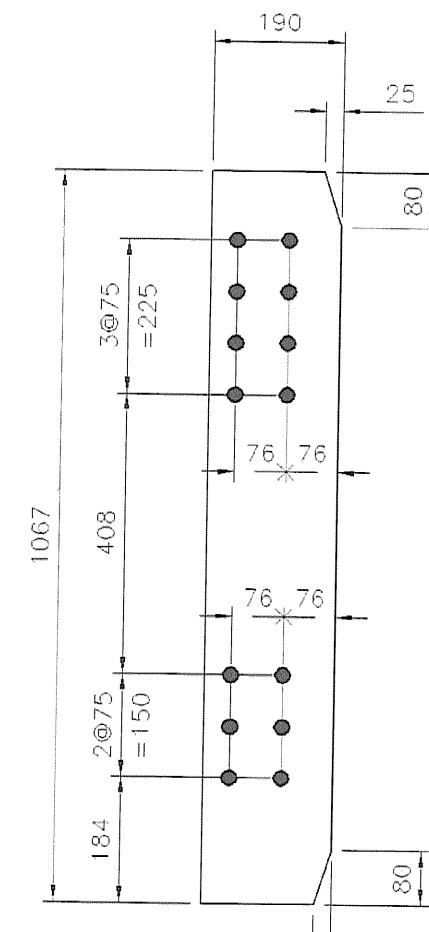

X1pf (PL 13)

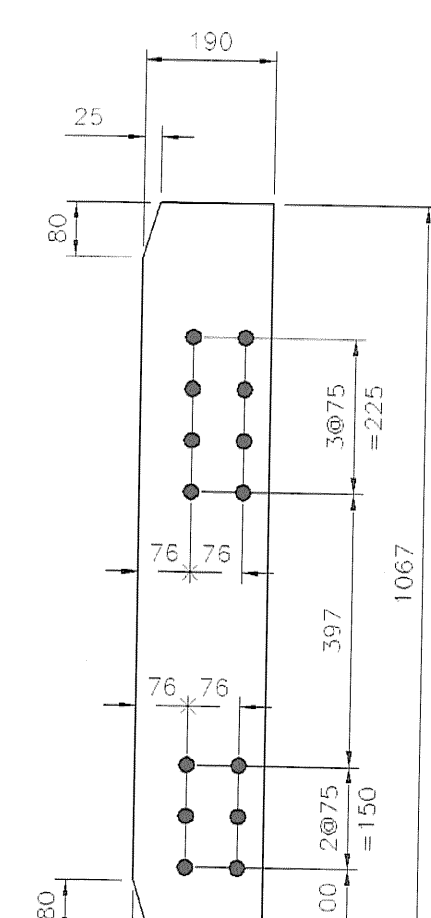

X1pg (PL 13)

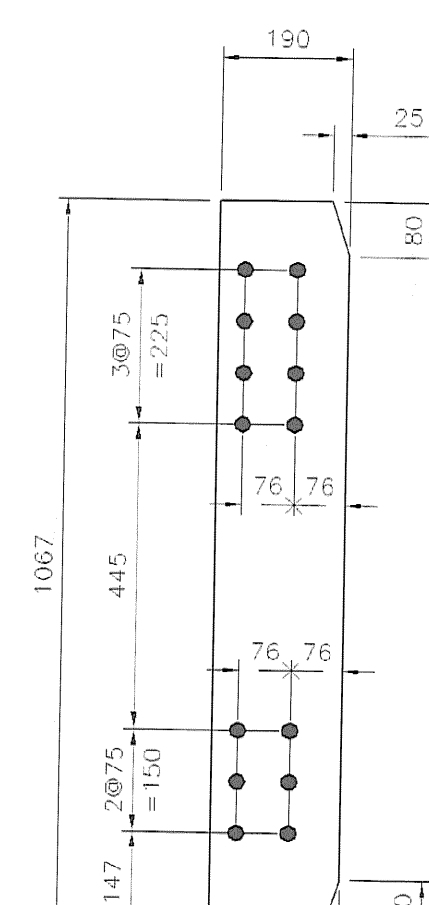

X1ph (PL 13)

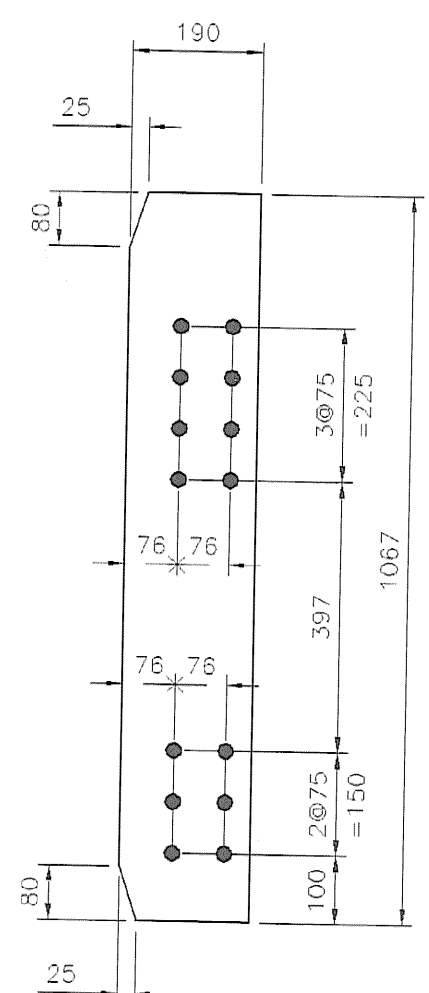

X1pn (PL 13)

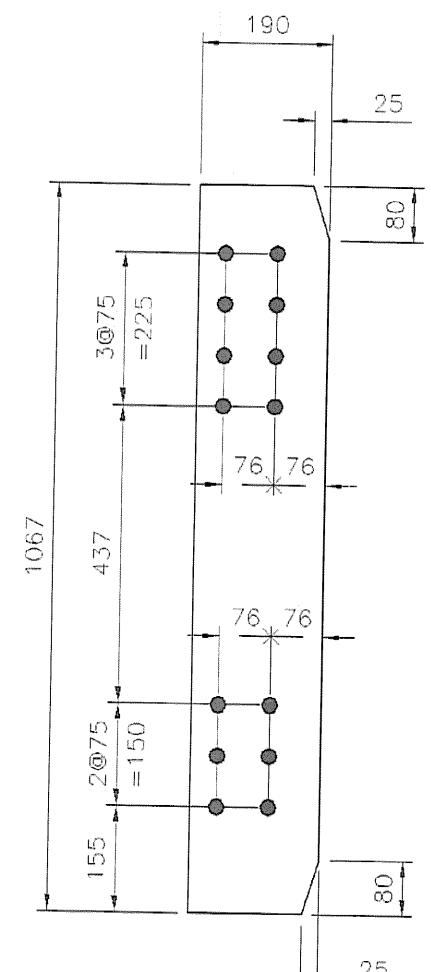

X1pp (PL 13)

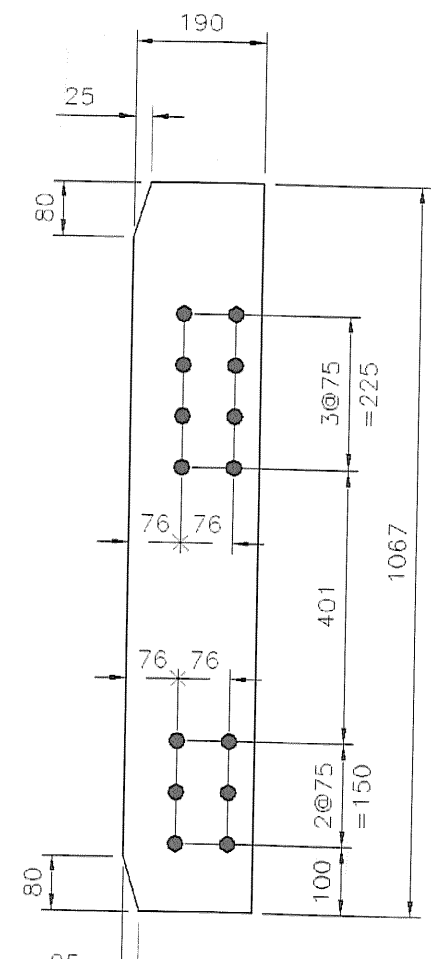

X1pr (PL 13)

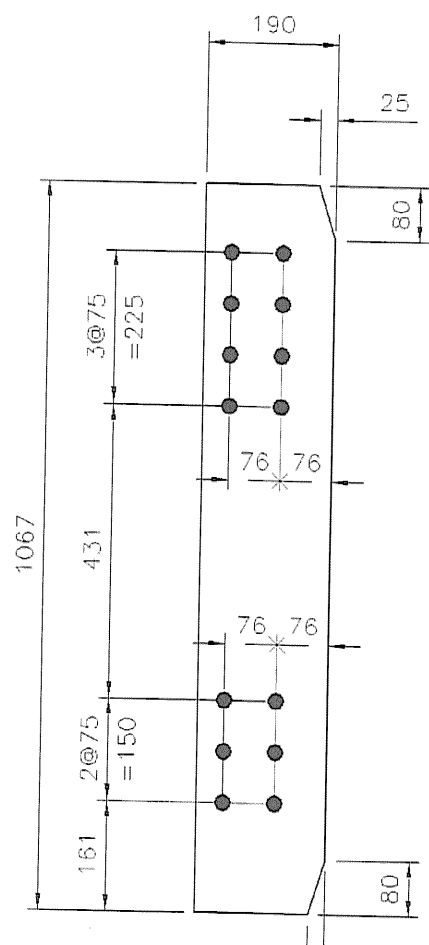

X1ps (PL 13)

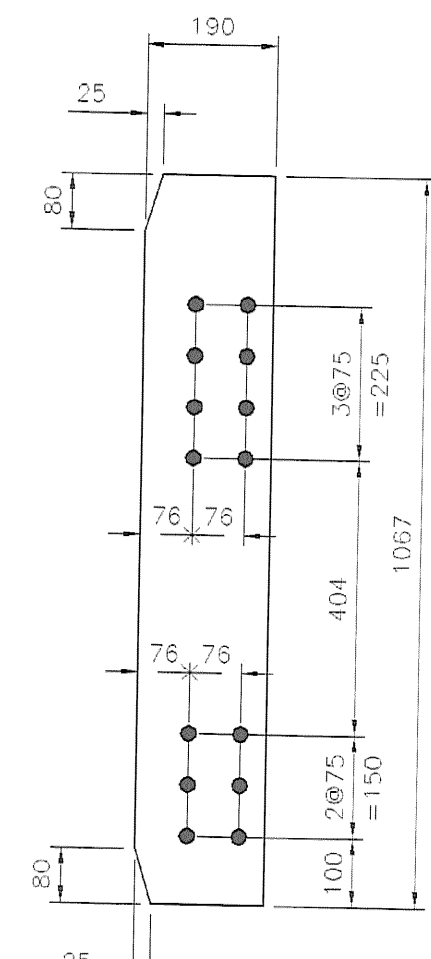

X1pt (PL 13)

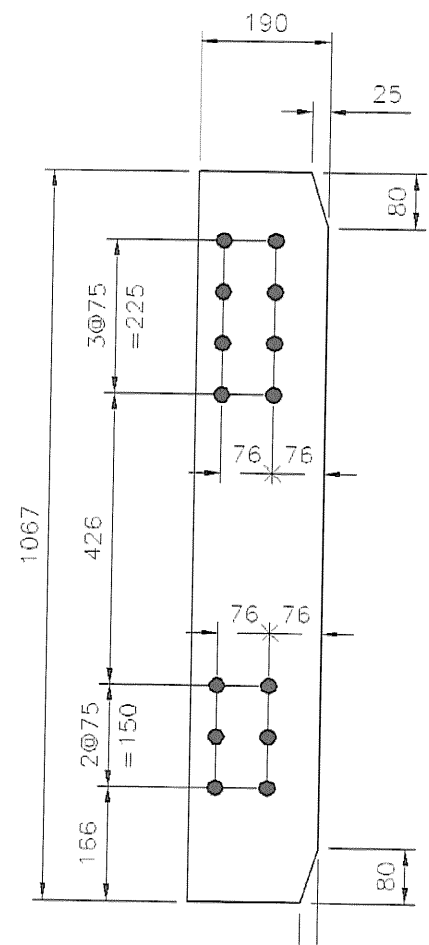

X1pv (PL 13)

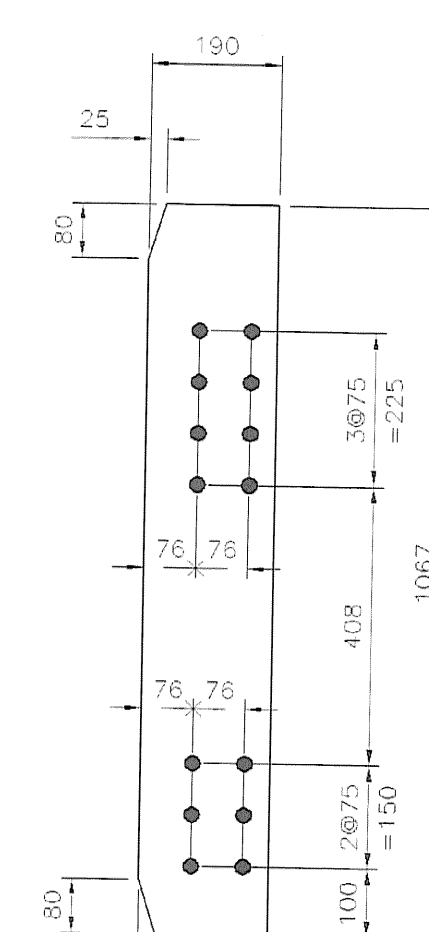

X1pw (PL 13)

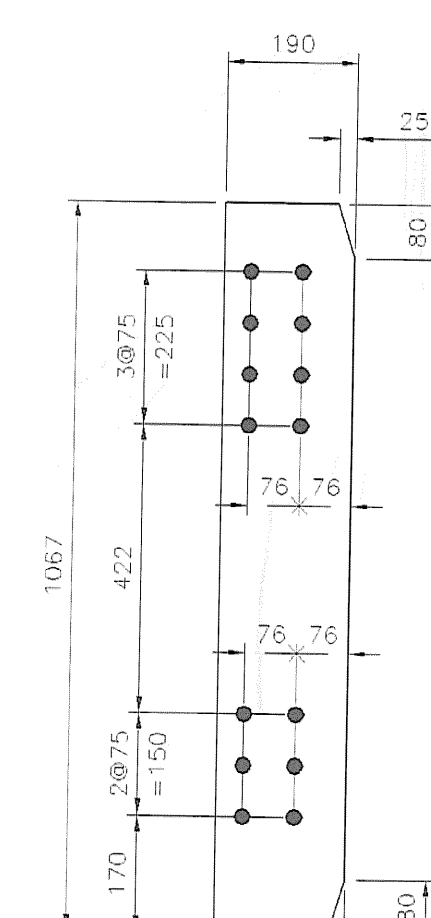

X1px (PL 13)

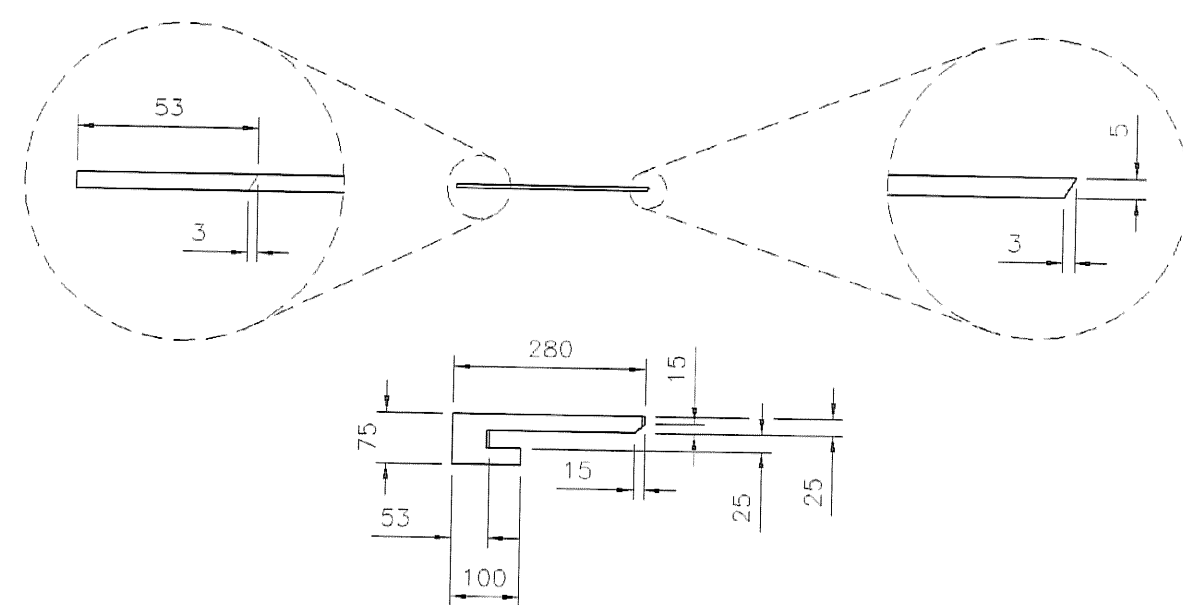

X1paa (PL 5)

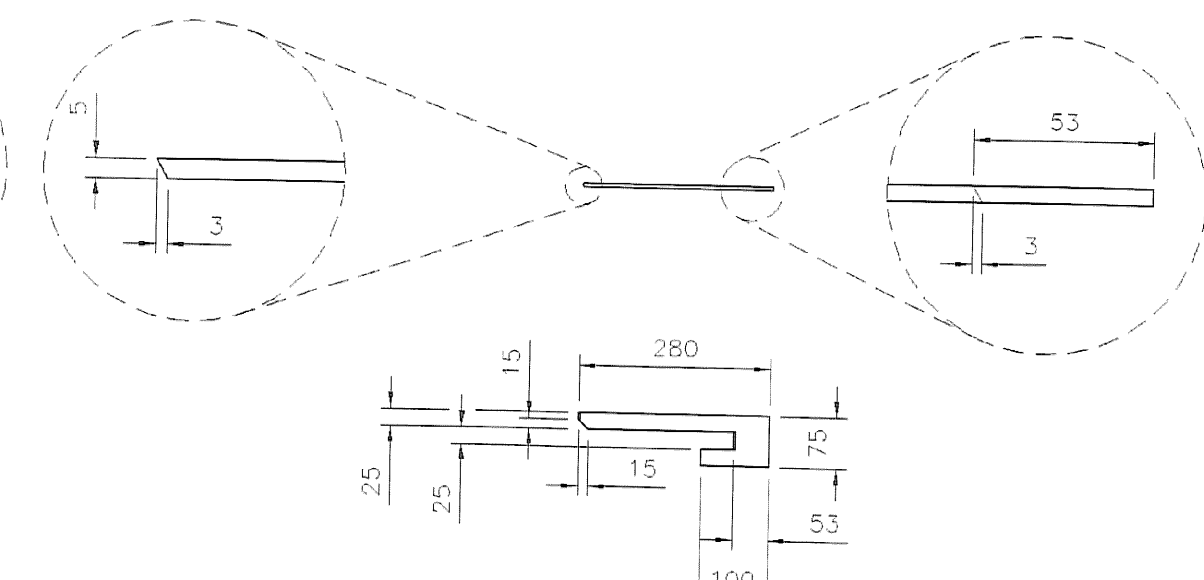

X1pab (PL 5)

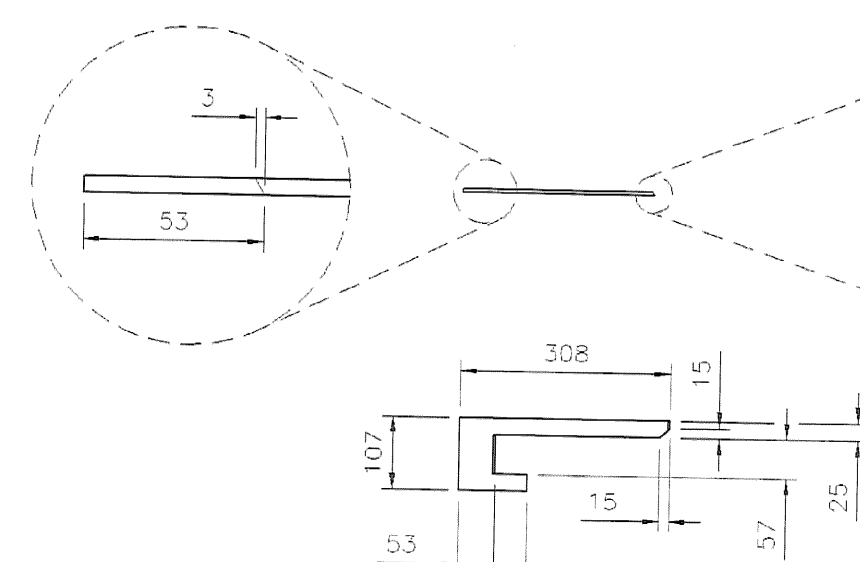

X1pac (PL 5)

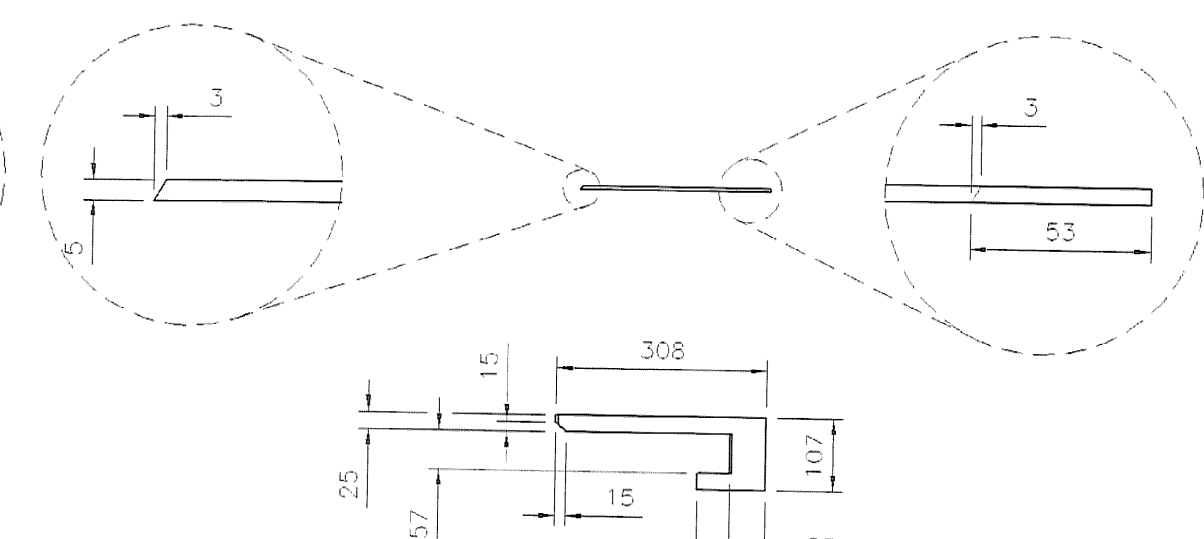

X1pad (PL 5)

ALL MATERIAL (EXCEPT BOLTS) TO BE ASTM: A709M-50W	
ALL WELDS TO BE MADE WITH ELECTRODES SERIES E70XX	
OPEN HOLES ARE FOR H.S. BOLTS AND ARE TO BE FREE OF BURRS AND SCALE	
BOLTS: 7/8" M16M TYPE III	OPEN HOLES: 24 UN PAINT: SEE GA-1
International Bridge & Iron Co. 90 Day Street Newington, CT 06111	
VERMONT DOT SUNDERLAND BRIDGE FED. AID PROJ. NO.: BR-0114 (2) CONTRACTOR: PETRICCA CONSTRUCTION CORP. ENGINEER: ROGER WHITCOMB	
Re Appr'd	Revised
DETAILS	
Drawn by: D.E.	Rev: 02/16/07
Checked by: G.D.	Rev: 02/27/07
Contract	Suffix
606	X1

RECEIVED
 CK'D BY: *OML* OK'D BY: *DAP*
 MAR 07 2007
 RESUBMIT: _____ APPROVED: *[Signature]*
 BY: *[Signature]* DATE: 3/20/07