

STEEL GRATE

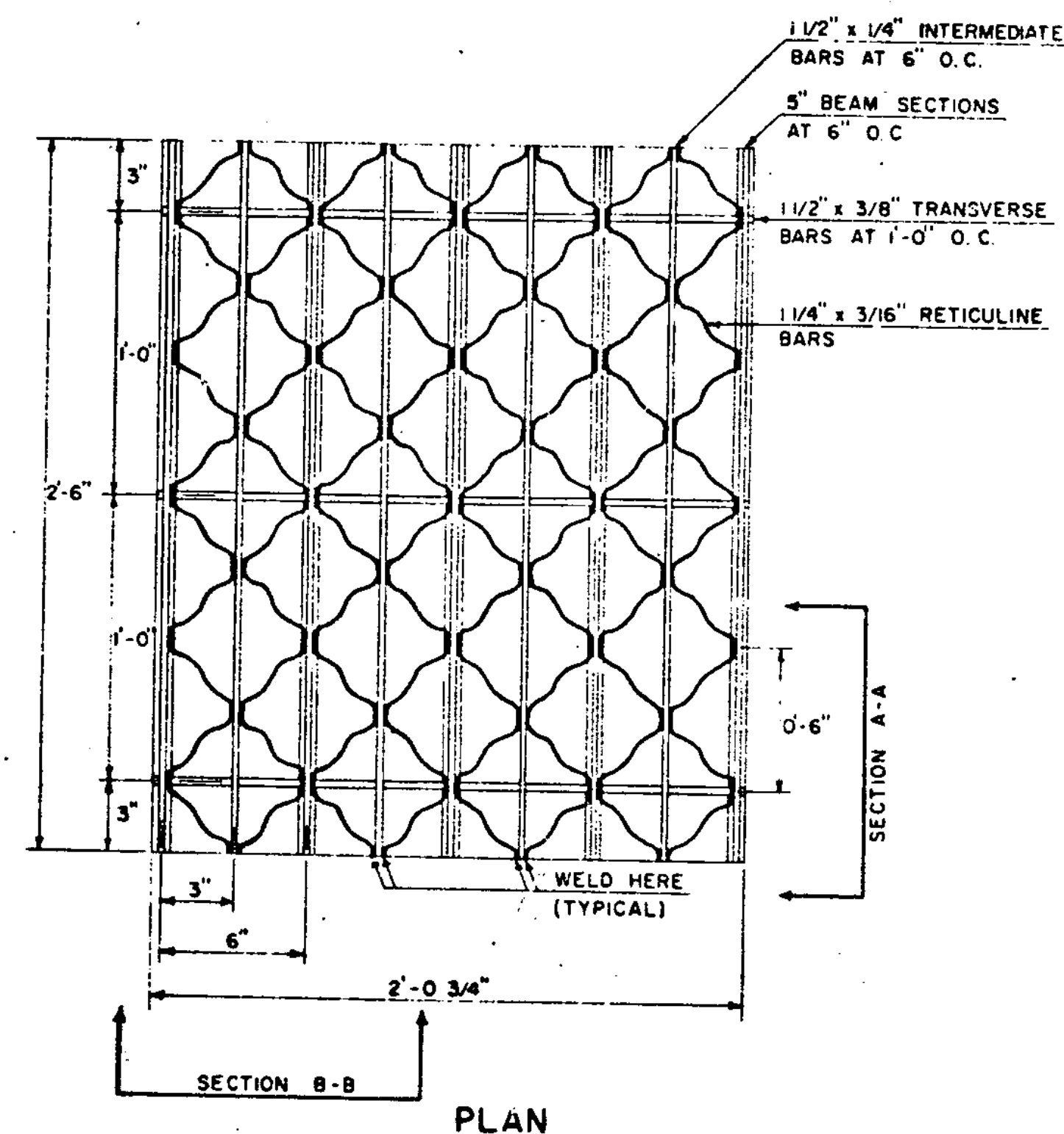

GRATE SIZE SINGLE 24 3/4" x 30"
DOUBLE 24 3/4" x 54"
WEIGHT 95 LBS OR MORE
GRATES SHALL BE CAPABLE OF SUPPORTING H-20 (32,000 LB AXLE LOAD) INCLUDING 30% IMPACT.

UNIT STRESSES (LBS PER SQ. IN.)	18,000	20,000
MAIN BAR PARALLEL TO TRAFFIC	H-20 45"	53"
MAIN BAR PERPENDICULAR TO TRAFFIC	H-20 39"	42"

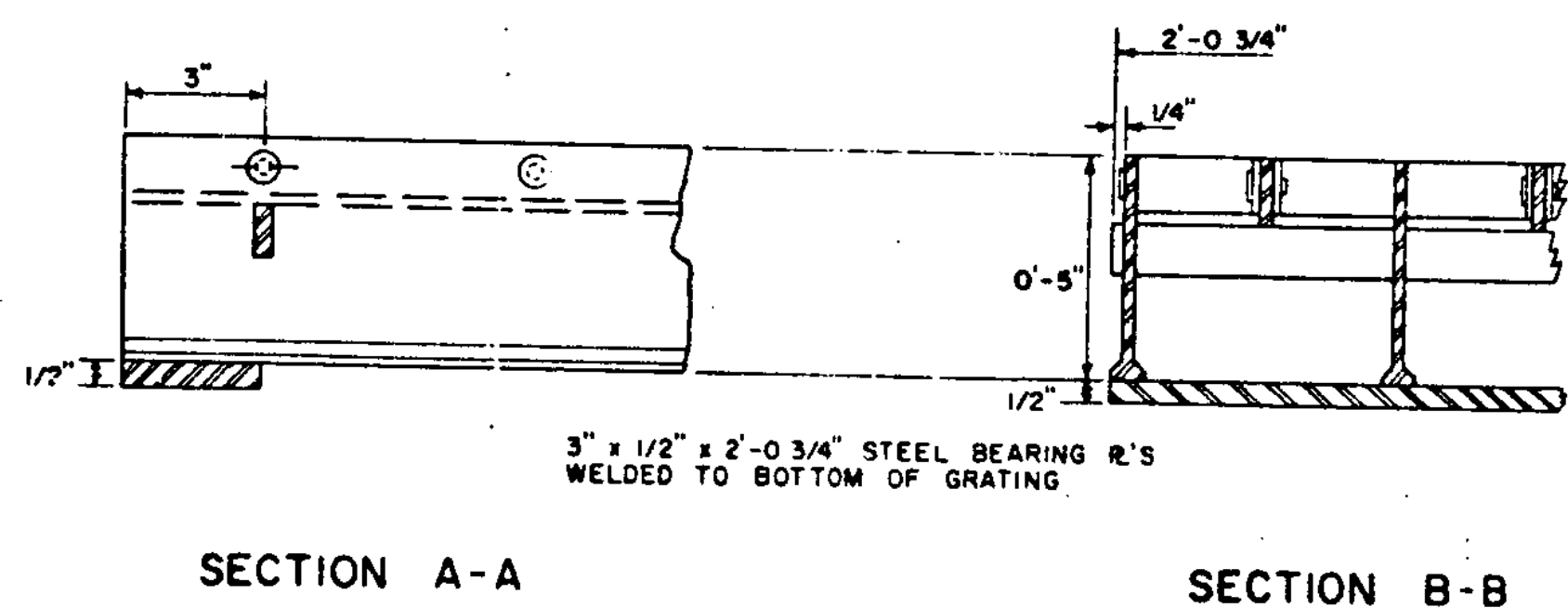

CAST IRON COVER WITH FRAME

BAR	NO.	LENGTH	SHAPE
B	4	3'-8"	STRAIGHT
C	6	3'-8"	STRAIGHT
D	4	3'-8"	STRAIGHT

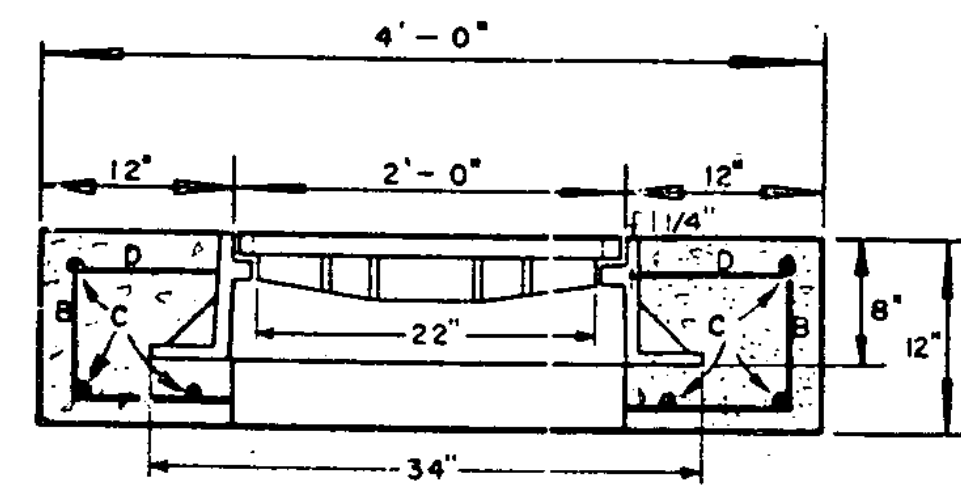

ELEVATION

ALL REINFORCING STEEL TO BE NO. 5 DEFORMED BARS

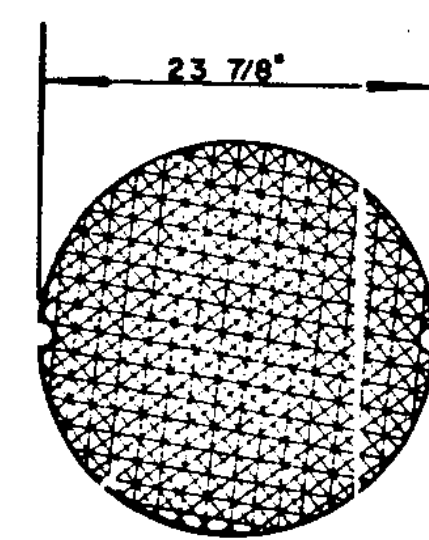

PLAN

CAST IRON GRATE WITH FRAME

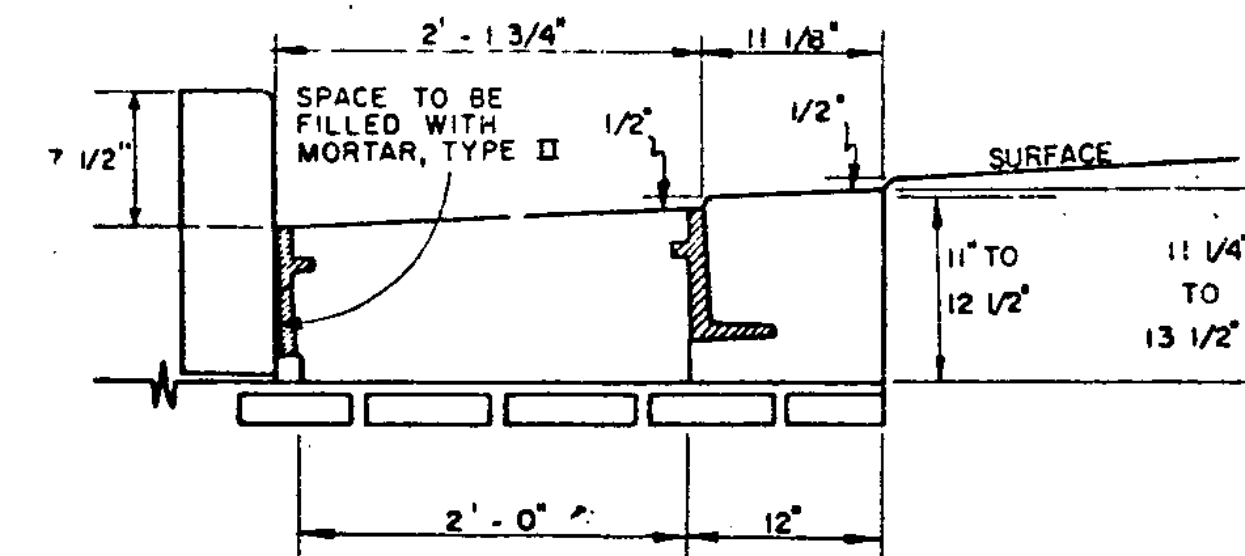

ELEVATION OF REINFORCED CONCRETE DROP INLET WITH VERTICAL GRANITE CURB AND 3 FLANGE CAST IRON FRAME FOR CAST IRON GRATE.

SEE STANDARD D-9 FOR CONCRETE VOLUME, REINFORCING STEEL SCHEDULE AND CURB JOINT DETAIL.

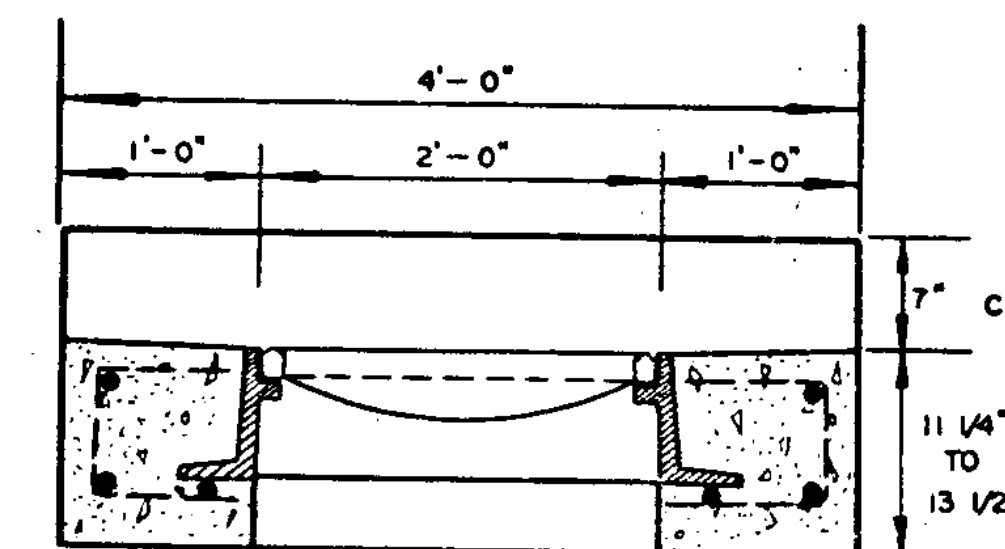

ELEVATION

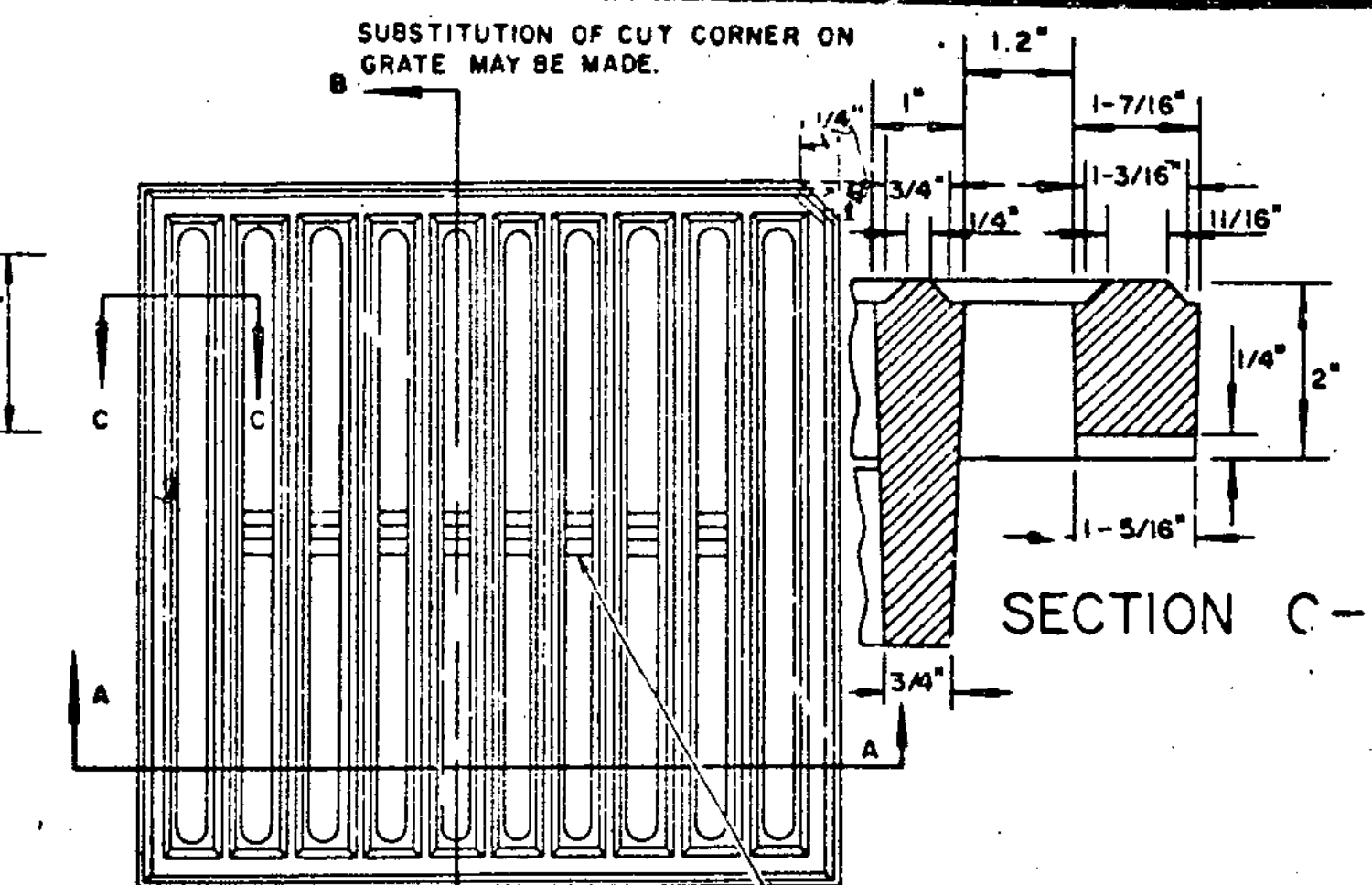

PLAN

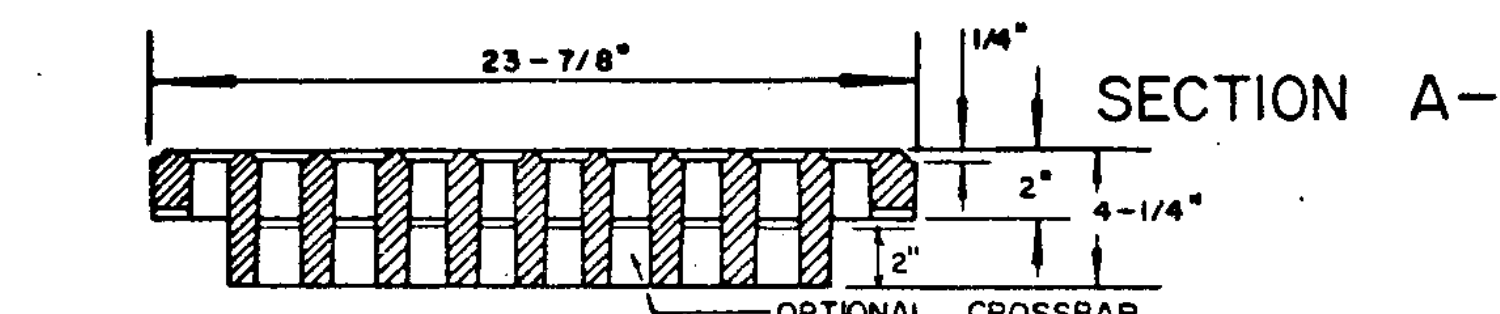

SECTION A-A

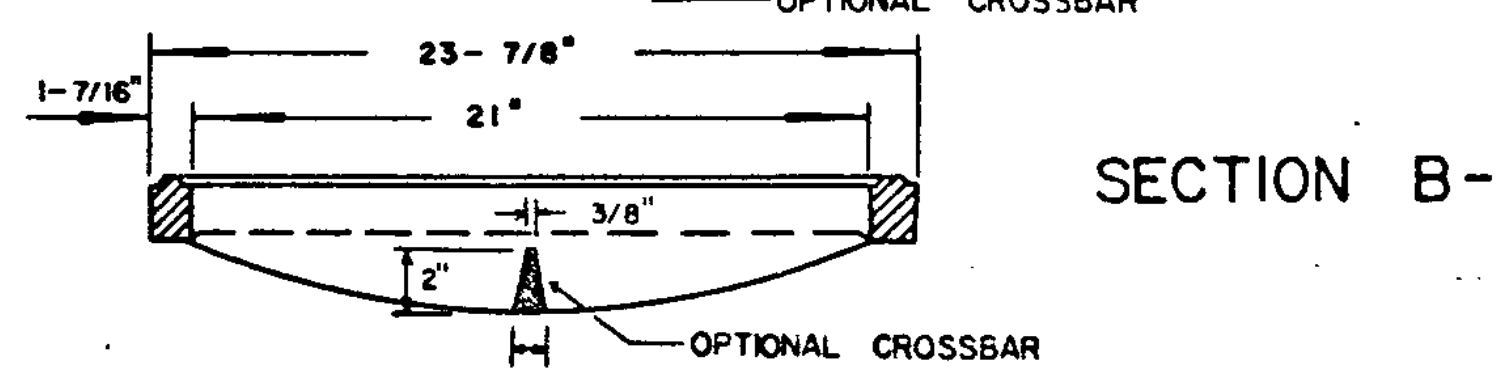

SECTION B-B

WEIGHT OF 3 FLANGED FRAME AND GRATE
GRATE 220 LBS
FRAME 260 LBS
TOTAL 480 LBS

CAST IRON GRATE, TYPE A

USE OF THE TYPE A GRATE IS PROHIBITED WHERE BICYCLE TRAFFIC IS EXPECTED.

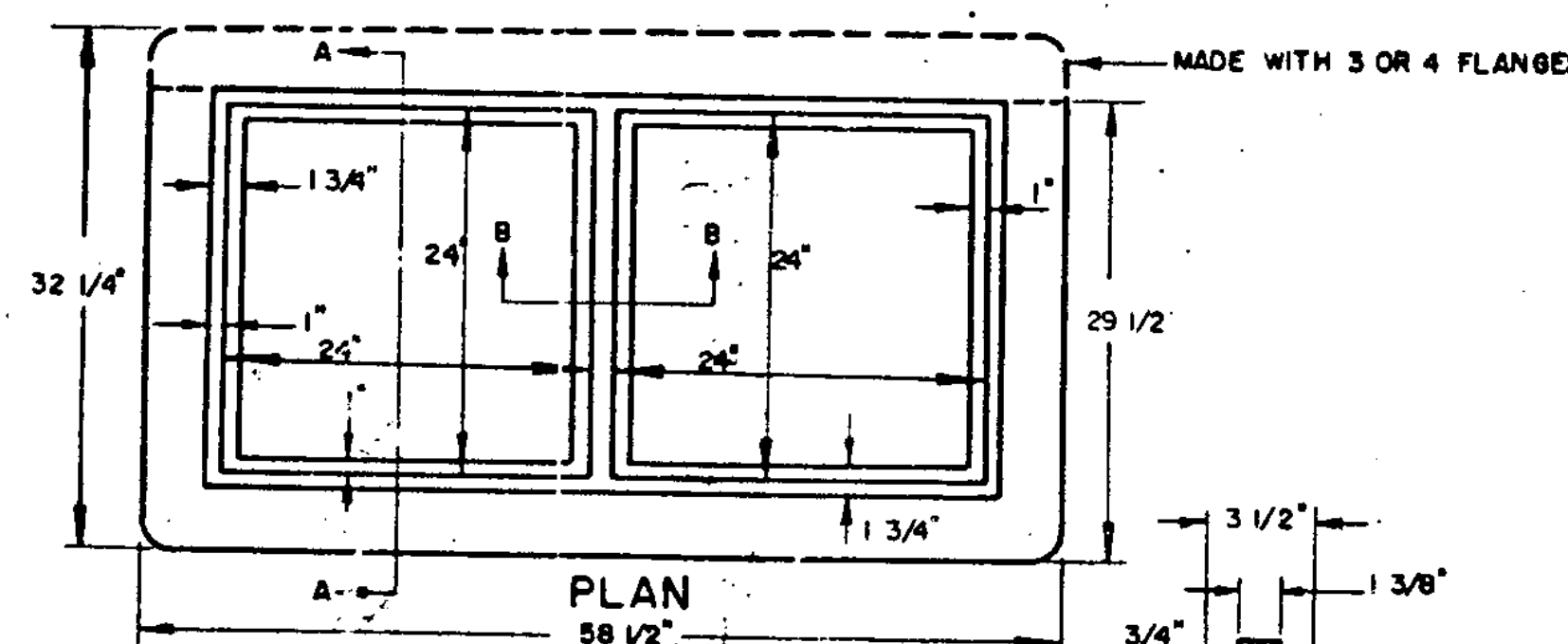

PLAN

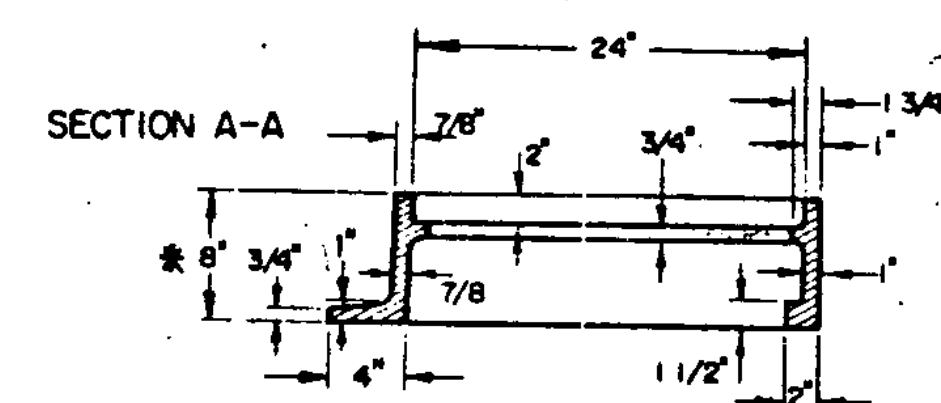

RECTANGULAR CAST IRON FRAME FOR TWO 24" SQUARE CAST IRON GRATES

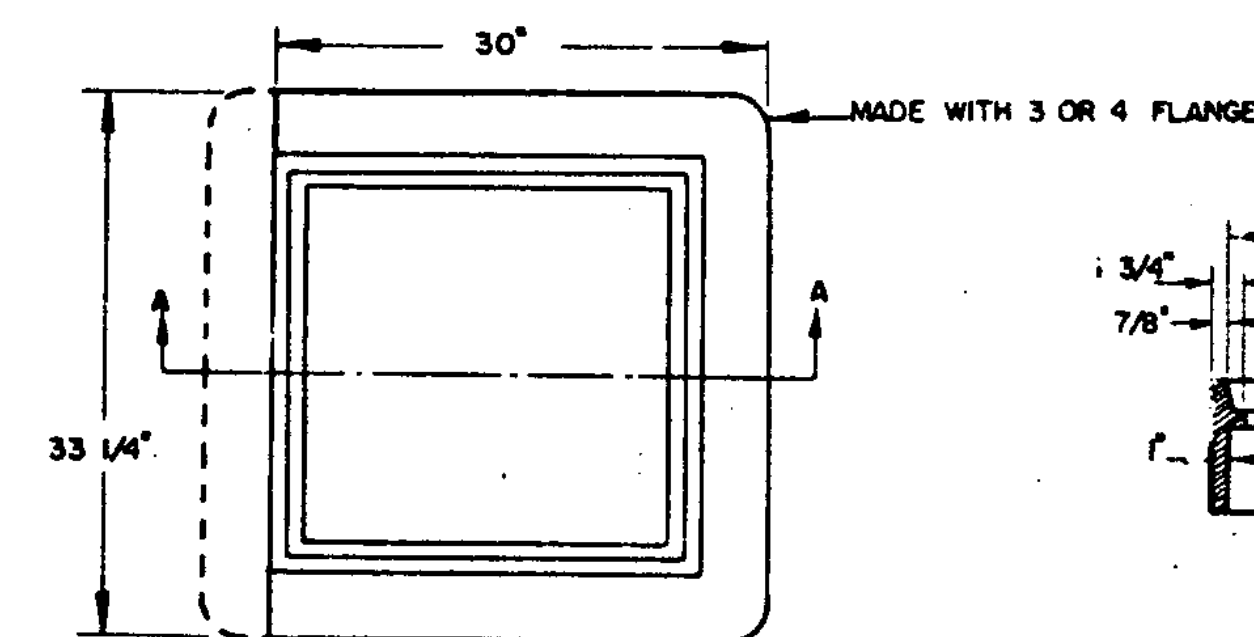

PLAN

SQUARE CAST IRON FRAME FOR CAST IRON GRATE TYPE A

*NOTE: FRAME DEPTH TO BE "6" WHEN USED IN CONJUNCTION WITH DROP INLET DETAILED ON STANDARD D-6.

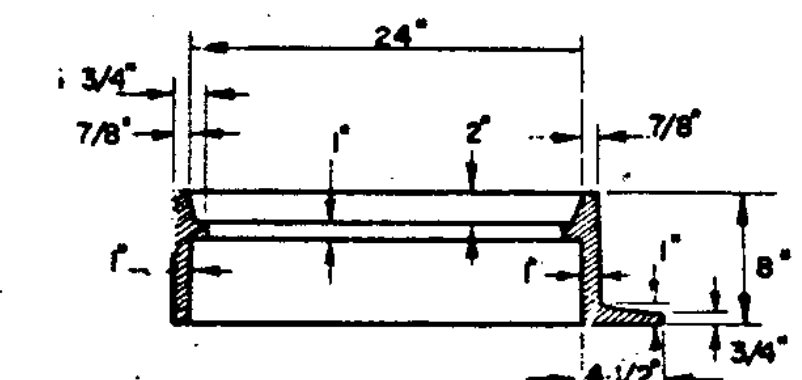

SECTION A-A

THIS FRAME TO BE PLACED IN DROP INLET TOP BEFORE CONCRETE IS POURED.
4 FLANGES UNLESS OTHERWISE INDICATED.
FRAMES TO BE FURNISHED WITH 3 FLANGES WHEN USED IN CONJUNCTION WITH CURB OR AS DIRECTED BY THE ENGINEER.

REVISIONS AND CORRECTIONS

APRIL 25, 1972 CAST IRON COVER CHANGED FROM SQUARE TO CIRCULAR
SEPT. 4, 1980 OPTIONAL CROSSBAR ADDED TO 'A' GRATE;
NOTE ADDED TO 'A' GRATE FRAME DETAIL.
AUG 24, 1981 NOTE ADDED RESTRICTING USE OF TYPE A GRATE.

APPROVED

DATE *Dec 6, 1971*

R.W. Arnold
CHIEF ENGINEER
E.H. Stinchney
ASST. CHIEF ENGINEER
G.M. Lane
HIGHWAY ENGINEER

DRAWN: G. A. J. A.
TRACED: A. J. A.

**STEEL GRATE
CAST IRON GRATE TYPE A
CAST IRON COVER**

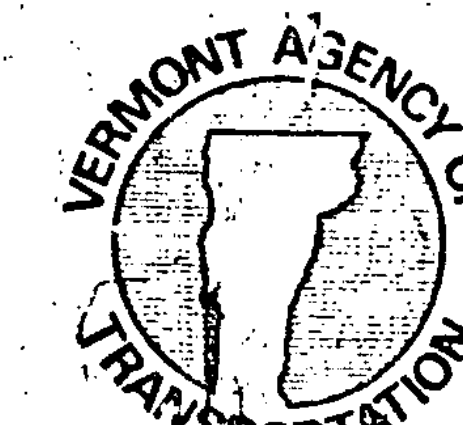

**STANDARD
D-11**