

**ABUTMENT BEARING STIFFENERS  
FOR WELDED PLATE GIRDERS**

NTS

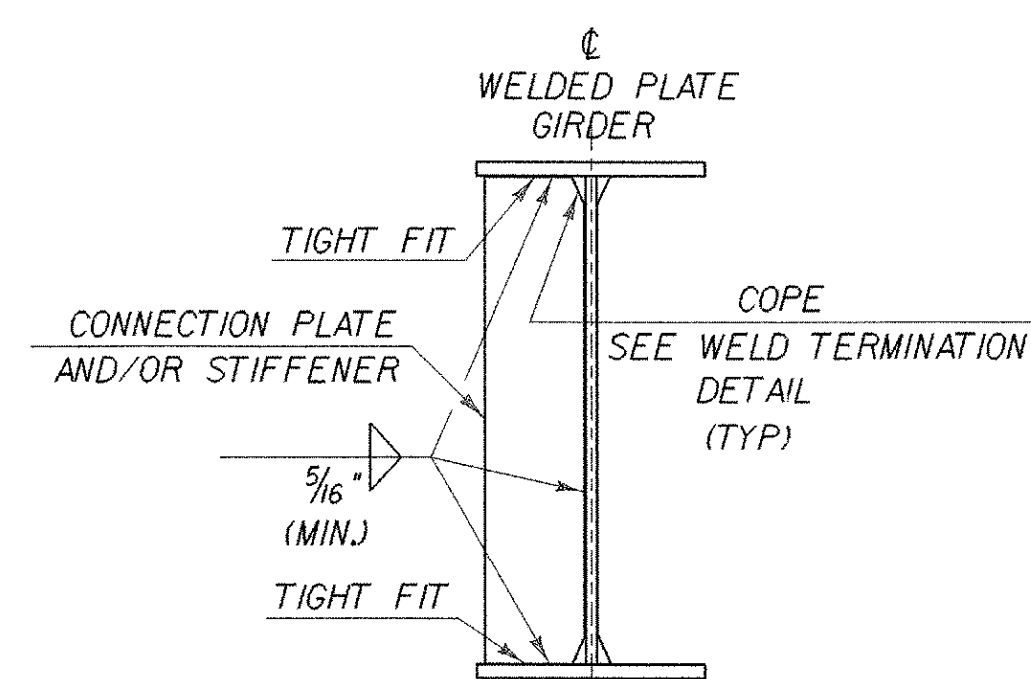

**INTERMEDIATE CONNECTION  
PLATES AND/OR STIFFENERS  
FOR WELDED PLATE GIRDERS**

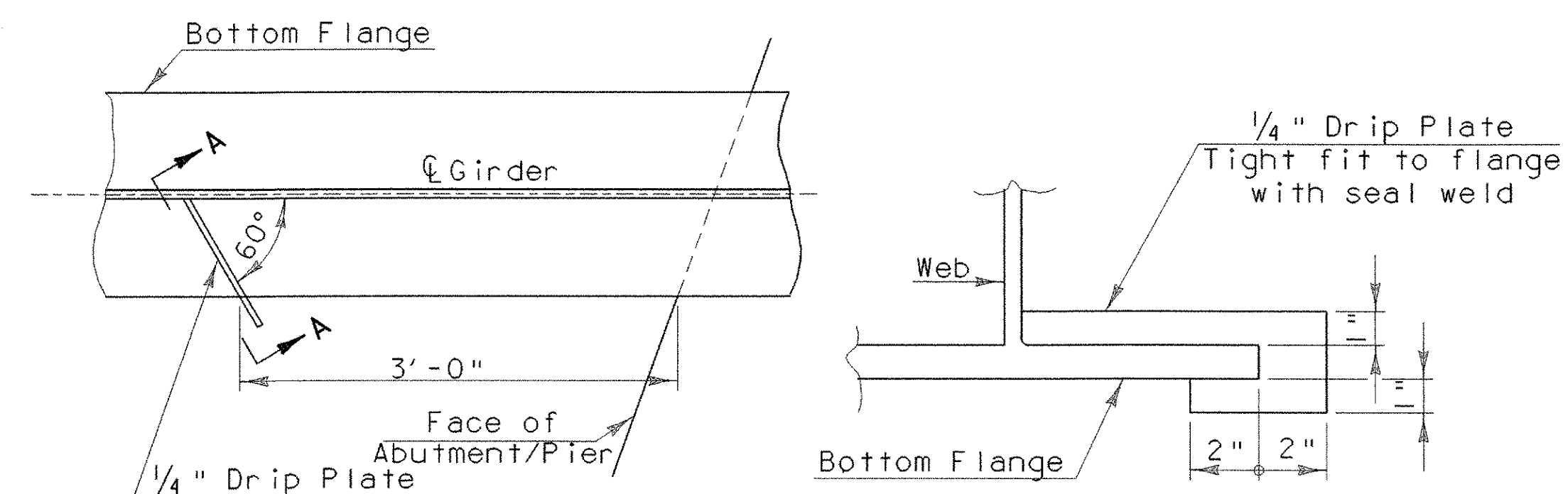

**PLAN DRIP PLATE**

**SECTION A - A**

Note:  
Drip Plates shall be placed on outside edge of fascia girders on the high side of all abutments and the Pier.

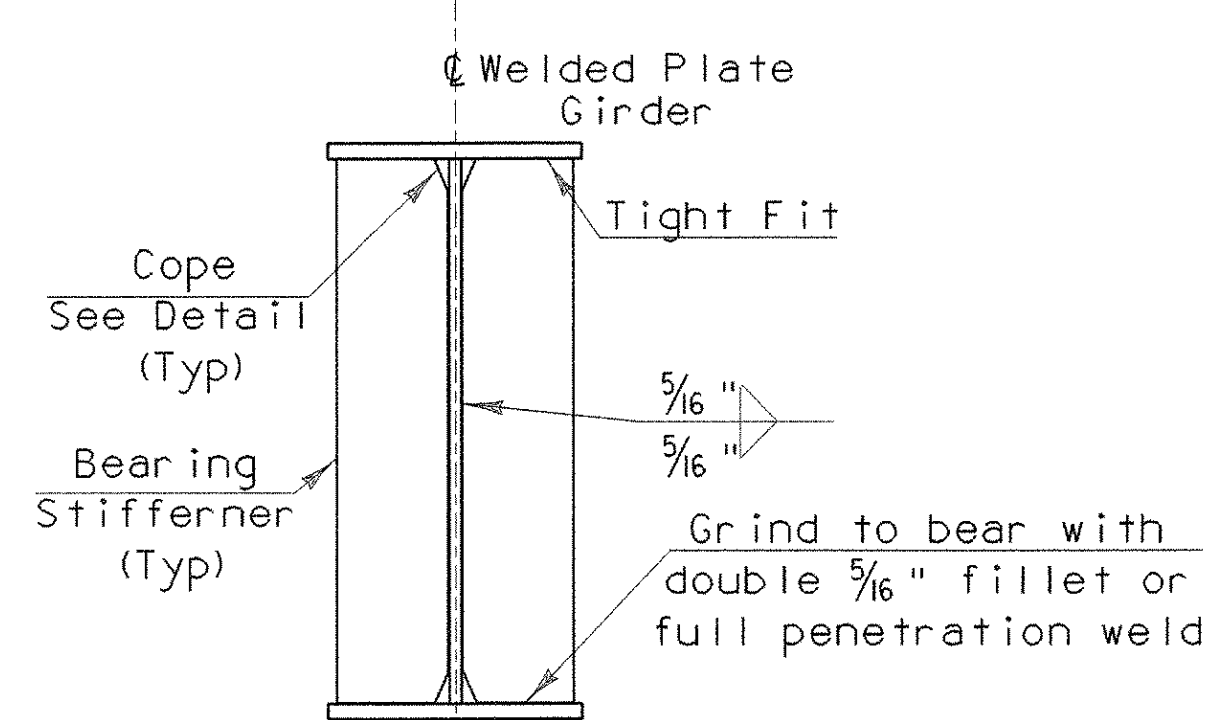

**PIER BEARING STIFFENERS  
FOR WELDED PLATE GIRDERS**

NTS

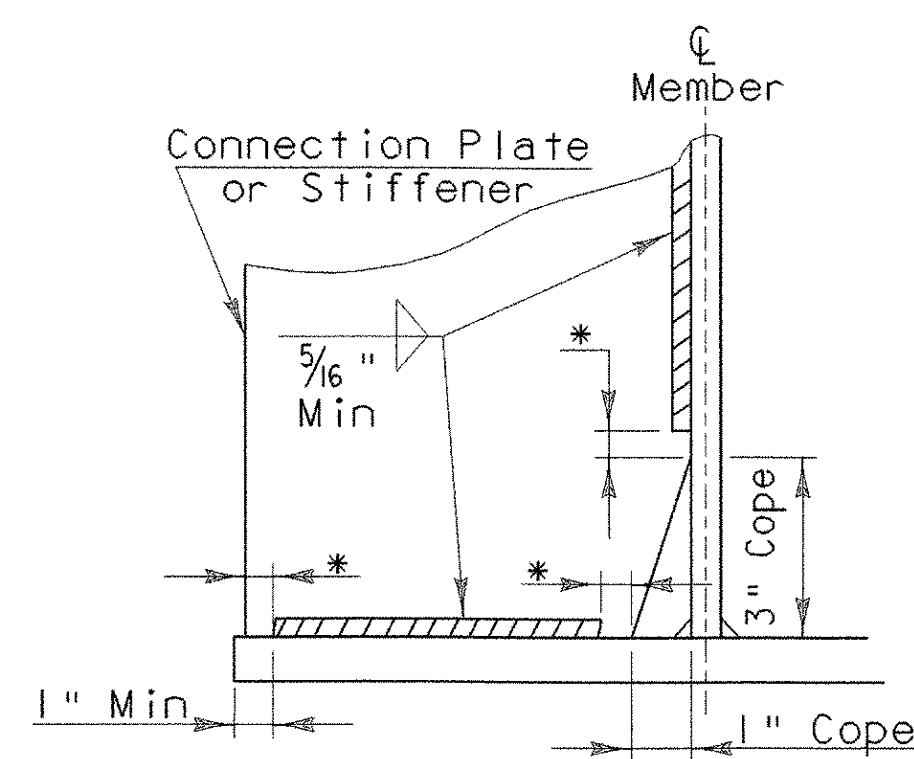

\*No weld for 1/4" Min, 1/2" Max  
(Except must maintain 1" minimum from edge of flange)

**WELD TERMINATION AND COPING  
DETAILS FOR STEEL MEMBERS**

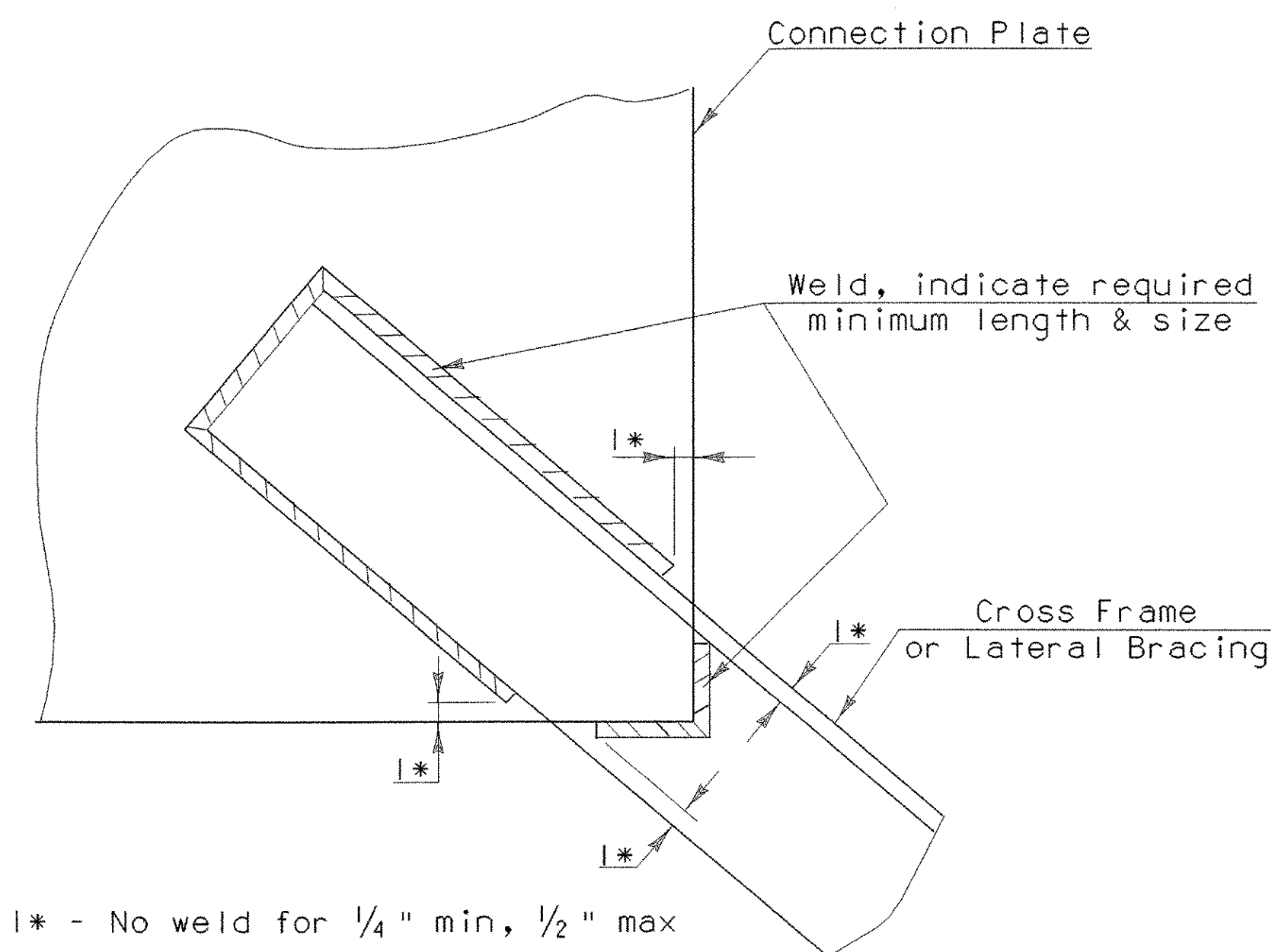

**WELD LOCATION DETAIL  
AT CROSS FRAMES AND  
LATERAL BRACING**

PROJECT NAME: ROYALTON BRZ 1444 (22)  
PROJECT NUMBER:

FILE NAME: 89\099\structures\sj099ssd.dgn PLOT DATE: 25-SEP-2000  
IPARM NAME: sj099ssd1.i DRAWN BY: D.G. BASSETT  
PROJECT LEADER: C.P. WILLIAMS CHECKED BY: W.B. SYMONDS  
DESIGNED BY: W.B. SYMONDS SHEET 38 OF 118  
MISCELLANEOUS STEEL DETAILS