

ADDITIONAL DIMENSIONING MAY BE REQUESTED BY THE RESIDENT ENGINEER

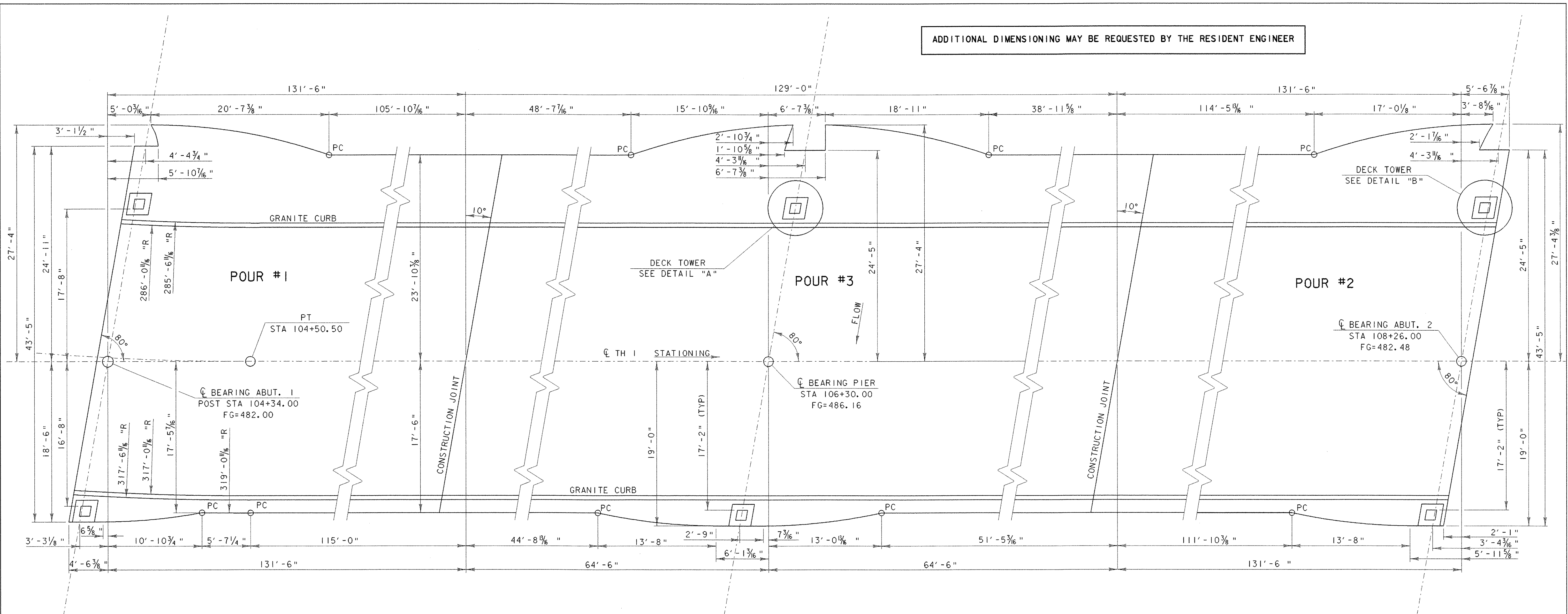

DECK LAYOUT PLAN

SCALE 3/16" = 1'-0"

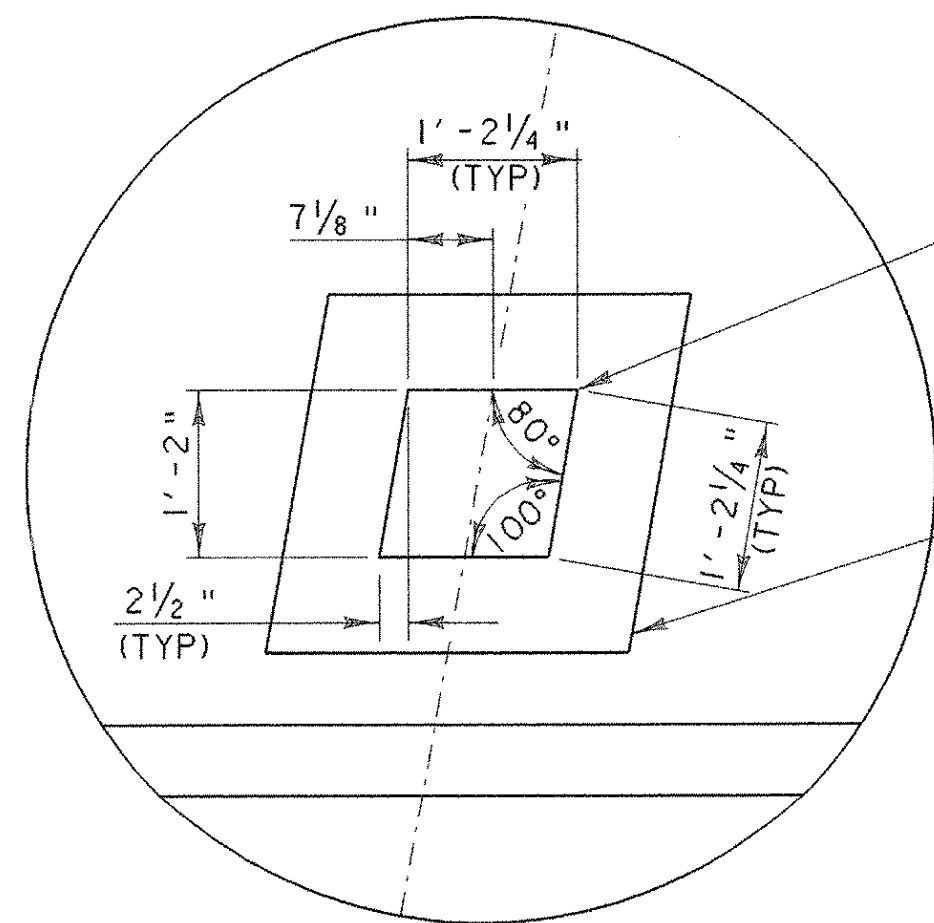

DETAIL "A" PIER

SCALE 3/4" = 1'-0"

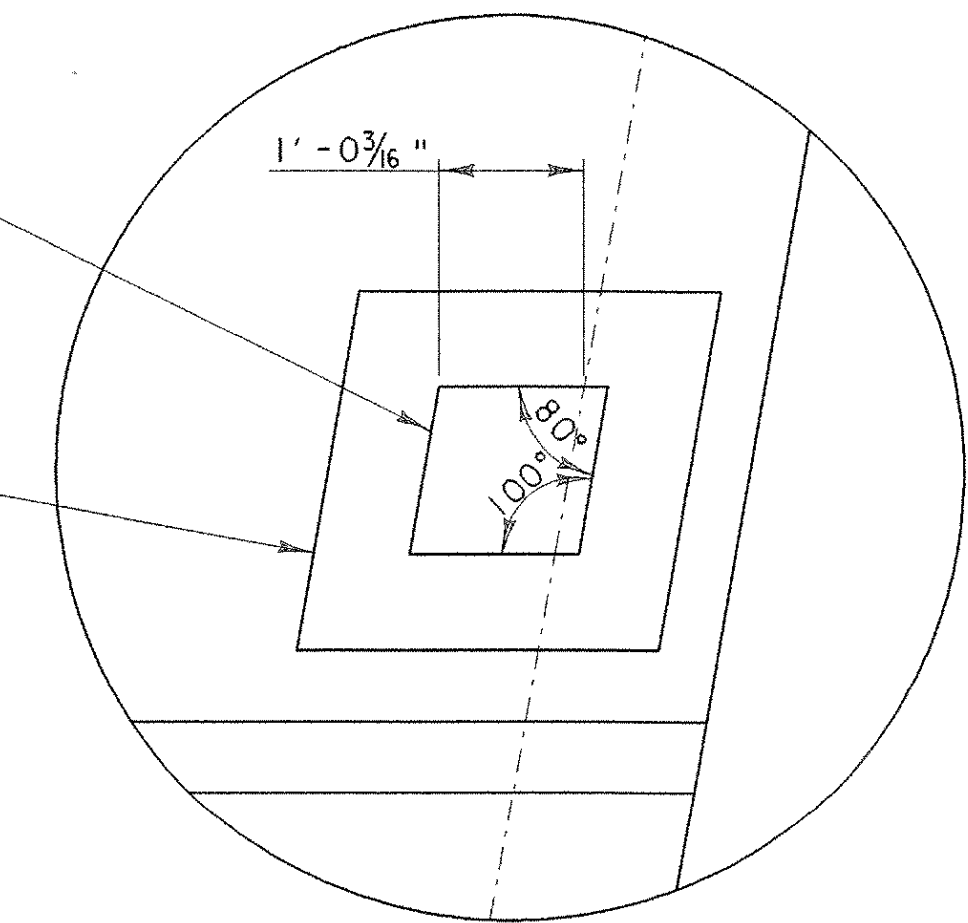

DETAIL "B" ABUT. 1&2

SCALE 3/4" = 1'-0"

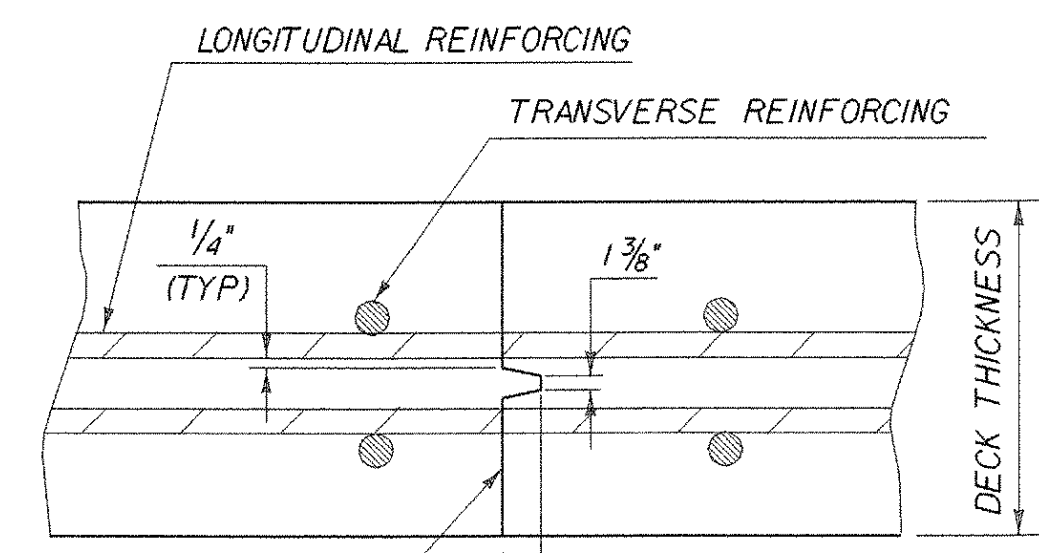

TRANSVERSE BRIDGE SLAB  
 CONSTRUCTION JOINT DETAILS

NOTES:

- IF APPROVED BY THE ENGINEER, POURS #1 & #2 MAY BE POURED THE SAME DAY PROVIDED THAT THE MAXIMUM TIME SPAN OF THE POUR IS EIGHT HOURS. THE INDICATED POURING SEQUENCE SHALL BE FOLLOWED AND A RETARDING ADMIXTURE USED SO THAT THE DECK CONCRETE WILL NOT SET UP UNTIL ALL THE POUR HAS BEEN MADE. THE RETARDING ADMIXTURE SHALL BE SUBSIDIARY TO THE ITEM 501.221 "CONCRETE, CLASS A QC/OA (MOD)".
- TRANSVERSE BRIDGE SLAB CONSTRUCTION JOINTS, AS SHOWN ON THIS SHEET SHALL BE USED BETWEEN ADJACENT DECK POURS.
- ALL INDIVIDUAL DECK POURS SHALL START FROM THE LOW END (RELATIVE TO GRADE).
- THERE SHALL BE A MINIMUM DELAY PERIOD OF 96 HOURS BETWEEN POURS.
- ANY POURING SEQUENCE OTHER THAN INDICATED SHALL BE SUBMITTED, IN WRITING, TO THE PROJECT MANAGER FOR APPROVAL.

PC = POINT OF CURVATURE

PROJECT NAME:	ROYALTON BRZ 1444 (22)	
PROJECT NUMBER:		
FILE NAME:	89j099/structures/sj099sup.dgn	PLOT DATE: 25-SEP-2000
IPARM NAME:	sj099deck layout.i	DRAWN BY: R. S. YOUNG
PROJECT LEADER:	C. P. WILLIAMS	CHECKED BY: W. B. SYMONDS
DESIGNED BY:	W. B. SYMONDS	SHEET 28 OF 118
DECK LAYOUT PLAN		