

NOTE: SEE PROJECT SPECIFIC PLANS & DETAILS FOR BRIDGE GEOMETRY & DETAILS THAT ARE REQUIRED TO CONSTRUCT THE EXPANSION JOINT.

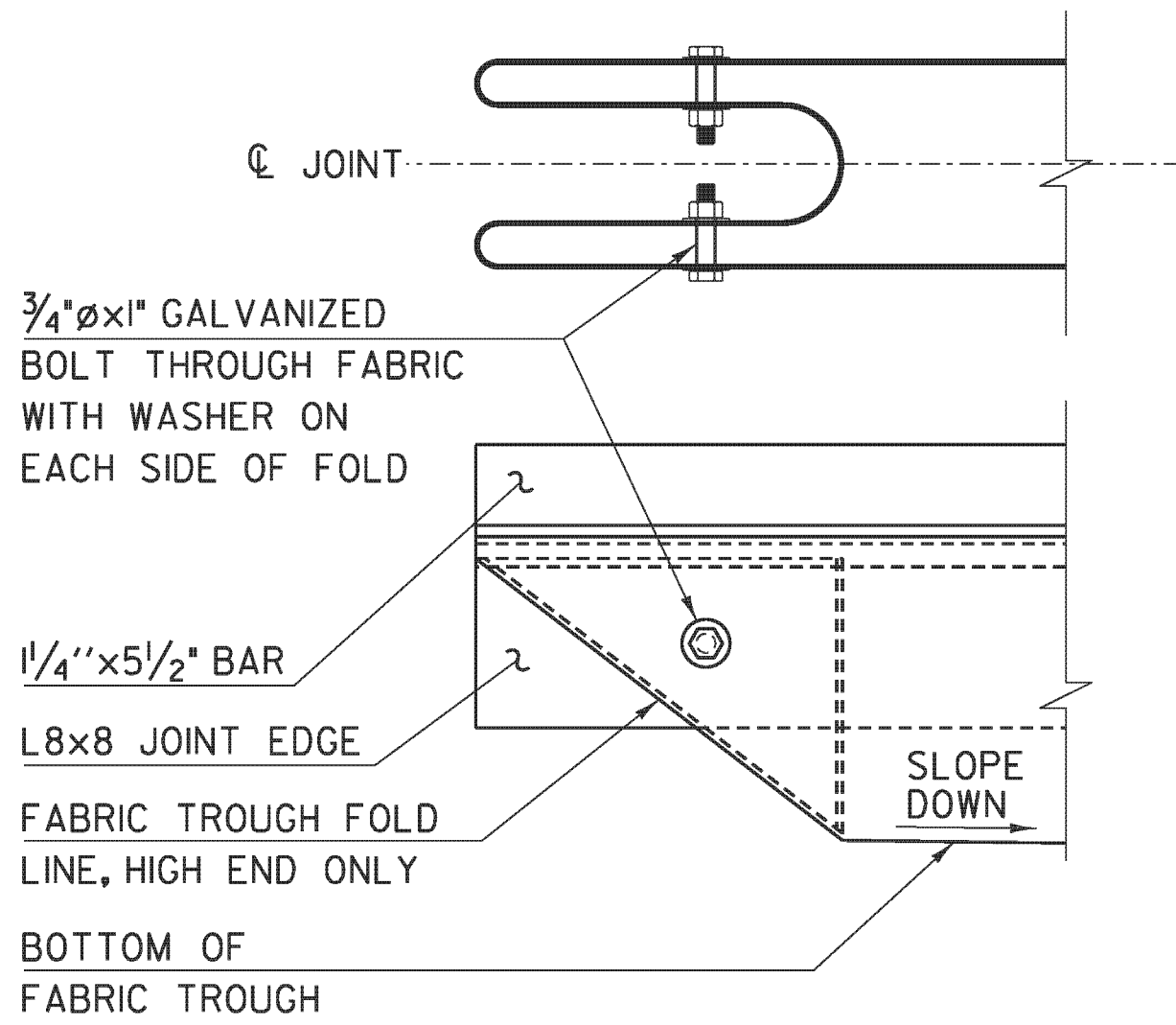
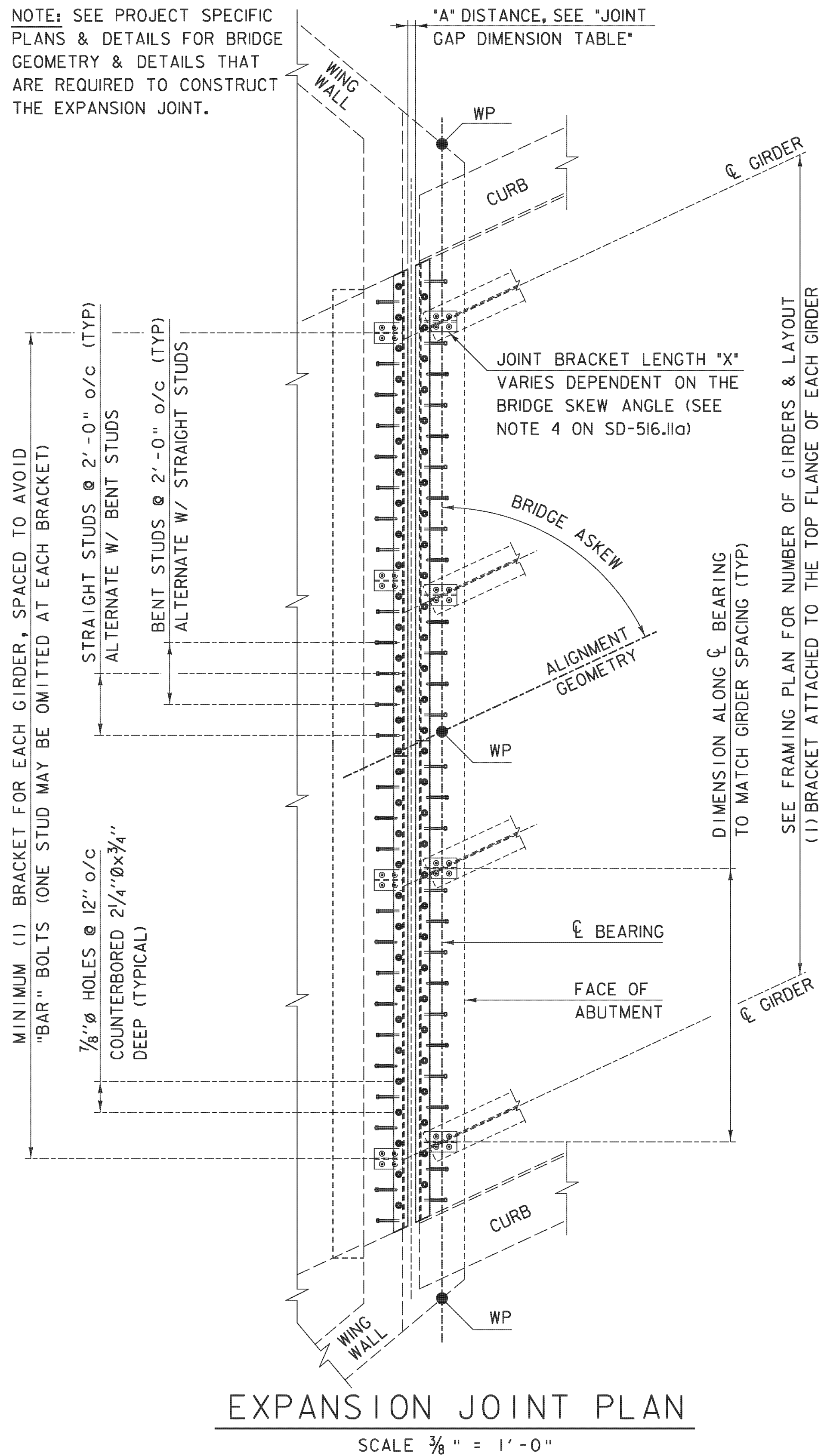

1. TROUGH SHALL BE FOLDED AT HIGH ENDS. TROUGH SHALL SLOPE AT MIN 2% DOWN TOWARD THE NEAREST DRAINAGE SPOUT HOPPER LOCATION.
2. BOLTS, NUTS AND WASHERS FOR FOLD SHALL MEET REQUIREMENTS OF SUBSECTION 714.04 AND SHALL BE GALVANIZED.

JOINT GAP DIMENSION TABLE					
"A" Distance (in)					
Temp (°F)	Expansion Length (ft)				
	100 - 120	>120 - 140	>140 - 160	>160 - 180	>180 - 200
0	1 5/8	1 13/16	1 7/8	1 15/16	2 1/8
15	1 1/2	1 5/8	1 11/16	1 3/4	1 7/8
30	1 5/16	1 1/2	1 1/2	1 1/2	1 5/8
45	1 3/16	1 5/16	1 5/16	1 5/16	1 7/16
60	1 1/16	1 1/8	1 1/8	1 1/16	1 3/16
75	15/16	1	15/16	7/8	15/16
90	3/4	13/16	3/4	11/16	11/16
105	5/8	11/16	9/16	7/16	1/2

- 1) Expansion Length: Length of span, from Expansion Joint to nearest Fixed Bearing.
- 2) "A" Distance: measured distance during joint placement.
- 3) Temp: Approximate temperature of steel during joint placement.

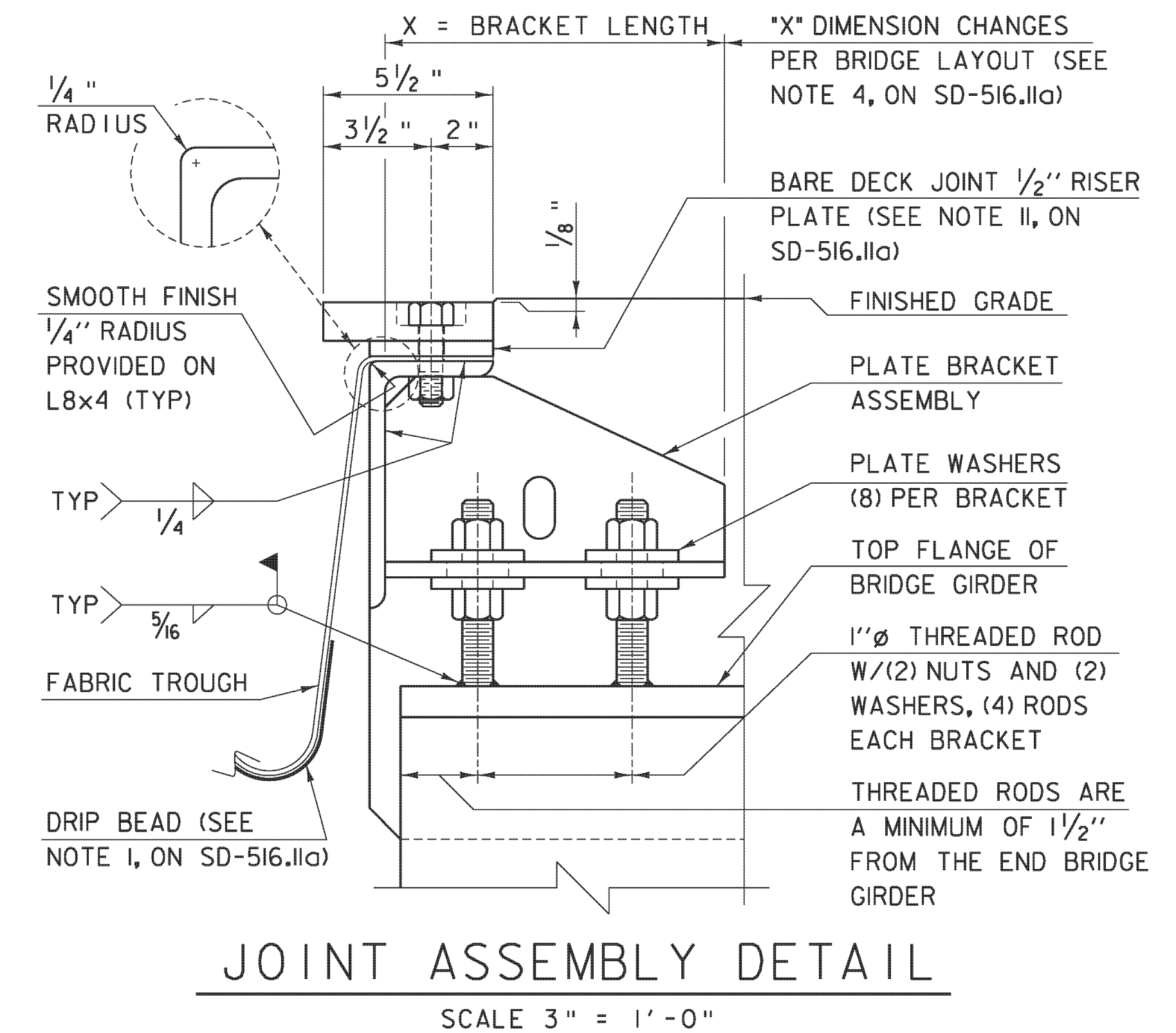
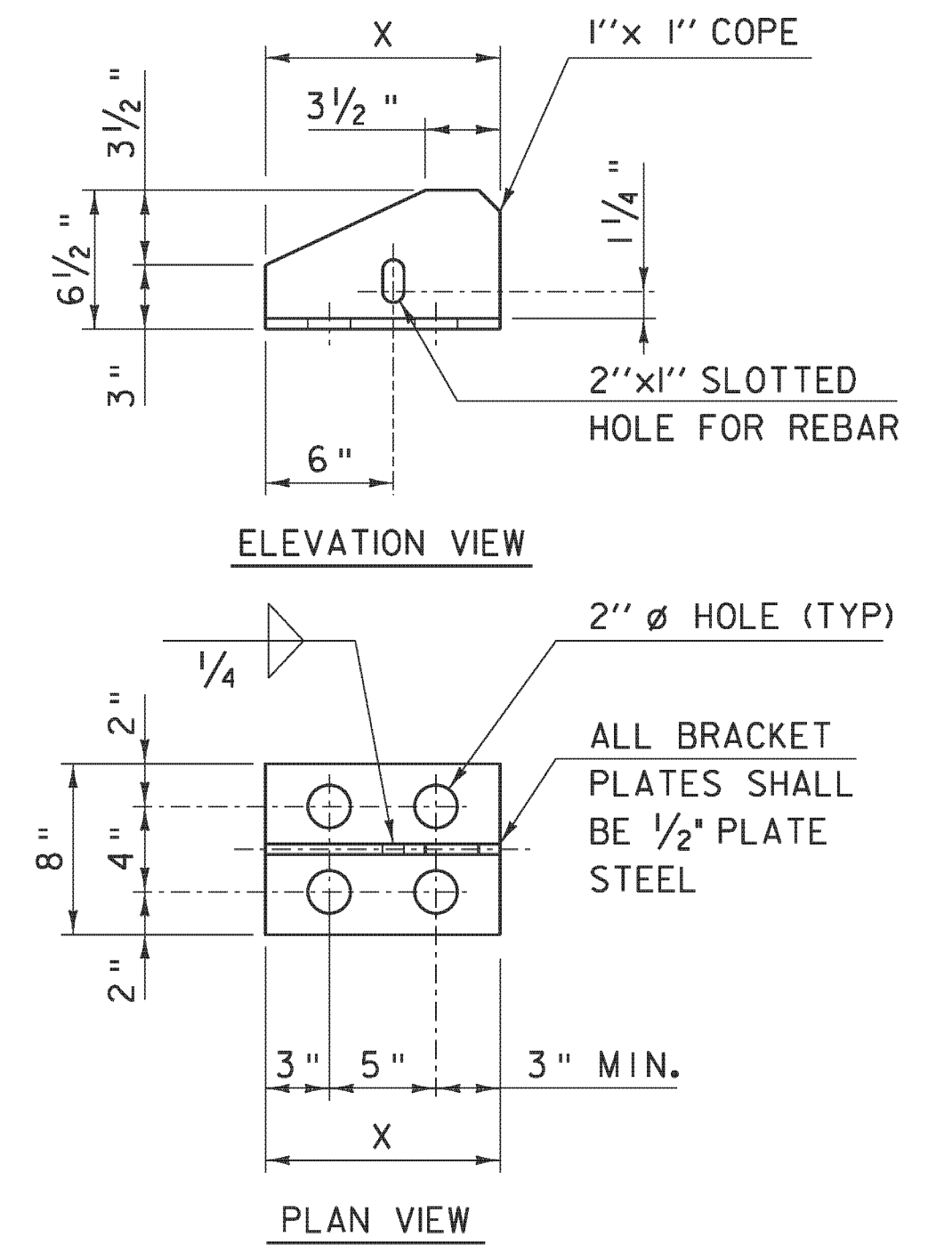
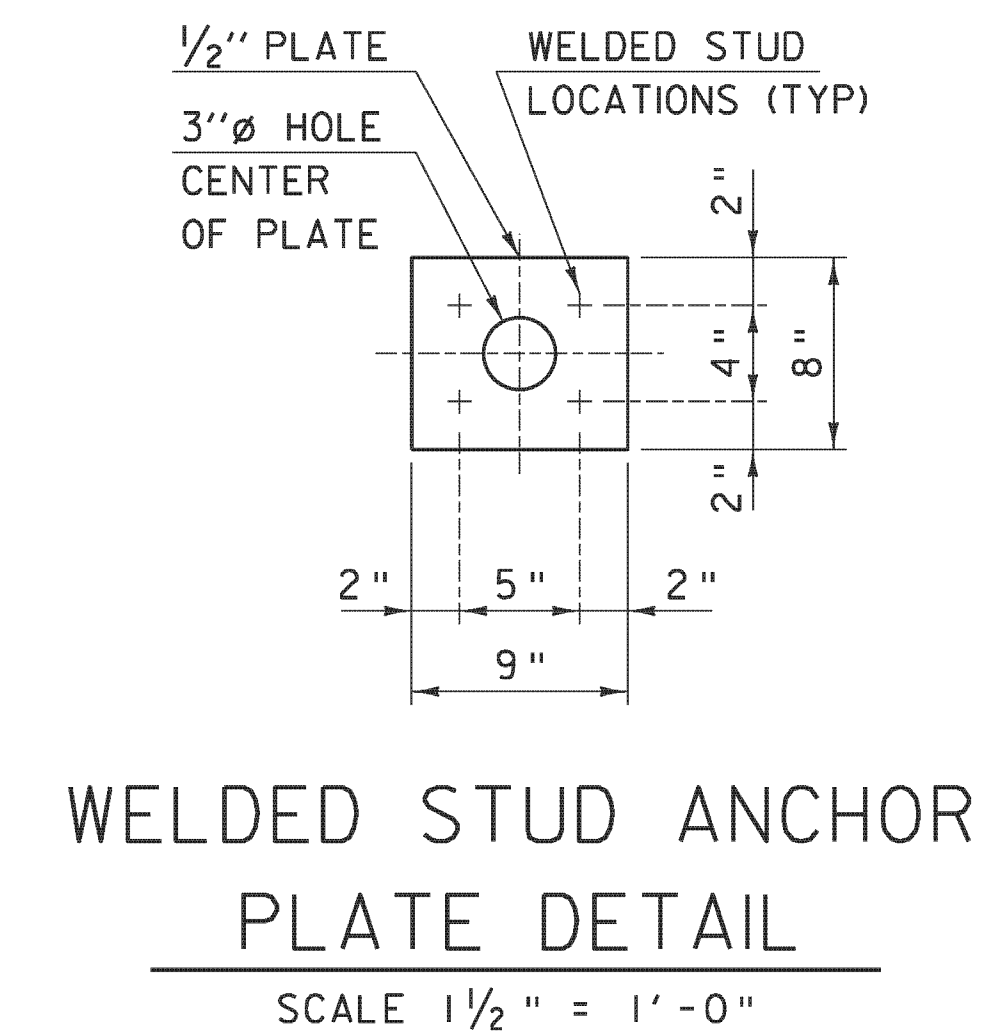
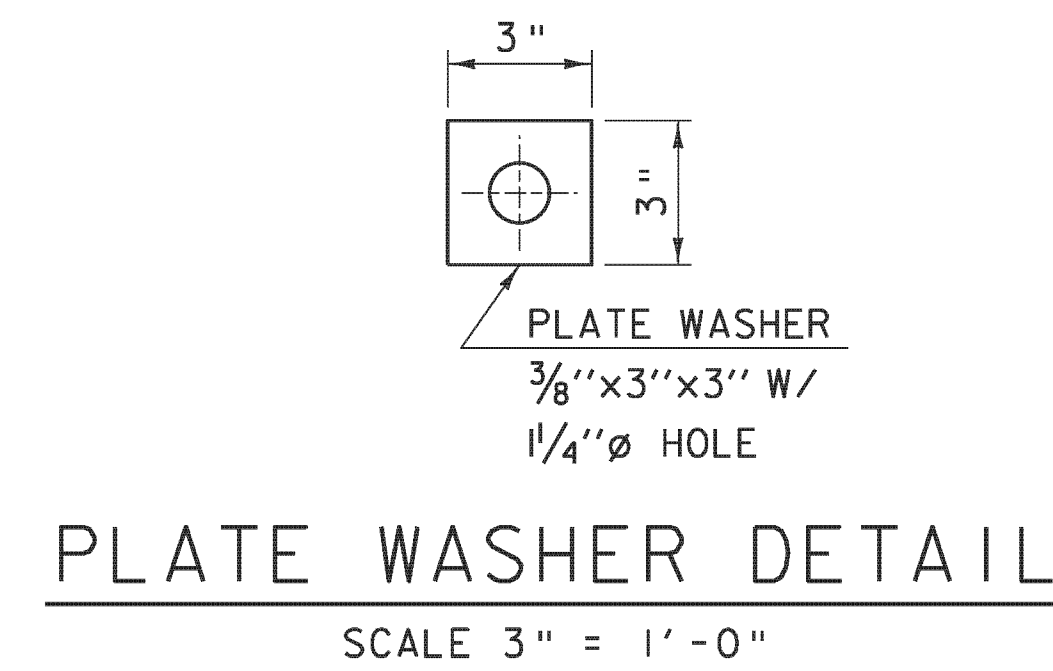

REVISIONS	
FEBRUARY 24, 2011	APPROVED FOR USE BY VAOT STRUCTURES SECTION

BRIDGE EXPANSION JOINT, VERMONT

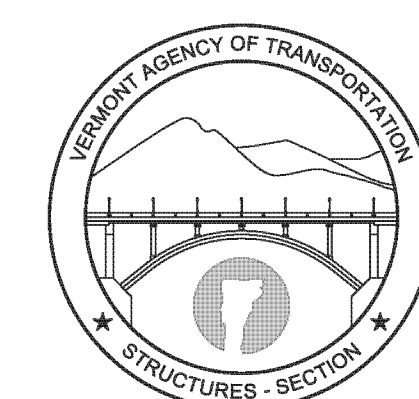

STRUCTURES DETAIL SD-516.11b