

| ABM INFO |      | SHOP BILL |                           |        |     | JOB NO.     | DRG. NO.      |                    |        |
|----------|------|-----------|---------------------------|--------|-----|-------------|---------------|--------------------|--------|
| PAGE     | LINE | NO.       | DESCRIPTION               | FT     | IN  | ASSEM. MARK | SHIPPING MARK | REMARKS            | WEIGHT |
|          |      |           |                           |        |     |             |               |                    |        |
|          |      | 1         | EXP. JOINT                | 15.10E |     | ED1         |               |                    |        |
|          |      |           | L8x4x2                    | 15.93  | a1  |             |               |                    |        |
|          |      | 1         | BAR 5x2                   | 15.93  | b1  |             |               |                    |        |
|          |      | 1         | BAR 7x2                   | 13.93  | b2  |             |               |                    |        |
|          |      | 2         | BAR 1x1                   | 7      | b3  |             |               |                    |        |
|          |      | 3         | R 2x8                     | 10     | be1 |             |               |                    |        |
|          |      | 3         | R 2x6                     | 10     | bf1 |             |               |                    |        |
|          |      | 16        | 3/4" HEX BOLTS            | 3      | ma1 |             |               |                    |        |
|          |      | 16        | 3/4" ANG. FERRULES        | 3      | mb1 |             |               |                    |        |
|          |      | 16        | 3/4" ANG. STUDS           | 10     | mc1 |             |               |                    |        |
|          |      | 16        | 3/4" HEX BOLTS            | 10     | FBI | W/N/W       |               |                    |        |
|          |      | 1         | PREFORMED FABRIC TROUGH   | 16.0E  | mf1 |             |               | 3/4" PER 500000007 |        |
|          |      | 2         | BUTYL RUBBER TAPE 1/2"x3" | 16.0E  |     |             |               | ASHTO 2198-T-2E    |        |
|          |      | 12        | 1/4" THERMO RODS          | 4      |     | TS1         |               |                    |        |
|          |      | 24        | 1/2" HEX NUTS             |        |     | FIELD       |               |                    |        |
|          |      | 24        | R 3x3                     | 3      |     | W1          |               | RE WASH.           |        |
|          |      | 3         | R 2x8                     | 9      |     | API         |               |                    |        |
|          |      | 12        | 3/4" ANG. STUDS           | 10     | mc1 |             |               |                    |        |
|          |      | 3         | 4x4x2                     | 1.2    | sa1 |             |               |                    |        |
|          |      | 3         | 3/4" BOLTS                | 3/2    |     |             |               |                    |        |
|          |      | 3         | RO                        | 3      |     |             |               | W/LE W.            |        |

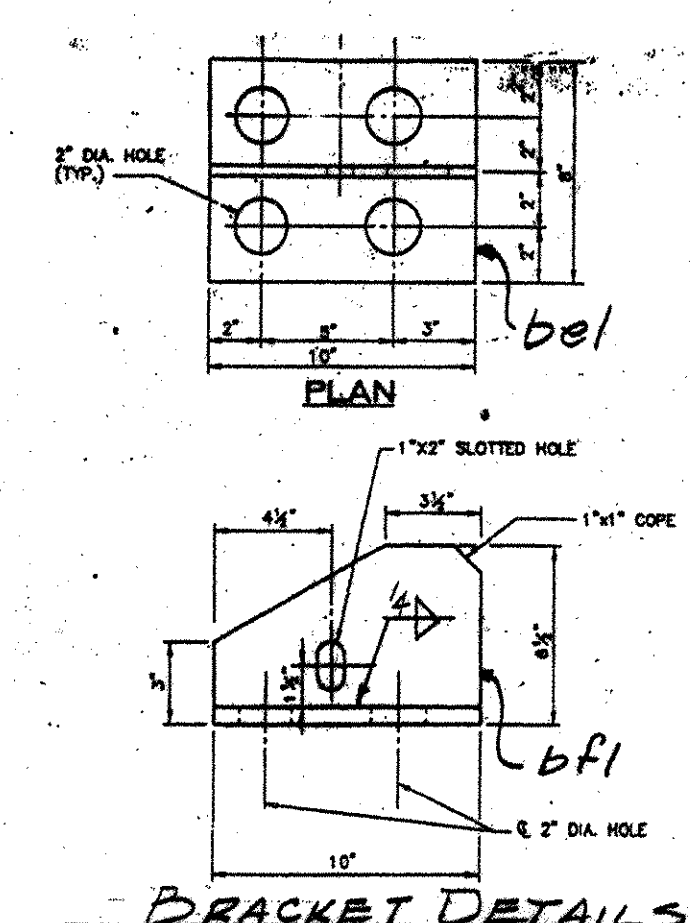

Structures Copy

RECEIVED  
 OK'D BY ALP OK'D BY RSY  
 JUN 11 2007  
 RESUBMIT \_\_\_\_\_ APPROVED AS Mtd  
 BY CPW DATE 7/11/07

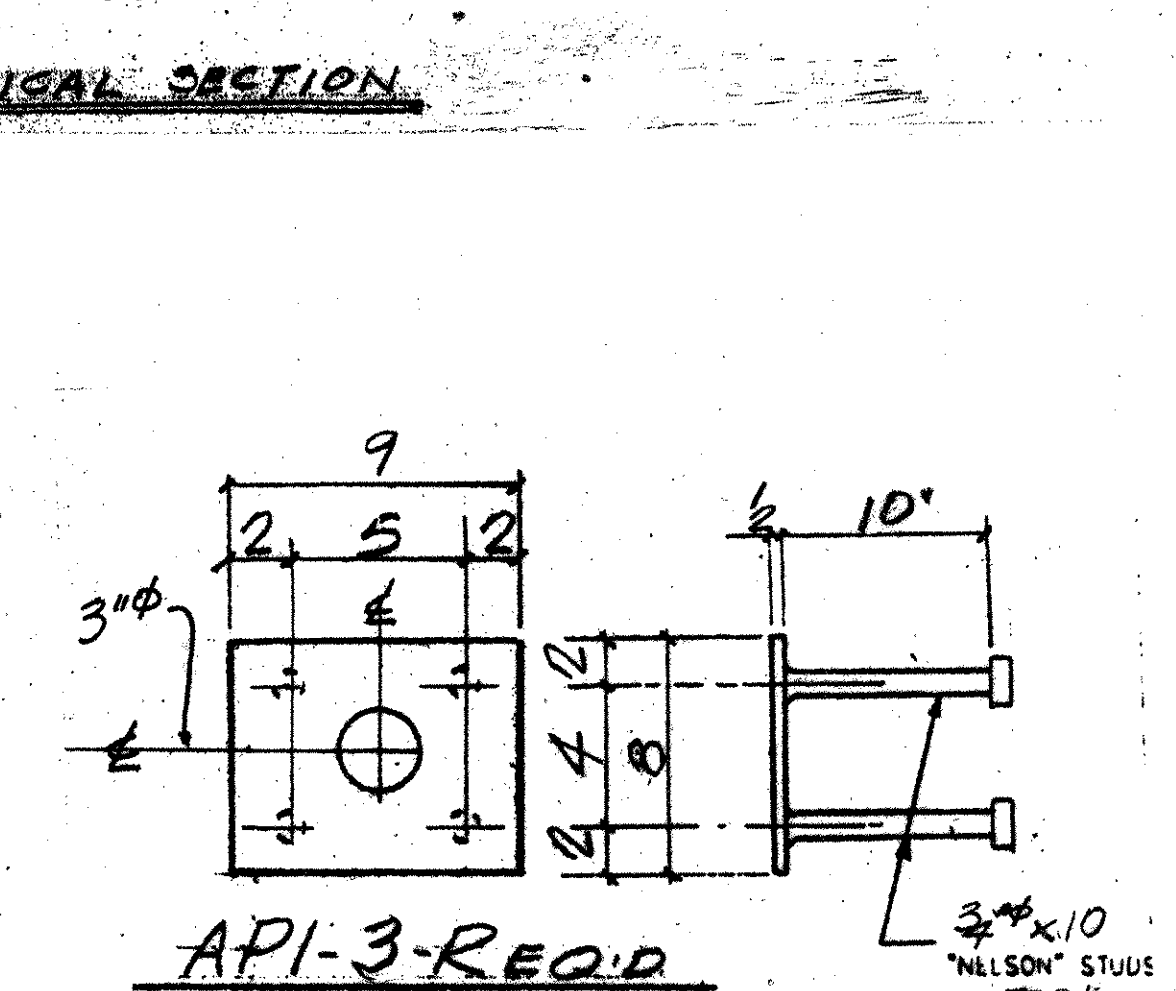
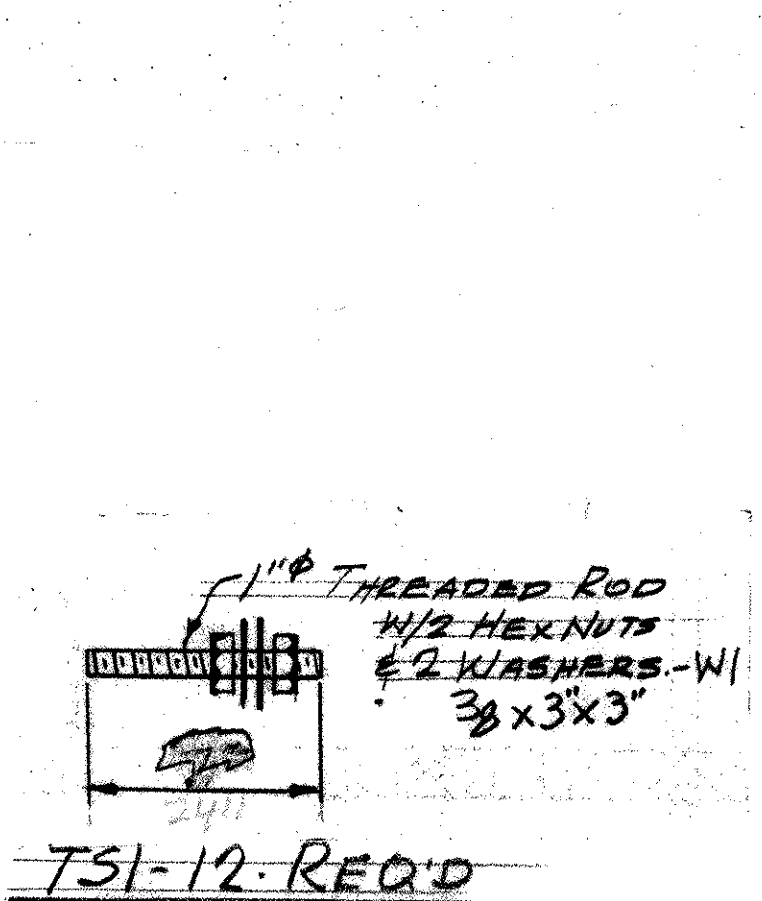
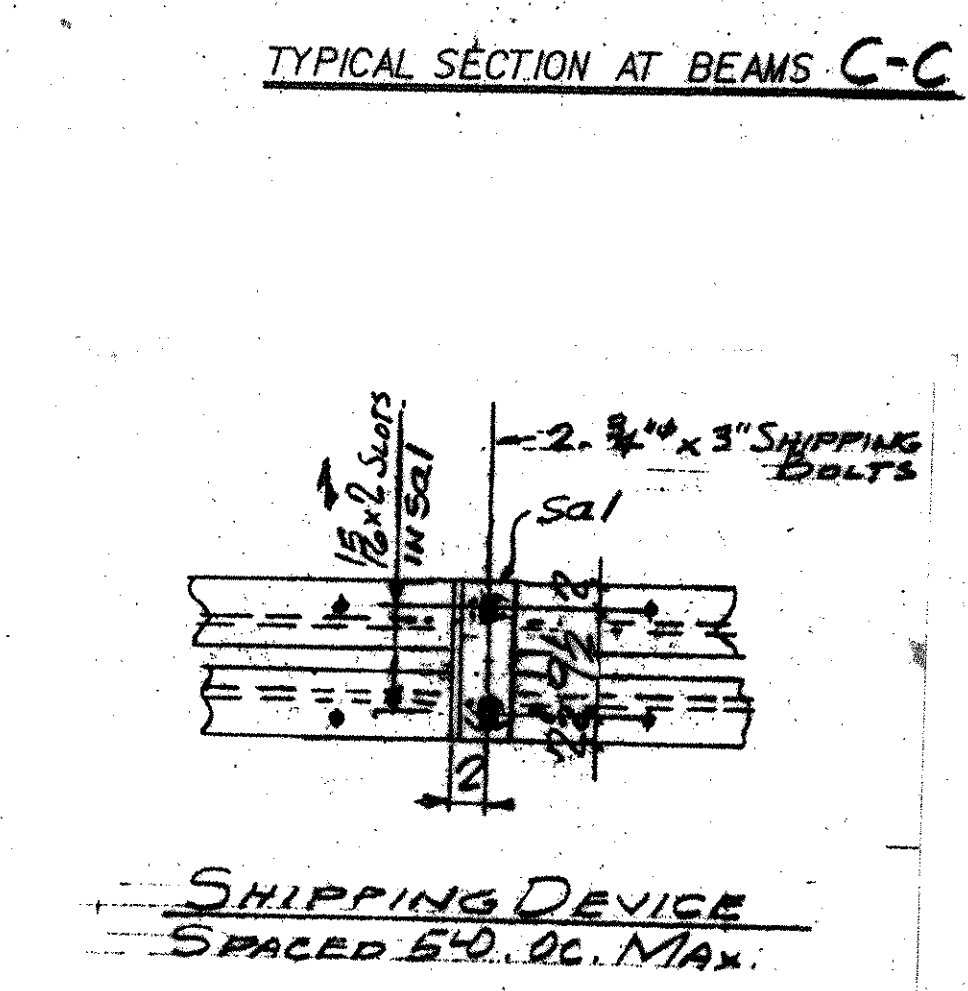
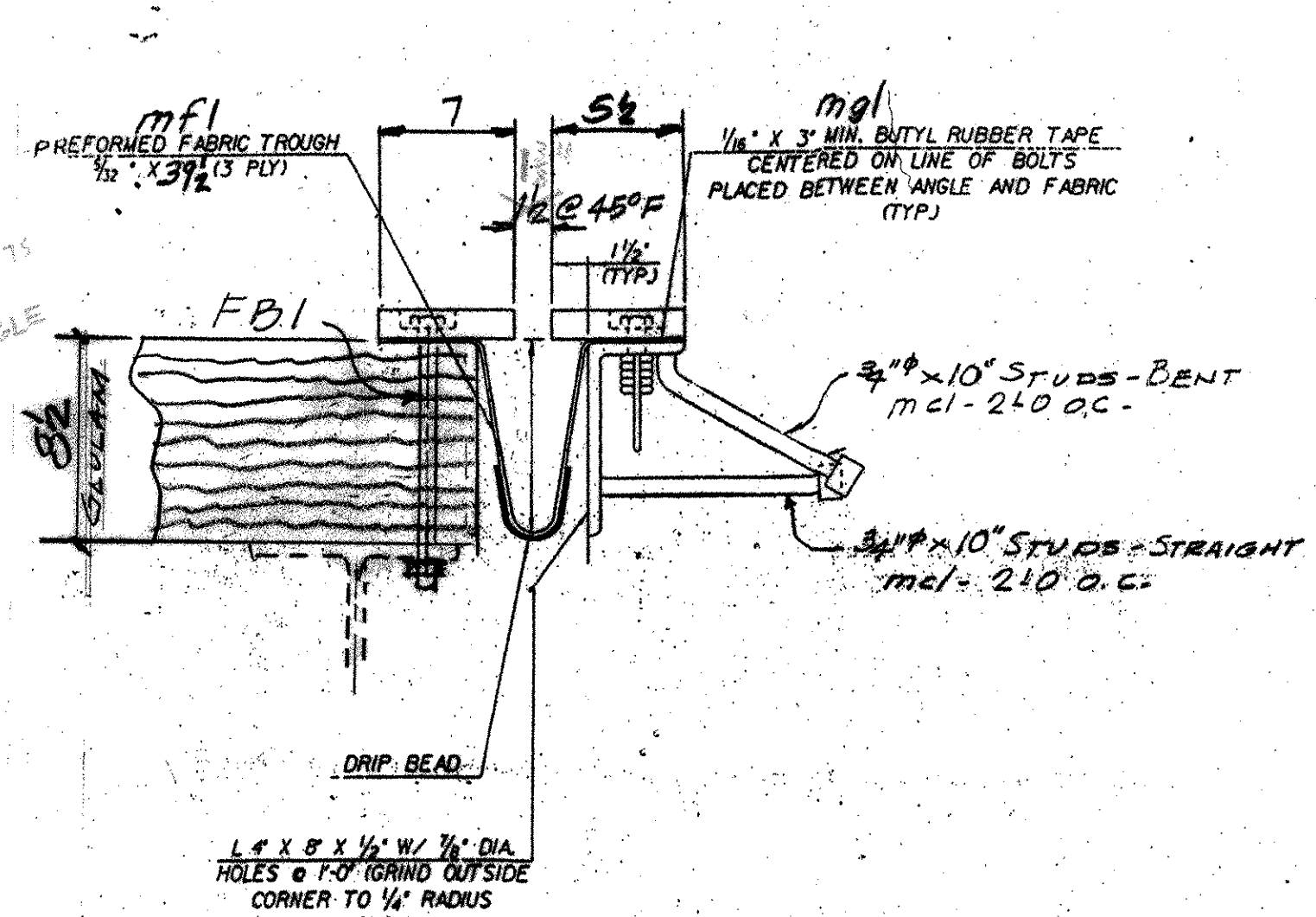
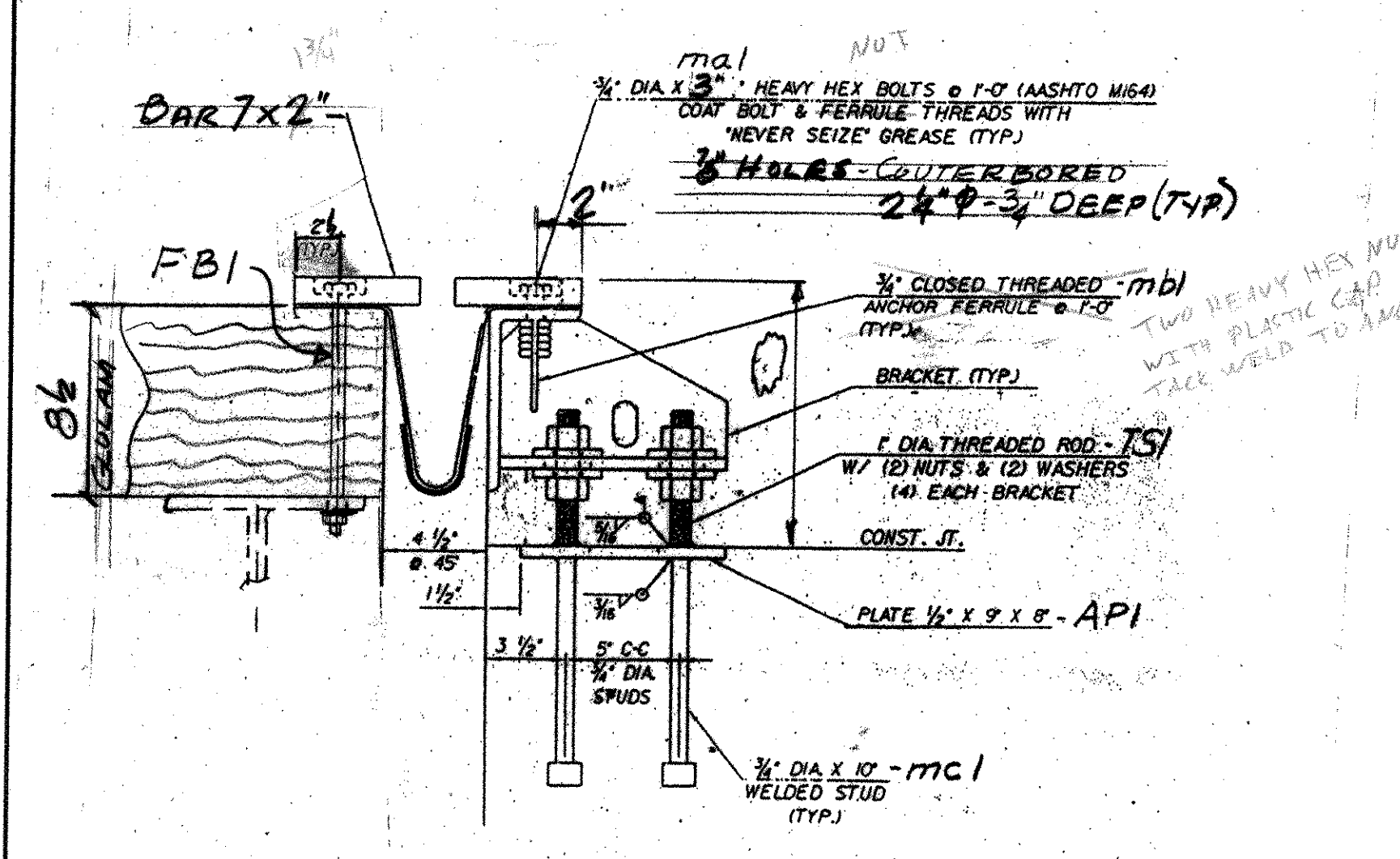
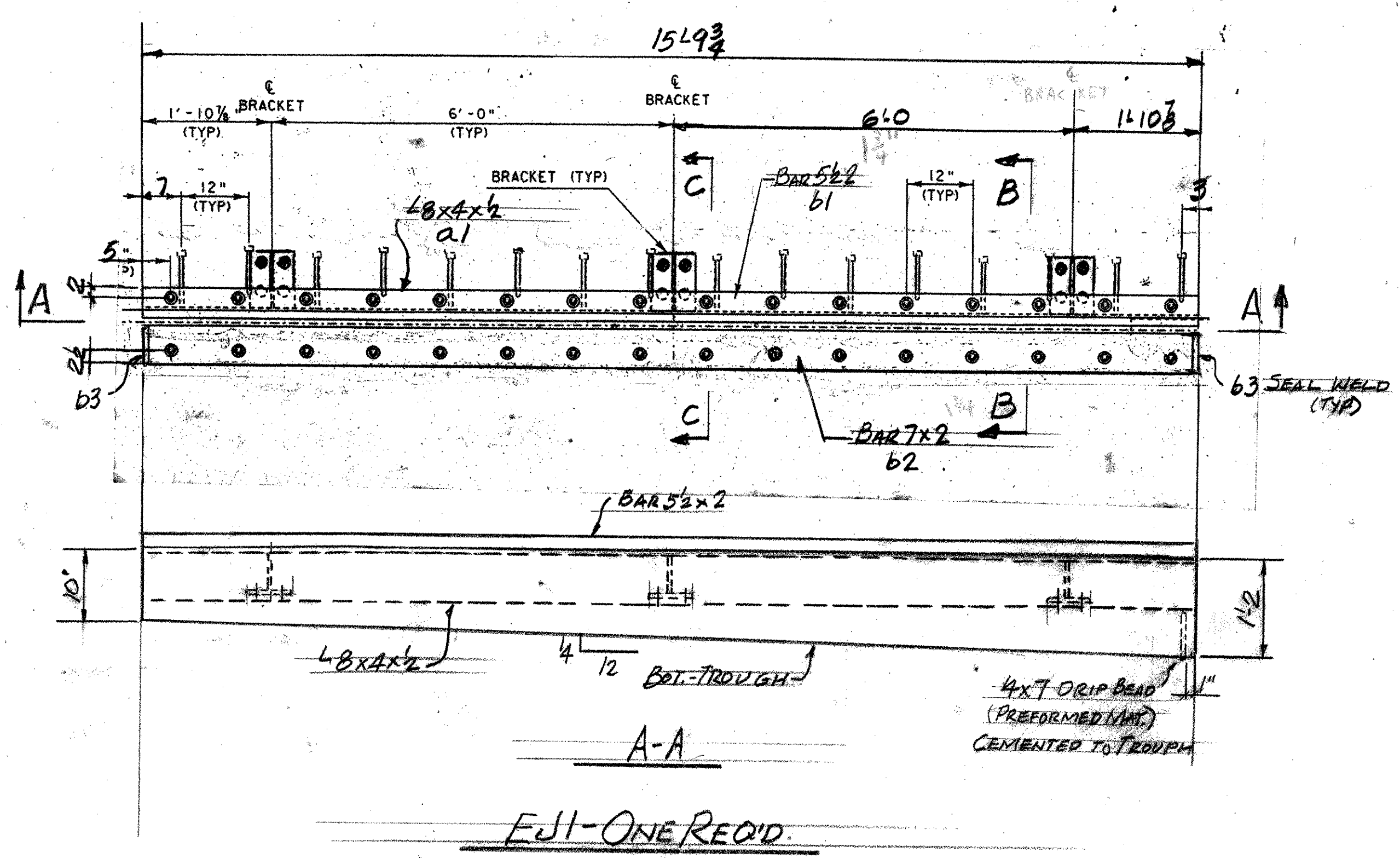
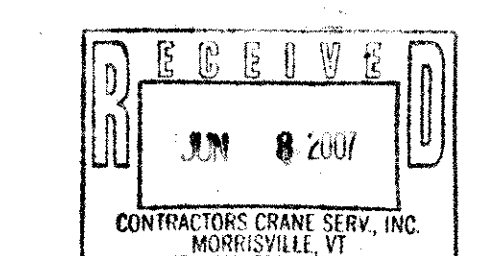

CCS Constructors LLC  
 138 Munson Avenue  
 Morrisville, VT 05661  
 Ph: 802-888-7701 f: 802-888-4746

| REV. | REMARKS   | DATE | DWN | CHK | APP | Q.A. | NO. | DIA. | LGT | TYPE | WASHER |
|------|---|------|-----|-----|-----|------|-----|------|-----|------|--------|
|      | PROJECT NO. BHO-BTN-2006(1) STATE PROJECT NO.   |      |     |     |     |      |     |      |     |      |        |
|      | MATERIAL <u>ASHTO</u> ELECTRODES <u>SEE PROC</u> HOLES <u>AS NOTED</u> SHOP BOLTS <u>3/4"</u> |      |     |     |     |      |     |      |     |      |        |
|      | SURFACE PREP. & PAINT: <u>A325-GALV.</u>  |      |     |     |     |      |     |      |     |      |        |
|      | <u>GALV. AFTER FAB - (ASTM-A123)</u>  |      |     |     |     |      |     |      |     |      |        |
|      | DESCRIPTION: <u>EXPANSION JOINT</u>   |      |     |     |     |      |     |      |     |      |        |
|      | JOB: <u>BRIDGE IMPROVEMENTS</u>   |      |     |     |     |      |     |      |     |      |        |
|      | <u>NEW HAVEN &amp; WEYBRIDGE, VT.</u>   |      |     |     |     |      |     |      |     |      |        |
|      | CUSTOMER: <u>CCS</u>  |      |     |     |     |      |     |      |     |      |        |
|      | <b>CASCO BAY STEEL STRUCTURES, INC.</b>   |      |     |     |     |      |     |      |     |      |        |
|      | 75 SPRING HILL ROAD SACO, MAINE 04072   |      |     |     |     |      |     |      |     |      |        |
|      | PHONE (207) 282-7360 FAX. (207) 282-1179  |      |     |     |     |      |     |      |     |      |        |
|      | JOB NO. <u>329</u> DRG. NO. <u>J1</u>   |      |     |     |     |      |     |      |     |      |        |
|      | REV. <u>Δ</u>   |      |     |     |     |      |     |      |     |      |        |