

ONE REQ'D - RB HANDRAIL 'TR3'
(BACK ELEVATION VIEW)

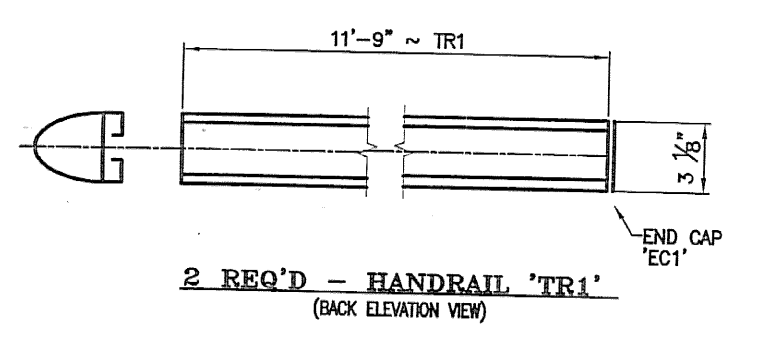

2 REQ'D - HANDRAIL 'TR1'
(BACK ELEVATION VIEW)

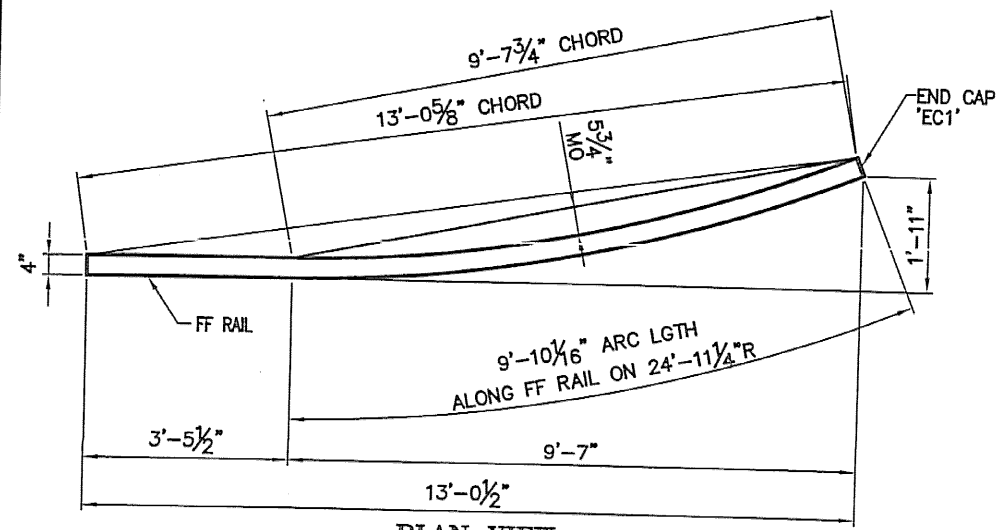

ONE REQ'D - BENT HANDRAIL 'TR2'
(13'-3 9/16" LENGTH ALONG FF RAILING)

ANODIZED
(SEE NOTES ON L&I OF L&S)

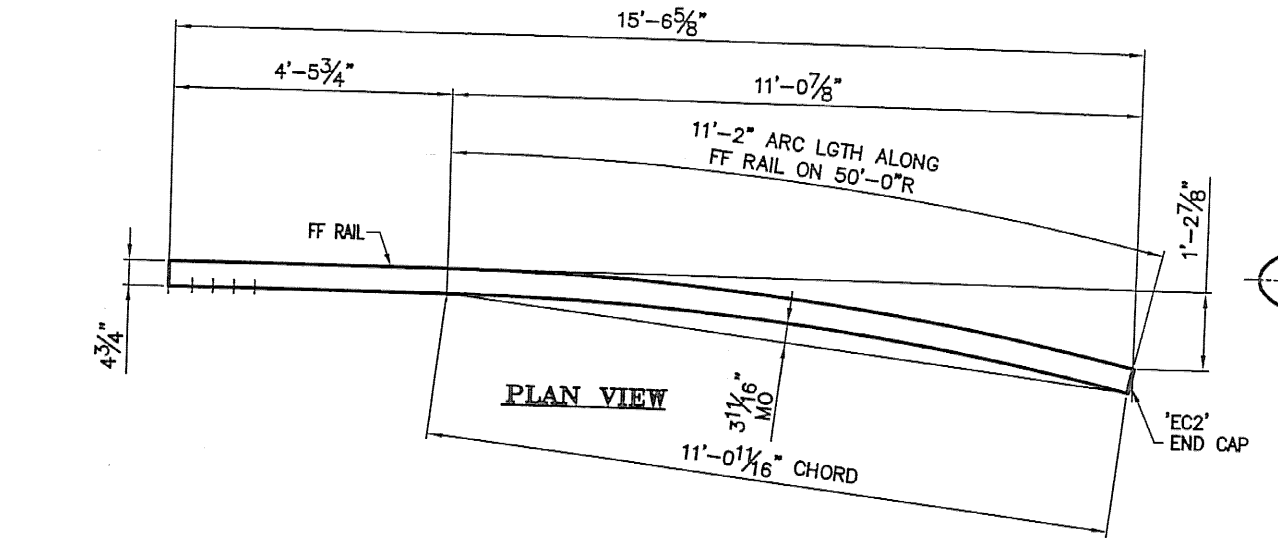

PLAN VIEW

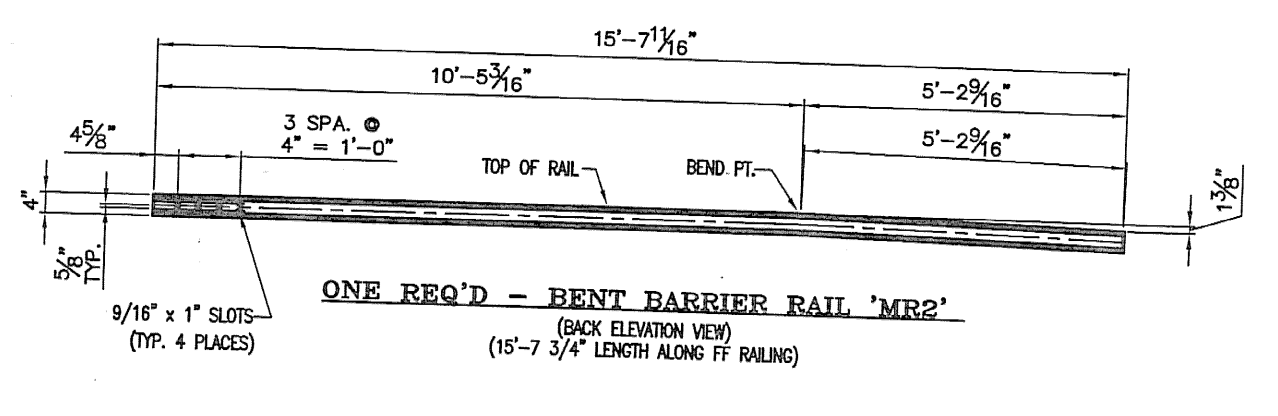

ONE REQ'D - BENT BARRIER RAIL 'MR2'
(15'-7 1/8" LENGTH ALONG FF RAILING)

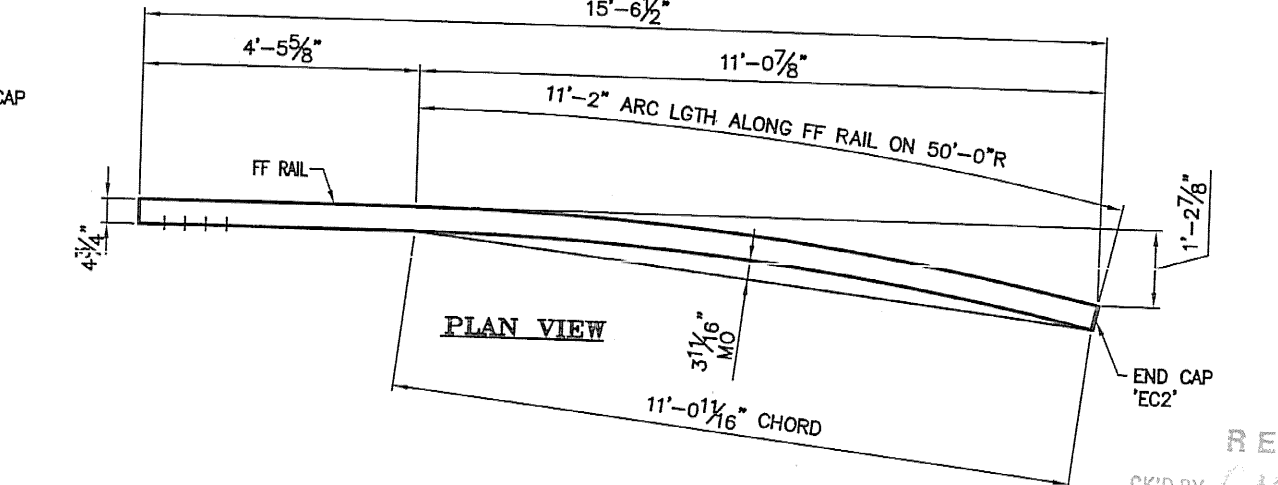

PLAN VIEW

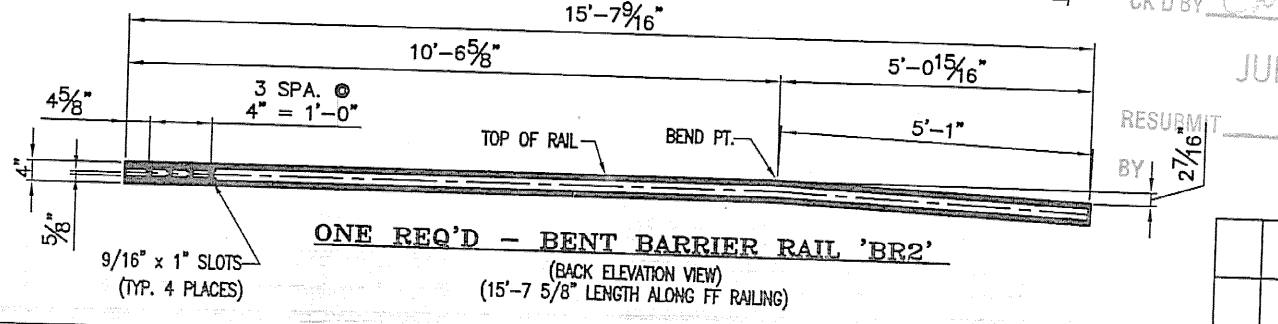

ONE REQ'D - BENT BARRIER RAIL 'BR2'
(15'-7 5/8" LENGTH ALONG FF RAILING)

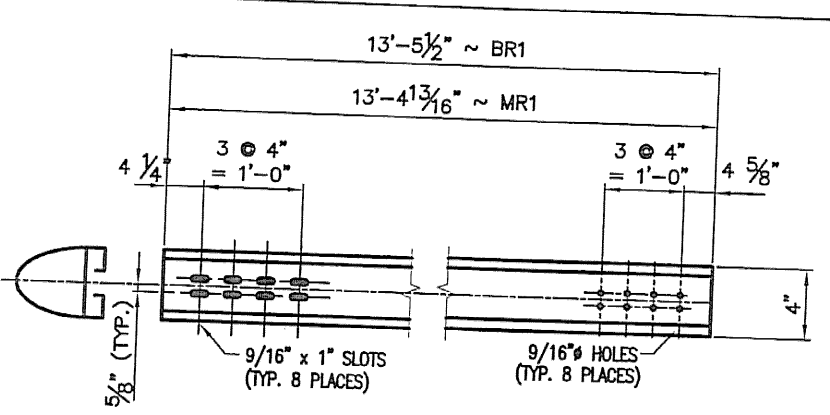

ONE REQ'D - BARRIER RAIL 'MR1'
(BACK ELEVATION VIEW)
ONE REQ'D - BARRIER RAIL 'BR1'
(BACK ELEVATION VIEW)

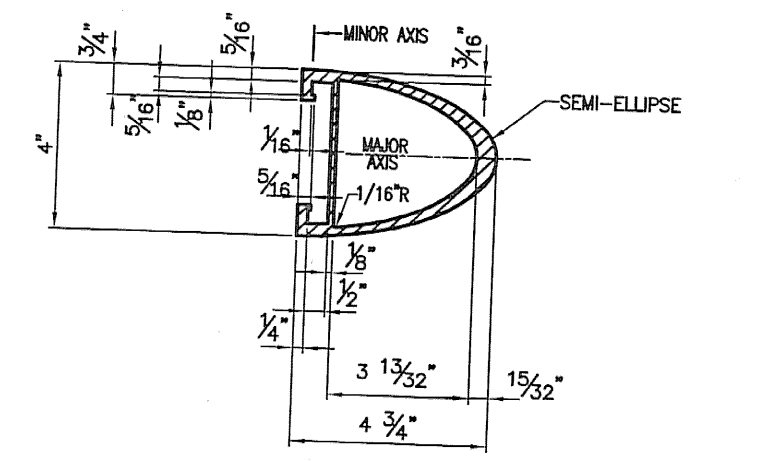

TYPICAL SECTION
(BARRIER RAIL)

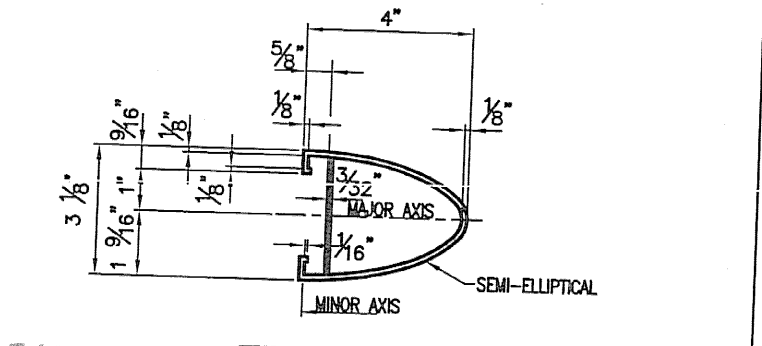

TYPICAL SECTION
(BARRIER RAIL)

RECEIVED
C&D BY [Signature] OK'D BY [Signature]
JUL 09 2008

PROJECT No. BR2 1441(19) G/2 ITEM No. 000.640

APPROVED: [Signature] DATE []

RESUBMITTED BY [Signature] DATE []

FOR: A. D. ROSSI CORPORATION
VERMONT AGENCY OF TRANSPORTATION
TOWN OF FERRIS, COUNTY OF BENNINGTON
BRIDGE RAILING FOR BRIDGE #41, TH 24, CL3 (LOCAL)
31 ALUMINUM APPROACH RAIL - RAIL DETAILS

DATE L&S DATE 08/12/08 JOB No. BR0495 DIST. No. []
CHECK FILE WITH 02/10/08 DRAWING 12112 REV. No. []

REV.	DESCRIPTION	BY	DATE