



Production Joint Welding Procedure Specification (D1.5-02)

Procedure No: B-FSB-01 Date Issued: 3-28-08 Revision No: 0 Rev. Date: _____

Contractor (Fabricator) D. S. Brown Company Prepared by: Brad Streeter, Quality Assurance Manager

- Non-Fracture Critical Fracture Critical WPS Expiration Date: _____
- Qualified in accordance with: AWS D1.5-2002 (5.12.1)
Referenced PQR No(s): PQR-FCAW-01-08
Referenced FWST No(s): N/A
- Material specification(s) ASTM A709 Gr. 36, 50, 50W For DOT Approval
- Material Thickness (es) Unlimited
- Welding process FCAW
- Manual , machine , or semiautomatic
- Position(s) of welding 3G
- Filler metal specification AWS A5.20
- Filler metal class and brand name E71T-1CH8 (UltraCore71C)
- Flux class & brand N/A, Type N/A
- Shielding gas 100% CO2 Flow rate 45 CFH
- Single pass Or multiple pass
- Single arc Or multiple arc
- Welding Current DCEP
- Polarity Reverse
- Welding progression Stringers
- Root treatment Clean to bright sound metal or per AWS D1.5 (3.2.1 & 3.11)
- Postheat treatment N/A
- Calculated Heat Input (KJ/in) Min 31.20 KJ/in Max 50.72 KJ/in
- Electrode extension (electrical stickout) 3/4"

For DOT Approval
 RECEIVED
 JUN 03 2008
 APPROVED: [Signature]
 DATE: 6/9/08

Weld Size (E)(K)(S)	Pass No(s)	Electrode Size (in)	Welding Process Variables		Travel Speed (IPM)	Travel (in)
			AMPS/WFS*	VOLTS		
1/4"	1	1/16"	260-310	26-30	11-13	
5/16"	1	1/16"	260-310	26-30	11-13	
3/8"	2-3	1/16"	260-310	26-30	11-13	
1/2"	3-4	1/16"	260-310	26-30	11-13	
5/8"	4-6	1/16"	260-310	26-30	11-13	
3/4"	5-7	1/16"	260-310	26-30	11-13	
7/8"	6-8	1/16"	260-310	26-30	11-13	
1"	7-9	1/16"	260-310	26-30	11-13	

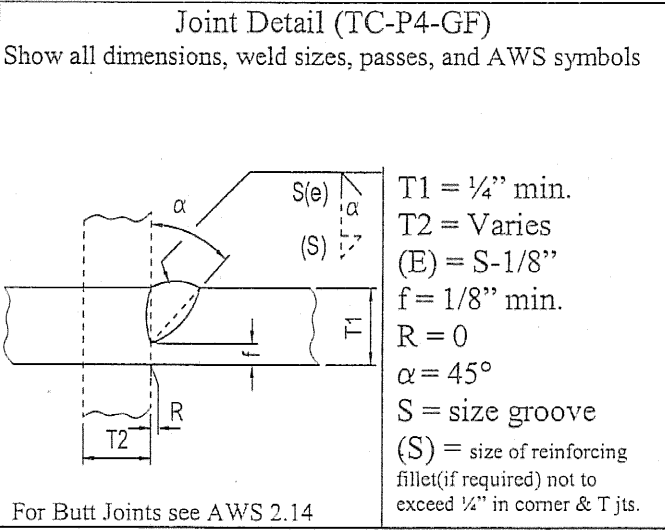

* Wire feed speed may be used along with amperage (include chart)

Prepared By: <u>[Signature]</u> DSB QA Manager	Preheat and Interpass Temperature Chart		
	Base Metal Thickness range	Minimum Preheat (°F)	Max Preheat & Interpass (°F)
Project: _____	≤3/4"	50°F	450°F
DSB Job: <u>23215-1112-VT</u>	>3/4" to ≤1.5"	70°F	450°F
Note: When this procedure is used for A709Gr50W materials, it shall be limited to 5/16" single pass or material be coated.	>1.5" to ≤2.5"	150°F	450°F
	>2.5"	225°F	450°F