

BEAM	MIN. GAGE	TENSILE STRENGTH (LBS)	RAIL OR JOINT BEAM STRENGTH	
			TRAFFIC FACE UP	TRAFFIC FACE DOWN
STANDARD	12	80,000	1500 LOAD (LBS) 2000 MAXIMUM DEFLECTION (INCHES)	1200 LOAD (LBS) 1600 MAXIMUM DEFLECTION (INCHES)
HEAVY DUTY	10	100,000	2000 LOAD (LBS) 3000 MAXIMUM DEFLECTION (INCHES)	1800 LOAD (LBS) 2400 MAXIMUM DEFLECTION (INCHES)

STRENGTH - THE RAIL ELEMENT SHALL BE DESIGNED TO MEET THE REQUIREMENTS OF THE ABOVE TABLE. THE POST CONNECTION SHALL WITHSTAND A 5000 POUND SIDE FALL IN EITHER DIRECTION. STANDARD STEEL BEAM TO BE 12 GAUGE AND THE HEAVY DUTY TO BE 10 GAUGE.

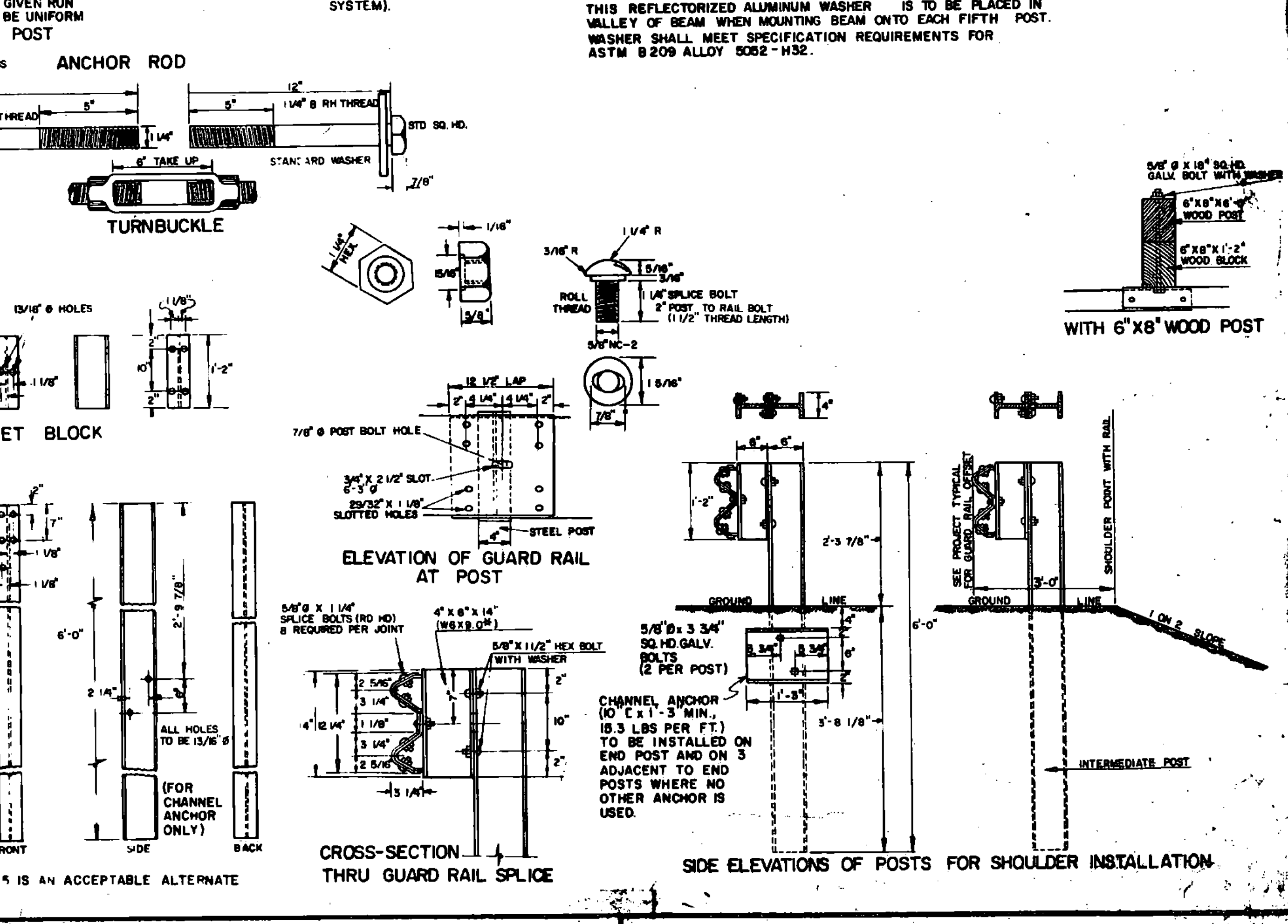
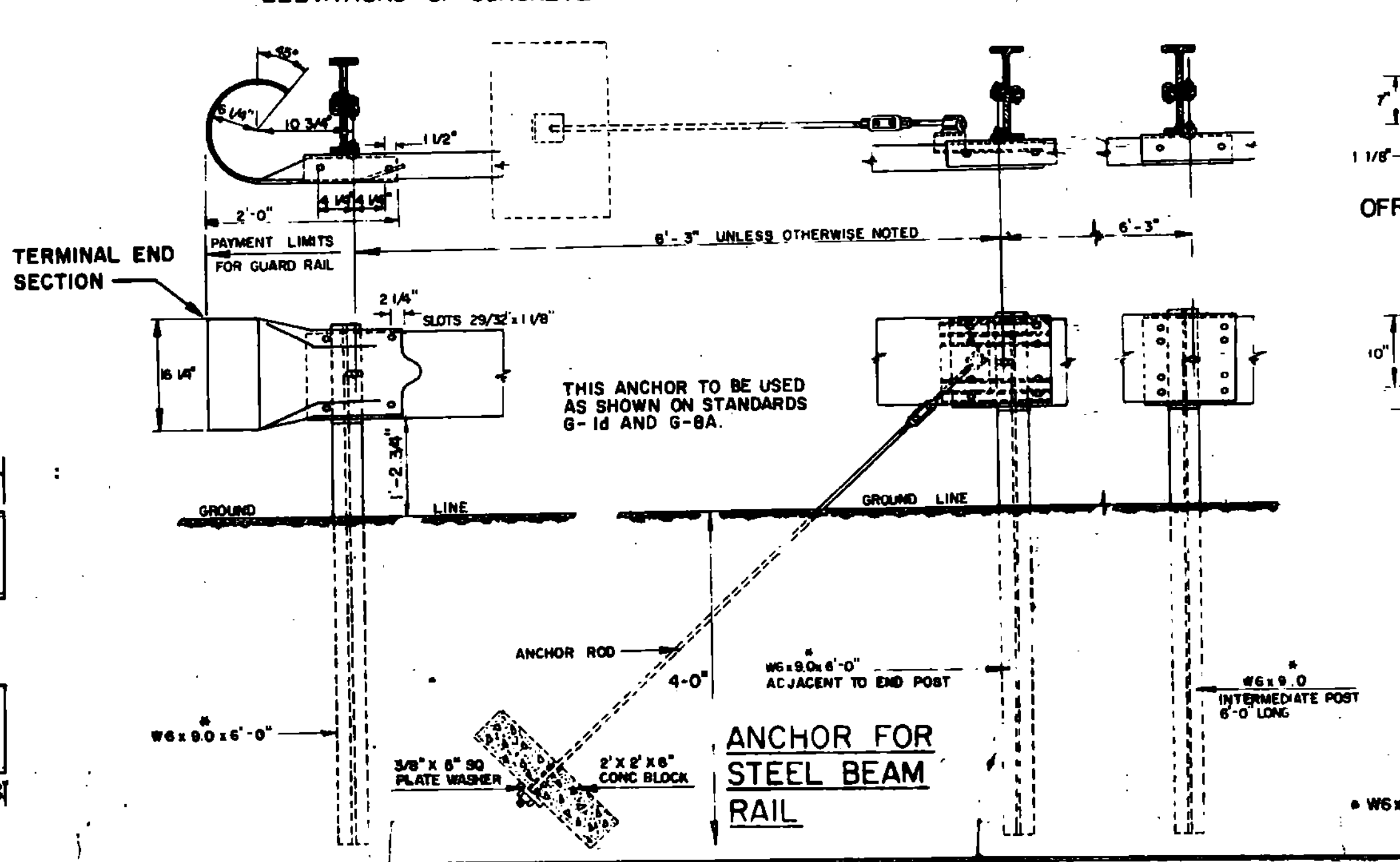
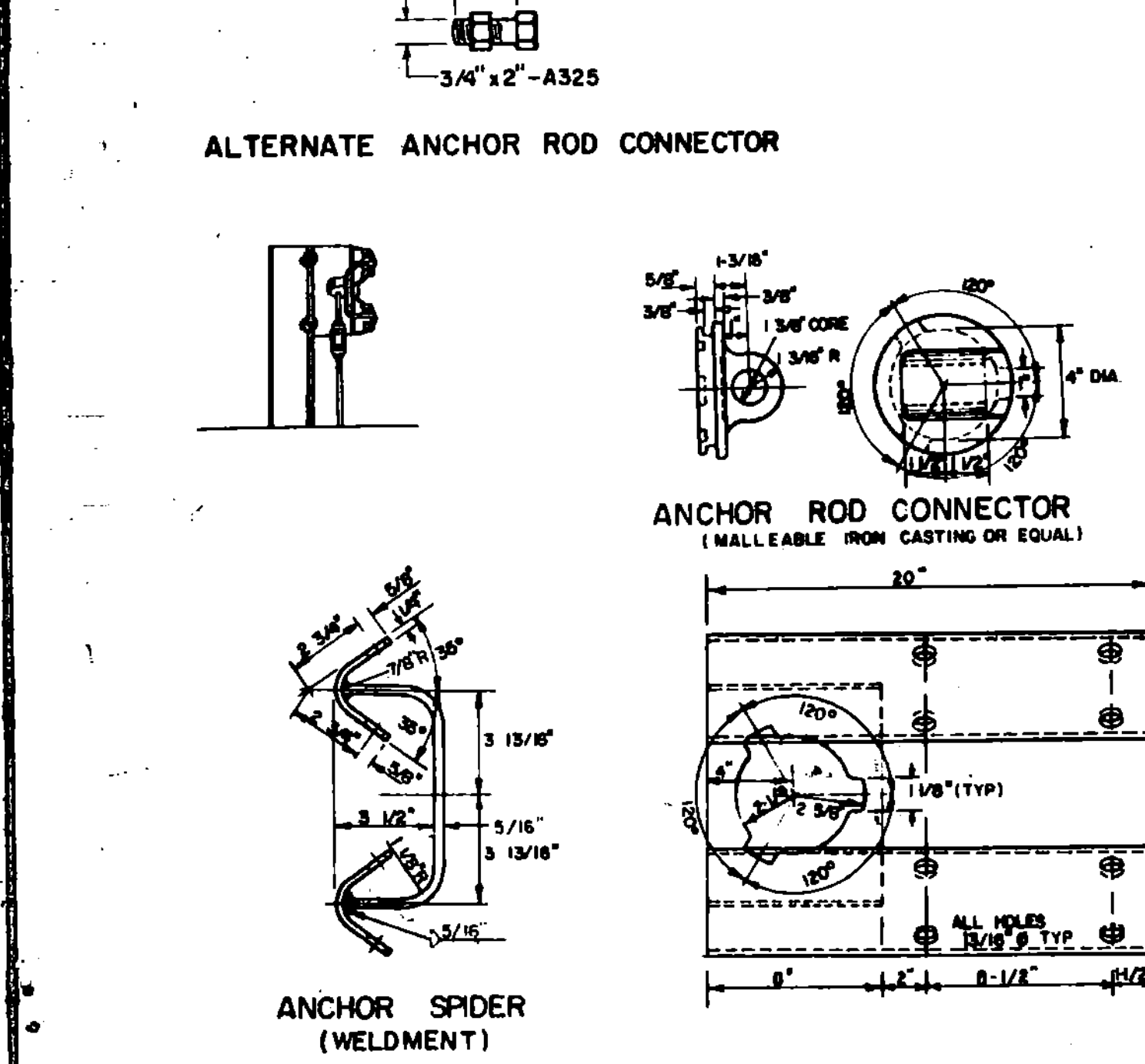
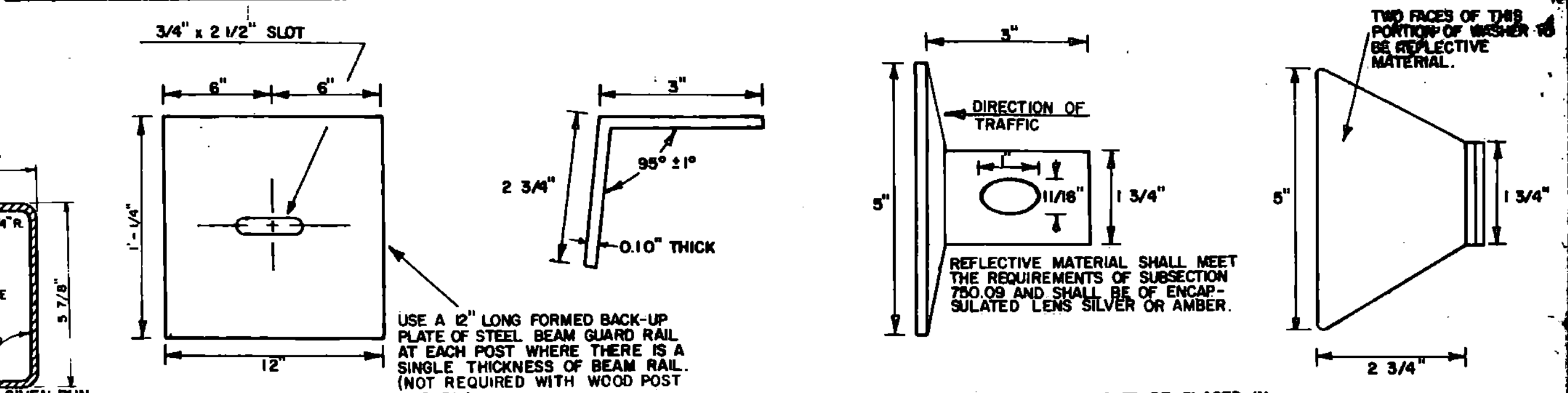
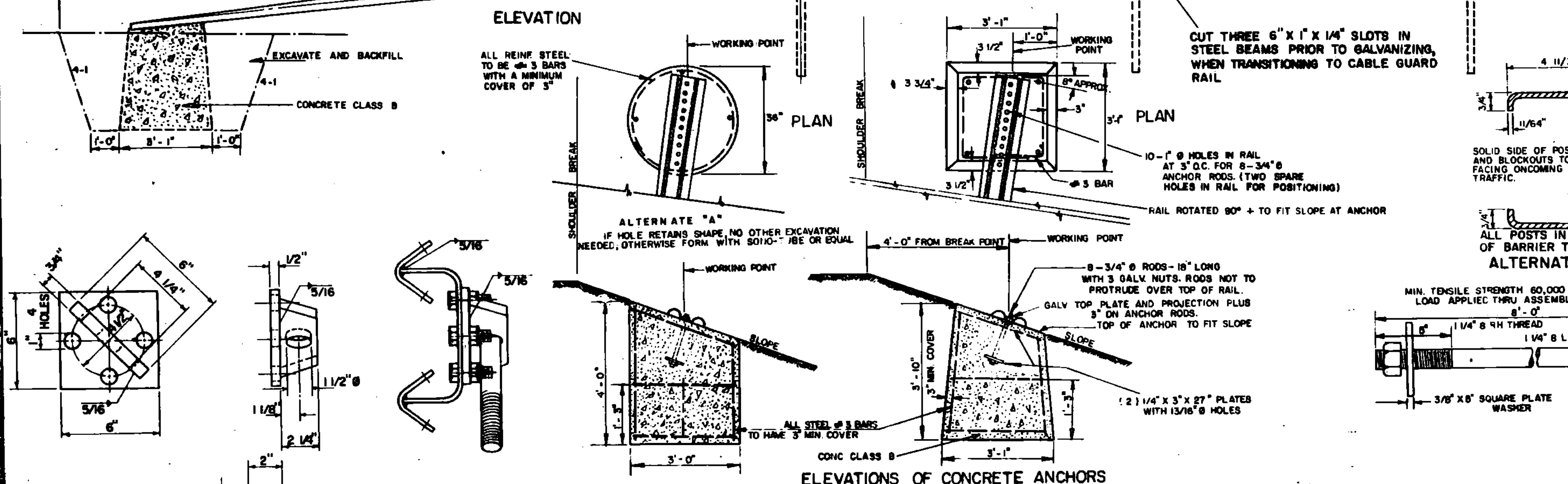
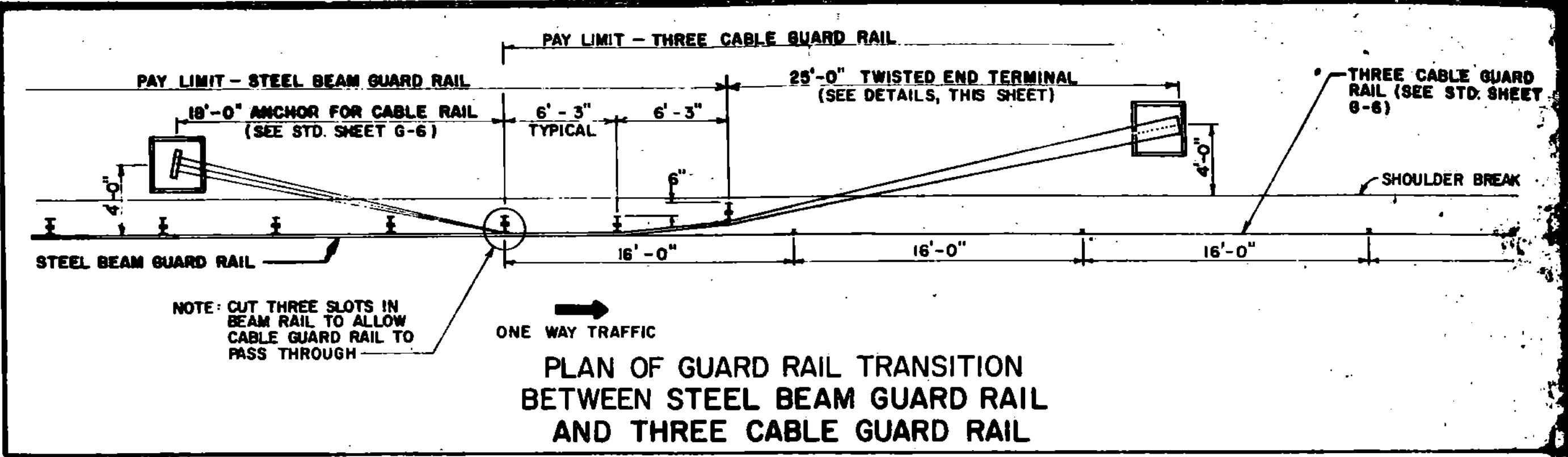
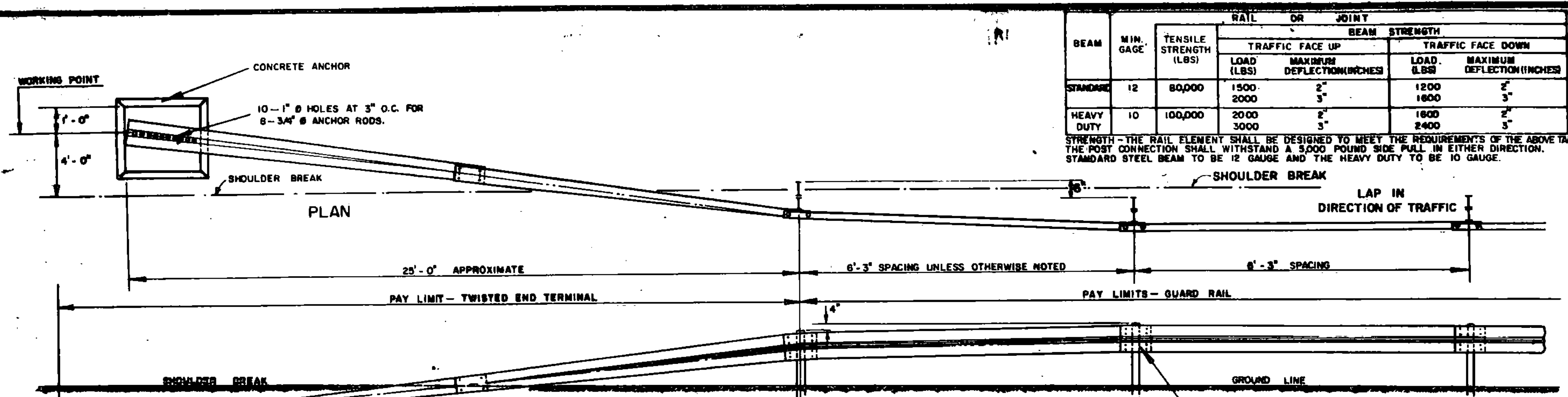

REVISIONS AND CORRECTIONS

APR. 10, 1972	POST HEIGHT INCREASED
JULY 9, 1973	NEW TRANSITION DETAIL ADDED
JUNE 4, 1974	TRANSITION REVISED, ALTERNATE ANCHOR ROD CONNECTOR AND ALTERNATE POST ADDED.
NOV. 29, 1977	ANCHOR DETAIL FOR STEEL BEAM GUARD RAIL WITH STEEL OR WOOD POSTS REMOVED.
JAN. 17, 1978	REVISED ANCHOR DETAIL.
JUNE 1, 1978	CHANNEL ANCHOR DETAILS CHANGED.
MAY 28, 1979	NOTE ON REFLECTIVE MATERIAL CHANGED
DEC. 18, 1980	INCREASED SHOULDER WIDENING FOR GUARD RAIL.
MAR 12, 1984	REVISED ANCHOR SPIDER DETAILS
JUNE 5, 1984	POST SIZE AND BACK UP PLATE NOTE CHANGED
DEC. 21, 1984	REMOVED POST WASHER
OCT. 31, 1985	REVISED TO CONFORM WITH 1986 SPECIFICATIONS

APPROVED: *Doc B. 911*

R. W. Arnold
CHIEF ENGINEER

E. H. Stehney
ASST. CHIEF ENGINEER

L. M. Lane
HIGHWAY ENGINEER

STEEL BEAM GUARD RAIL
HEAVY DUTY STEEL BEAM GUARD RAIL
TWISTED END TERMINAL
ANCHOR FOR STEEL BEAM RAIL

VERMONT AGENCY

STANDARD

G-1