

SIDE VIEW

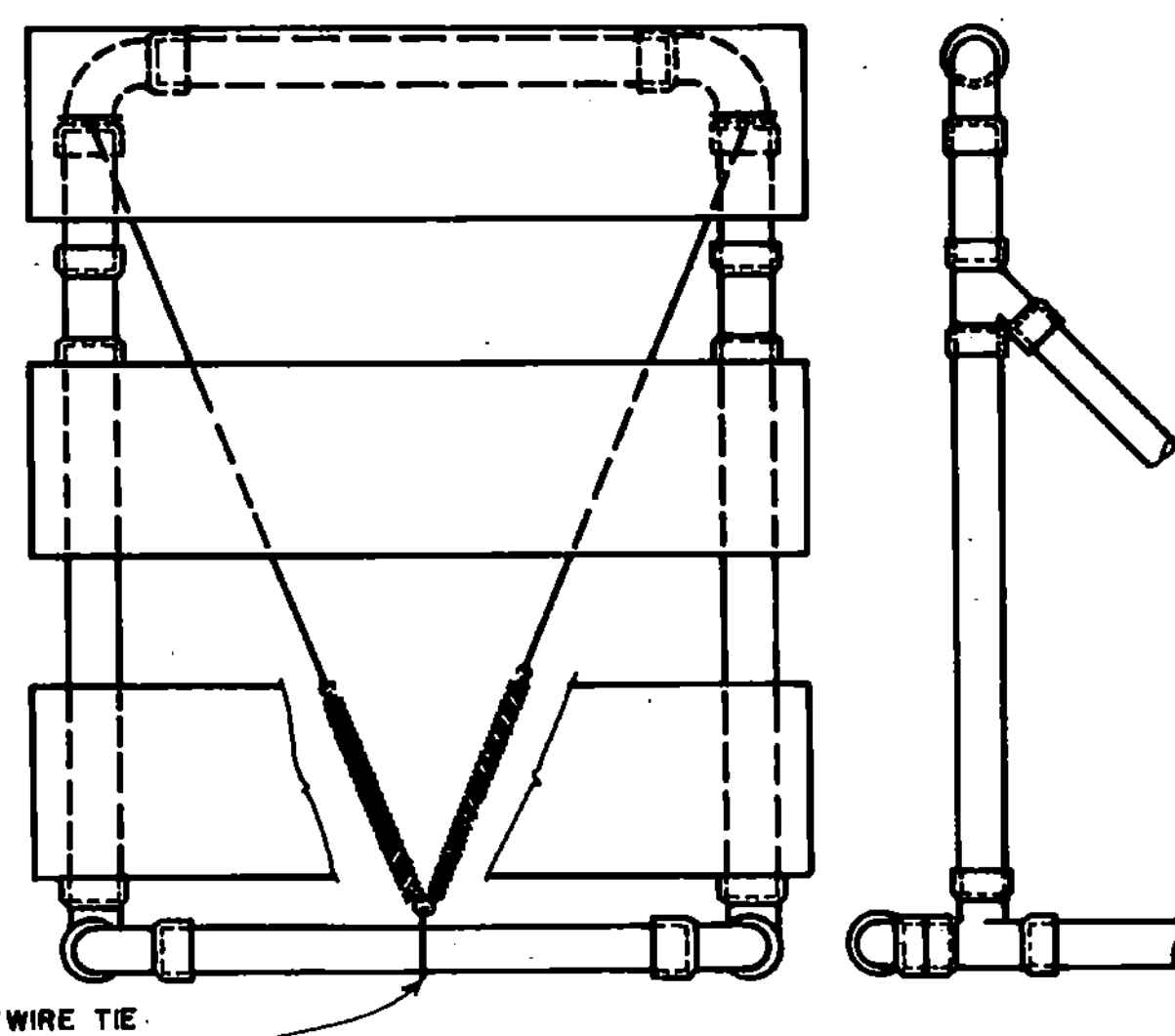

FRONT VIEW

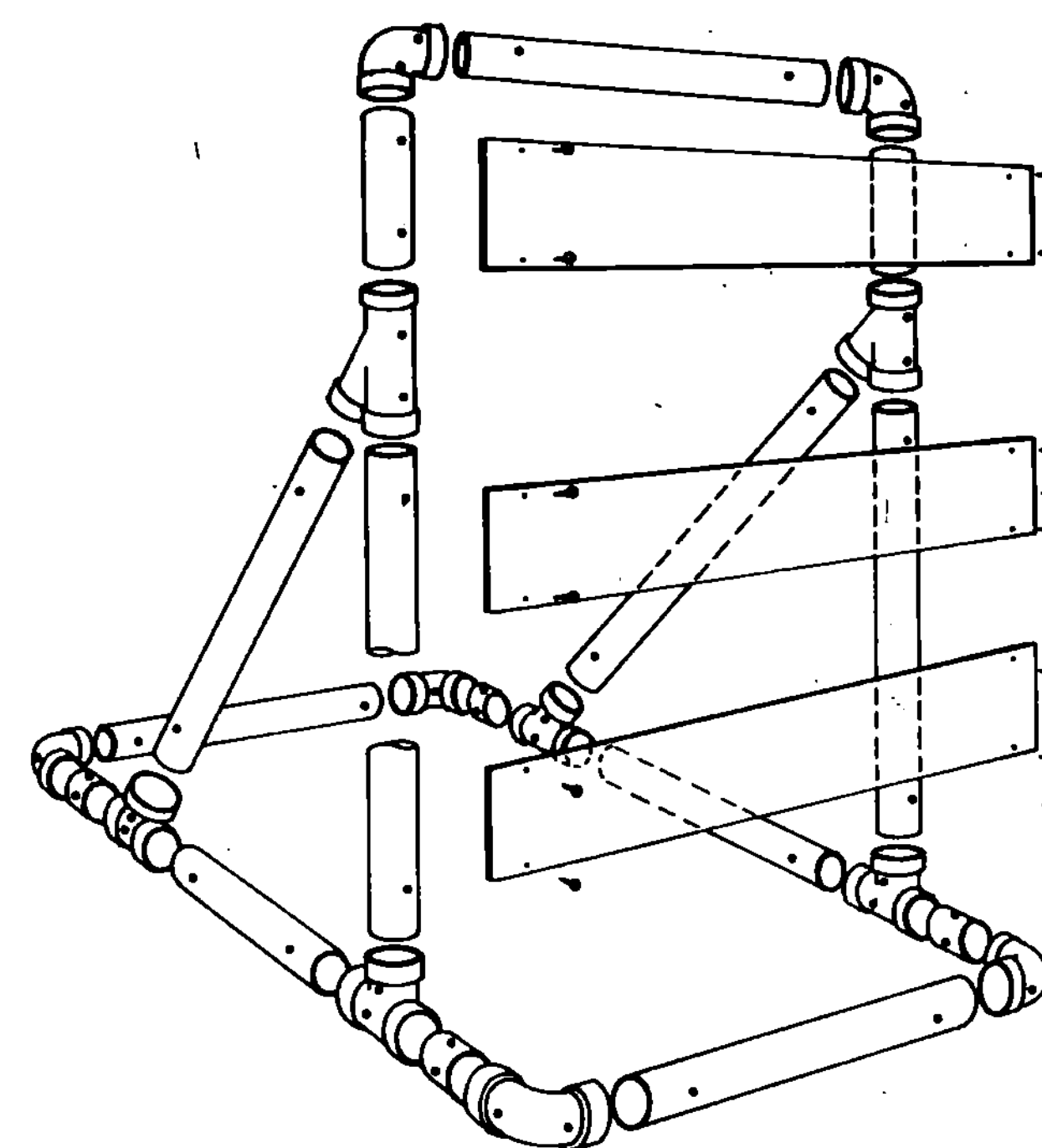

BARRICADE ASSEMBLY

MATERIALS LIST FOR ONE BARRICADE

3" Diameter Pipe	30 LF
3" 1/4 Bend Elbow	6 EA
3" Tees	2 EA
3" Wyes	4 EA
8" x 48" x .025 Barricade Panels	2 EA
5/8" x 11" No. 8 Spring	2 EA
1" No. 14 Pan Head Metal Screws	12 EA
No. 14 Black Annealed Tie Wire	15 LF

WARNING LIGHTS

WARNING LIGHTS, IF REQUIRED BY THE PLANS OR RESIDENT ENGINEER, SHALL BE AFFIXED TO THE TOP OF THESE BREAKAWAY BARRICADES WITH A MINIMUM MOUNTING HEIGHT OF 36 INCHES TO THE BOTTOM OF THE LENS. A FLASHING WARNING LIGHT SHOULD BE PLACED ON BARRICADES USED SINGLY AND STEADY BURN WARNING LIGHTS SHOULD BE PLACED ON BARRICADES USED IN A SERIES FOR TRAFFIC CHANNELIZATION. THE WARNING LIGHTS SHALL CONFORM TO THE REQUIREMENTS FOUND IN THE M.U.T.C.D. WHEN THE INTEGRAL WARNING LIGHT UNIT IS USED, THE BATTERY PACK SHALL CONTAIN A LIGHT WEIGHT DRY CELL BATTERY AND THE UNIT SHALL BE RESTRAINED WITH A TETHER CABLE OR WIRE (12' LENGTH) SECURELY FASTENED TO THE BARRICADES SO AS TO AVOID HAVING THE UNIT BECOME A DANGEROUS FLYING OBJECT IF THE BARRICADE IS HIT.

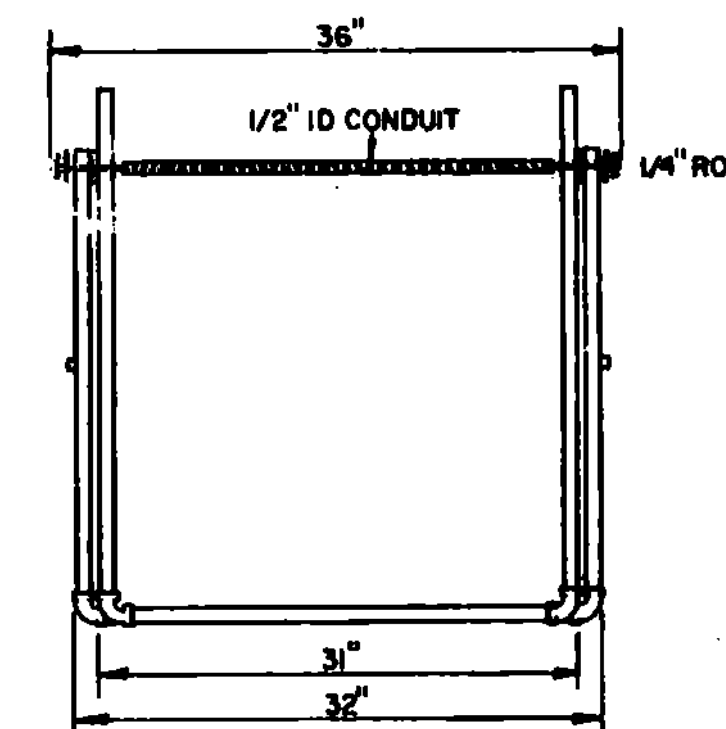

- MATERIALS FOR TYPE I & II BARRICADES
- 20'-1" PVC
 - 4-1" PVC 90° ELBOWS
 - 30'-1/2" ID THINWALL CONDUIT
 - 36'-1/4" STEEL ROD
 - 4-1" WASHERS
 - 24'- LIGHT DUTY CHAIN
 - 4-METAL SCREWS
 - 2-3/4" COTTER PINS

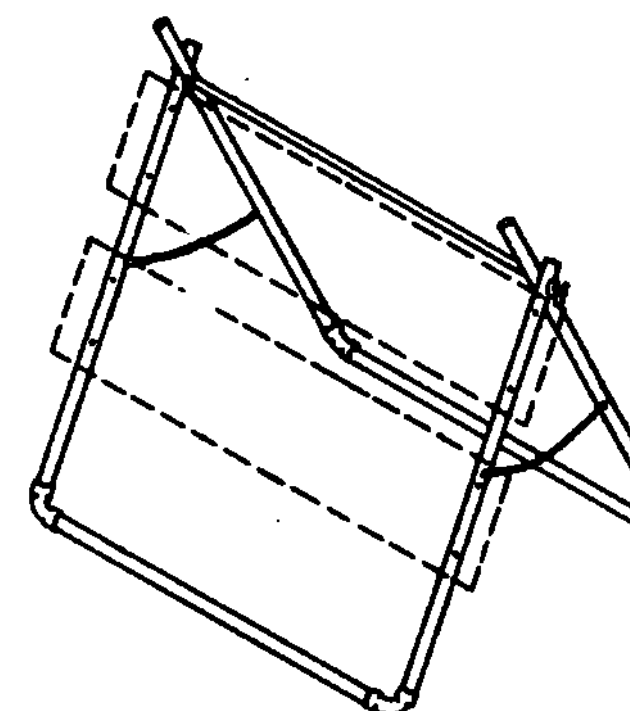
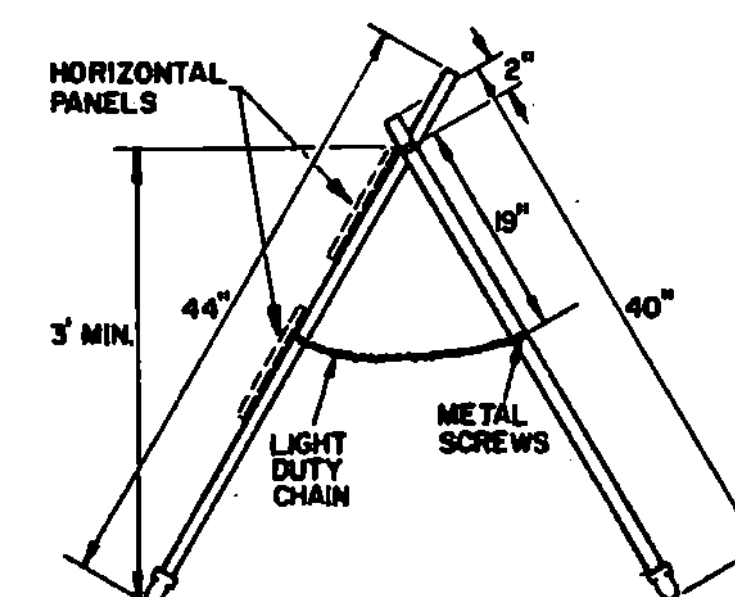

TYPE I & II BARRICADE DETAILS

TYPE I BARRICADES SHALL CONSIST OF ONE HORIZONTAL PANEL.
TYPE II BARRICADES SHALL CONSIST OF AN ADDITIONAL HORIZONTAL PANEL MOUNTED BELOW THE OTHER.
SEE STD E-7 FOR USE REQUIREMENTS.

BARRICADES SHALL BE STABILIZED WITH SAND BAGS OF MINIMUM WEIGHT WHICH WILL NOT CONSTITUTE A HAZARD WHEN BARRICADE IS HIT. THEY SHALL BE PLACED ONLY ON THE BASE FRAME OF THE BARRICADE. STABILIZERS SHALL BE SO PLACED AS NOT TO BE A HAZARD TO VEHICLES PASSING ON EITHER SIDE.

IF BARRICADE REPLACEMENT COSTS CAN BE CONSIDERED NEGLIGIBLE, GLUED JOINTS MAY PROVIDE ADDITIONAL STABILITY TO THE INSTALLATION.

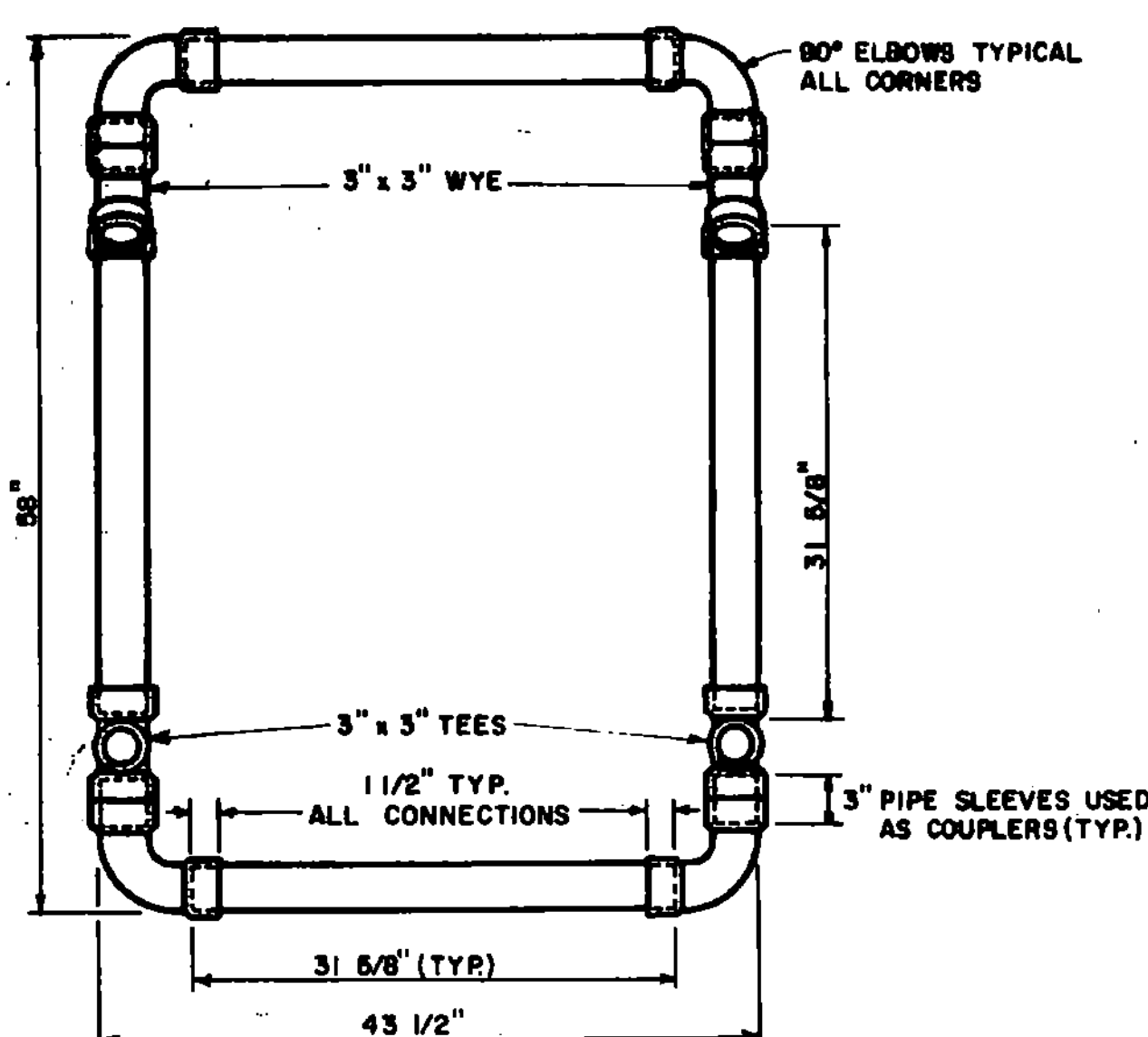

TOP VIEW OF BASE

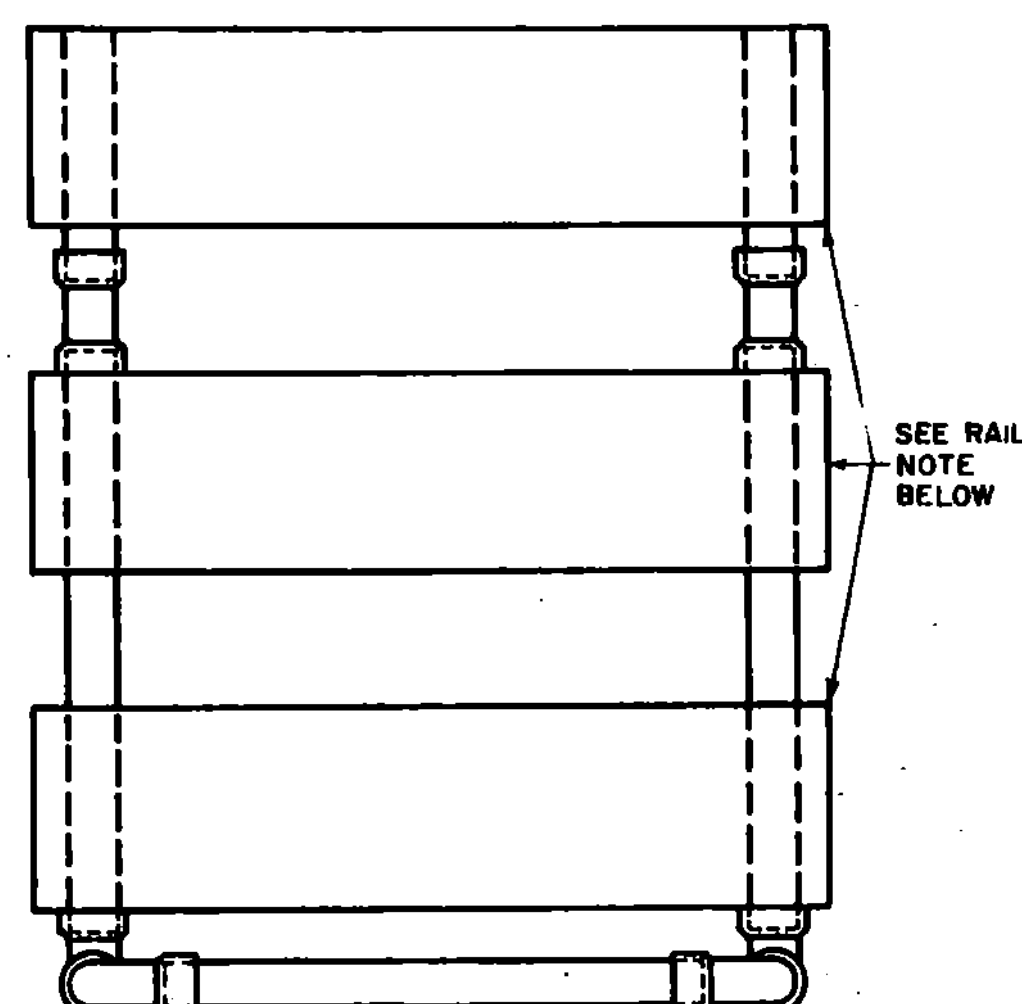

SEE STANDARD E-7 FOR RAIL DETAILS.
RAILS ATTACHED WITH 1" NO. 14 PAN HEAD METAL SCREW.

REVISIONS & CORRECTIONS

- JAN. 11, 1977 - REVISED ACCORDING TO FHWA REQUIREMENTS.
- JUNE 8, 1977 - MATERIALS LIST ADDED.
- APR. 6, 1982 - CEMENTING NOTE AND BARRICADES TYPE I & II ADDED.
- JUNE 13, 1984 - RAILS CHANGED FROM 9" TO 8".
- JAN. 3, 1985 - SAND AND WARNING LIGHT NOTE ADDED.
- FEB. 3, 1988 - UPDATED TO 1985 SPECIFICATIONS

APPROVED

DATE Dec 30, 1976
E.H. Stacey
 CHIEF ENGINEER
RO Munn
 ASST. CHIEF ENGINEER
Loan O'Connell
 HIGHWAY ENGINEER

TRAFFIC SIGNS

BREAKAWAY BARRICADE DETAILS

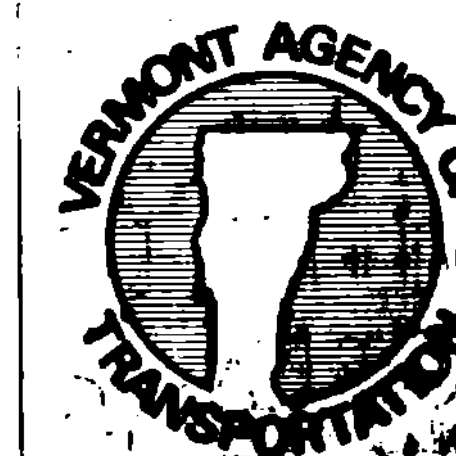

STANDARD

E-7a