

PRODUCT SPECIFICATIONS

A flexible pipe to manhole connector shall be used whenever a pipe penetrates into a precast concrete manhole or structure.

The connector shall be the **Z•LOK STM CONNECTOR** as manufactured by **A•LOK PRODUCTS, INC.**, Tullytown, PA, or approved equal.

The design of the connector shall provide a flexible, watertight seal between the pipe and concrete structure. The connector shall assure that a seal is made between:

(1) The connector and the structure wall by casting the connector integrally with the structure wall during the manufacturing process in a manner that it will not pull out during pipe coupling.

(2) The seal between the connector and the pipe shall be made by compressing the connector against the outside circumference of the smooth wall pipe or against the inside walls of the valley of the corrugated pipe by means of a stainless steel take-down clamp.

The connector shall be made from materials that conform to the physical and chemical requirements outlined in Section 4, "Materials and Manufacture" of ASTM C-923 "Standard Specification for Resilient Connectors Between Reinforced Concrete Manhole Structures, Pipes, and Laterals", and the overall design will meet or exceed Section 7, "Test Methods and Requirements" of ASTM C-923 and ASTM C-1478.

The connector shall be sized specifically for the type of pipe being used and shall be installed in accordance with the recommendations of the manufacturer.

FIELD INSTALLATION INSTRUCTIONS

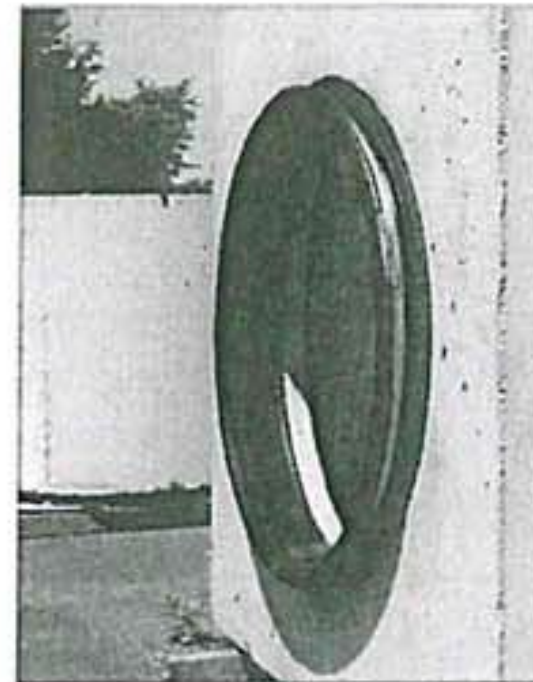

CORRUGATED PIPE

FIELD INSTALLATION

STEP 1:
Z•LOK STM Connector cast into storm structure.

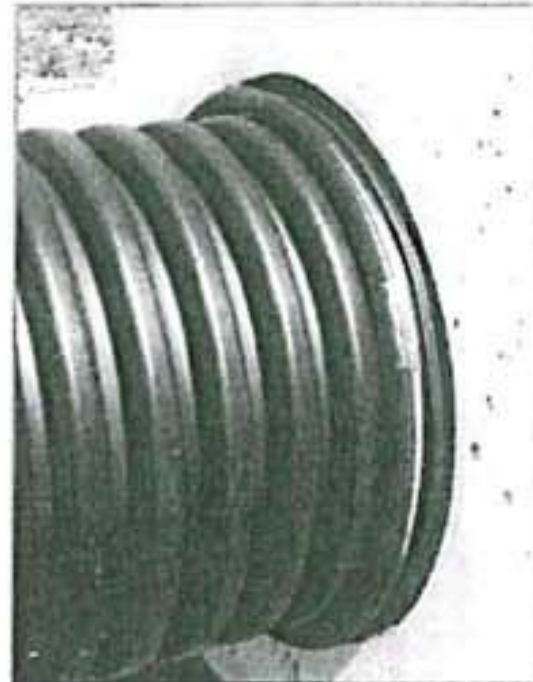

STEP 2:
Pipe is centered through the connector. The Stainless Steel Clamp is centered above the valley of pipe making sure the fastening points are positioned in the two cutout areas of the rubber connector.



STEP 3:
Stainless Steel Clamp is **tightened equally** about the take-up point to 60 in./lbs. This action compresses the rubber against the side walls of the pipe valley and a watertight connection is formed.

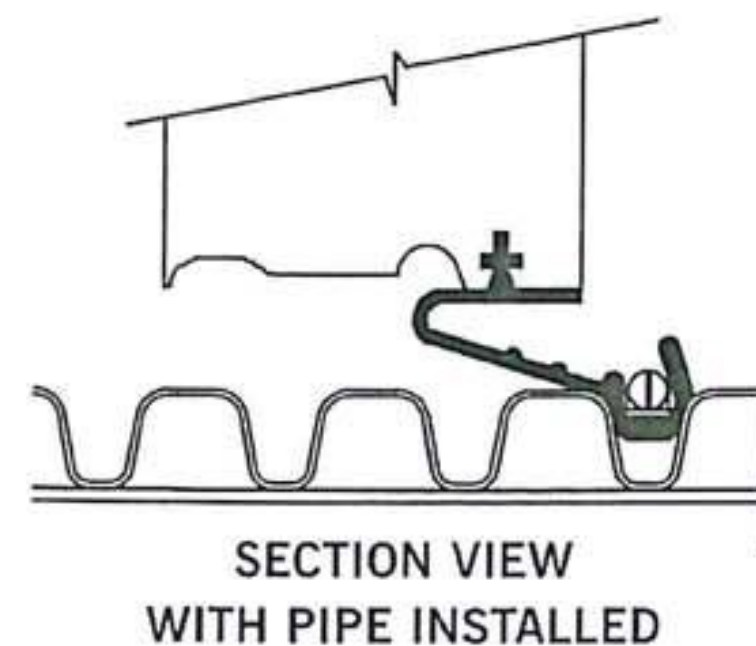

IMPORTANT: After groove of pipe is centered in gasket tighten stainless steel clamp equally to 60 in. lbs. with an A•LOK Torque Wrench.

PRECAST INSTALLATION INSTRUCTIONS

ONE-PIECE WEDGE KNOCKOUT For 6" Flatwall

Pull connector over one-piece Wedge Knockout Hole Former as shown.

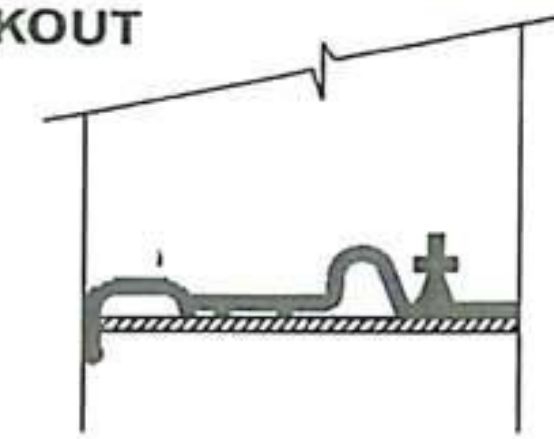

TWO-PIECE MANDREL For 8" Flatwall and above

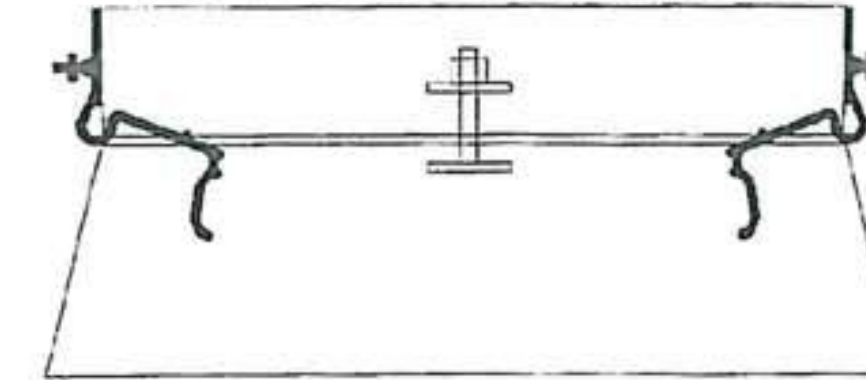

1. Stretch gasket over outside mandrel half, with cut-outs positioned at 3 and 9 o'clock.
2. Force gasket down inside mandrel before installing in form.
3. Use coil nut to tighten gasket and mandrels together.

TWO-PIECE MANDREL For Round Manholes

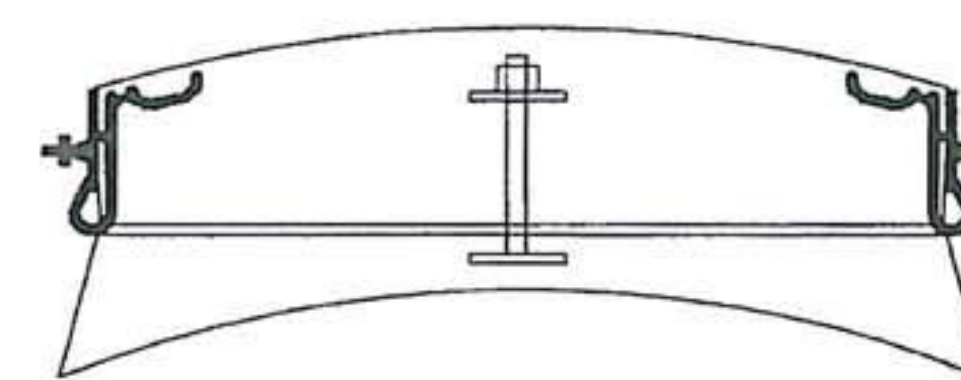

FIELD INSTALLATION INSTRUCTIONS

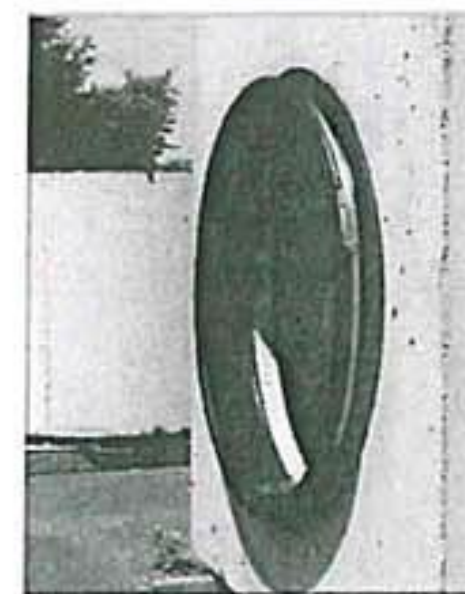

SMOOTH WALL PIPE

FIELD INSTALLATION

STEP 1:
Z•LOK STM Connector cast into storm structure.



STEP 2:
Pipe is inserted and centered within the connector to obtain proper mechanical seal.



STEP 3:
Stainless Steel Clamp is tightened equally about the take-up point to 60 in./lbs, insuring a watertight connection. This should be done prior to any pipe deflection or backfilling.

SECTION VIEW WITH PIPE INSTALLED

