

GENERAL SIGNING DETAILS

TYPE 1

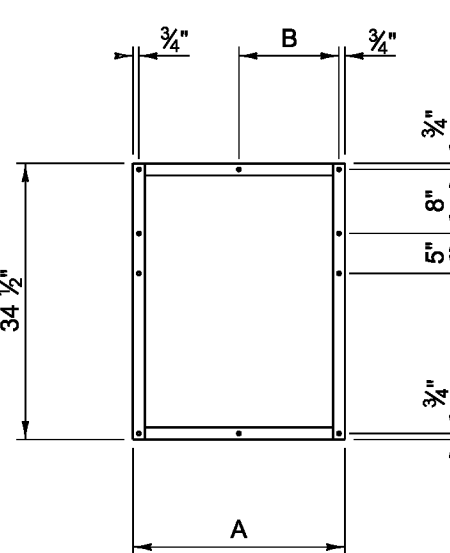

TYPE 2

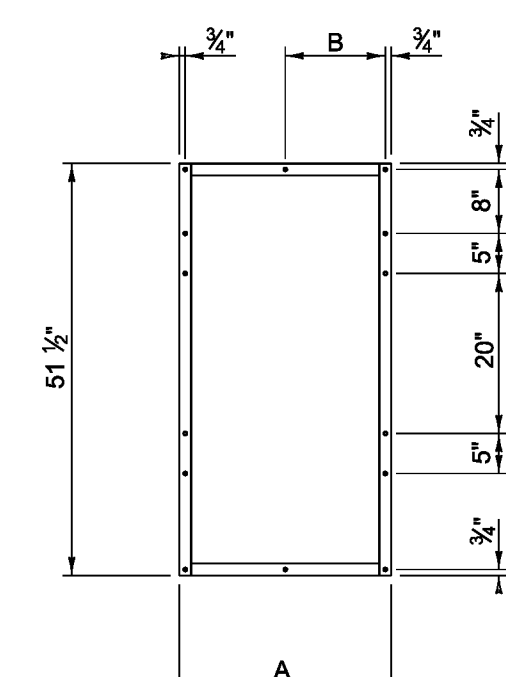

TYPE 3

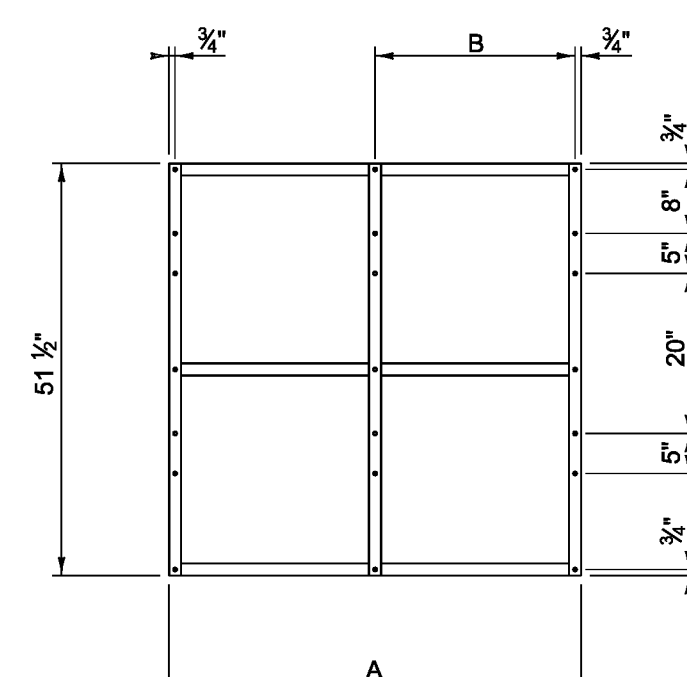

FRAME TYPE	A	B
1A	26 1/2"	12 1/2"
1B	29 1/2"	15 1/2"
1C	32 1/2"	15 1/2"

FRAME TYPE	A	B
2A	26 1/2"	12 1/2"
2B	29 1/2"	15 1/2"
2C	32 1/2"	15 1/2"

FRAME TYPE	A	B
3A	51 1/2"	25"
3B	54 1/2"	28"
3C	57 1/2"	28"
3D	63 1/2"	31"

ROUTE MARKER ASSEMBLY FRAMES

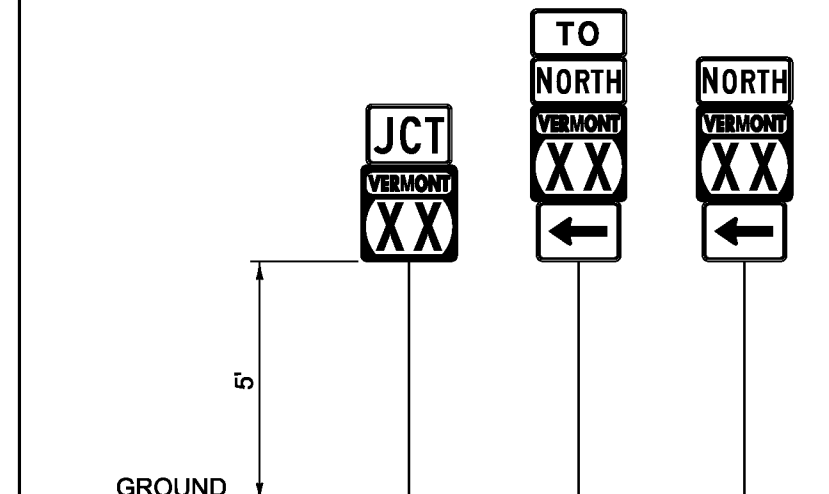

GUIDE SIGN PLACEMENT DETAIL

NOTES:

1. IN ALL URBAN AREAS AND IN RURAL AREAS WHERE PARKING OR PEDESTRIAN TRAFFIC WILL OCCUR IN THE IMMEDIATE VICINITY OF THESE SIGNS, MINIMUM VERTICAL CLEARANCE SHALL BE INCREASED TO SEVEN FEET.

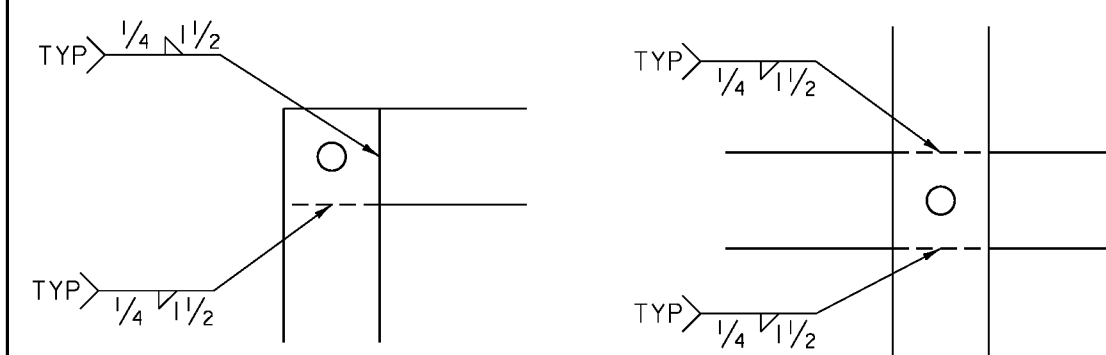

WELDING DETAILS

NOTES:

1. TYPE 1A FRAME ASSEMBLY TO BE USED WITH TWO 24 INCH WIDE SIGN COLUMNS.
2. TYPE 1B FRAME ASSEMBLY TO BE USED WITH ONE 24 INCH WIDE SIGN COLUMN AND ONE 30 INCH WIDE SIGN COLUMN.
3. TYPE 1C FRAME ASSEMBLY TO BE USED WITH TWO 30 INCH WIDE SIGN COLUMNS.
4. TYPE 2A FRAME ASSEMBLY TO BE USED WITH TWO 24 INCH WIDE SIGN COLUMNS.
5. TYPE 2B FRAME ASSEMBLY TO BE USED WITH ONE 24 INCH WIDE SIGN COLUMN AND ONE 30 INCH WIDE SIGN COLUMN.
6. TYPE 2C FRAME ASSEMBLY TO BE USED WITH TWO 30 INCH WIDE SIGN COLUMNS.
7. TYPE 3A FRAME ASSEMBLY TO BE USED WITH THREE 24 INCH WIDE SIGN COLUMNS.
8. TYPE 3B FRAME ASSEMBLY TO BE USED WITH TWO 24 INCH WIDE SIGN COLUMNS AND ONE 30 INCH WIDE SIGN COLUMN, WITH THE 30 INCH SIGN COLUMN IN AN OUTSIDE POSITION.
9. TYPE 3C FRAME ASSEMBLY TO BE USED WITH ONE 24 INCH WIDE SIGN COLUMN IN THE CENTER AND TWO 30 INCH SIGN COLUMNS ON THE OUTSIDE OR ONE 30 INCH SIGN COLUMN IN THE CENTER AND TWO 24 INCH SIGN COLUMNS ON THE OUTSIDE.
10. TYPE 3D FRAME ASSEMBLY TO BE USED WITH THREE 30 INCH WIDE SIGN COLUMNS.
11. ALL HOLES SHALL BE 7/16 INCH DIAMETER.
12. FOR SIGN COMBINATIONS OTHER THAN ABOVE, THE FRAME DIMENSIONS AND HOLE SPACING SHALL BE MODIFIED AS NECESSARY.
13. STANDARD FRAMES SHALL BE CONSTRUCTED OF 3/16 INCH BY 1 1/2 INCH STEEL MEETING THE REQUIREMENTS OF AASHTO M 270/M 270, GRADE 250 (GRADE 36).
14. SEE THE MANUAL ON UNIFORM TRAFFIC CONTROL DEVICES (MUTCD) SECTION 2D.29 FOR INSTALLATION SEQUENCE.
15. ALL DIMENSIONS SHOWN IN INCHES, UNLESS OTHERWISE NOTED.

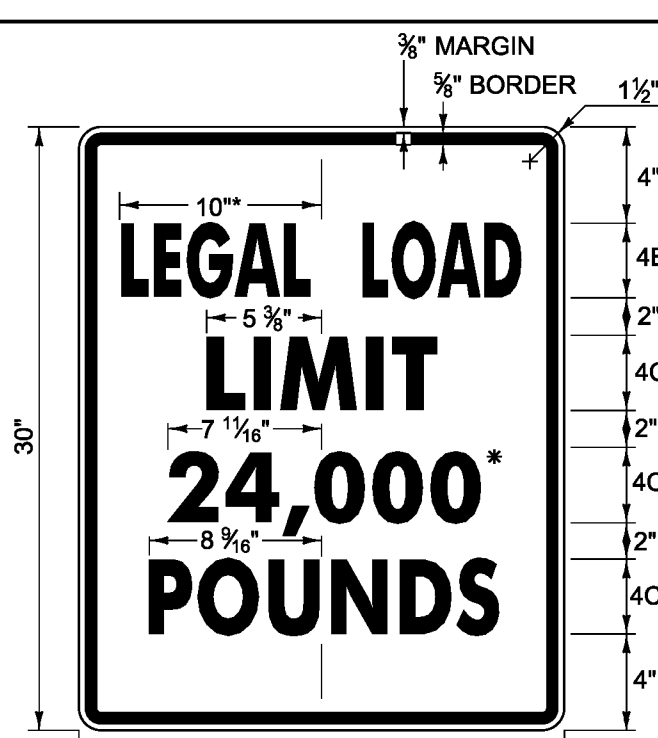
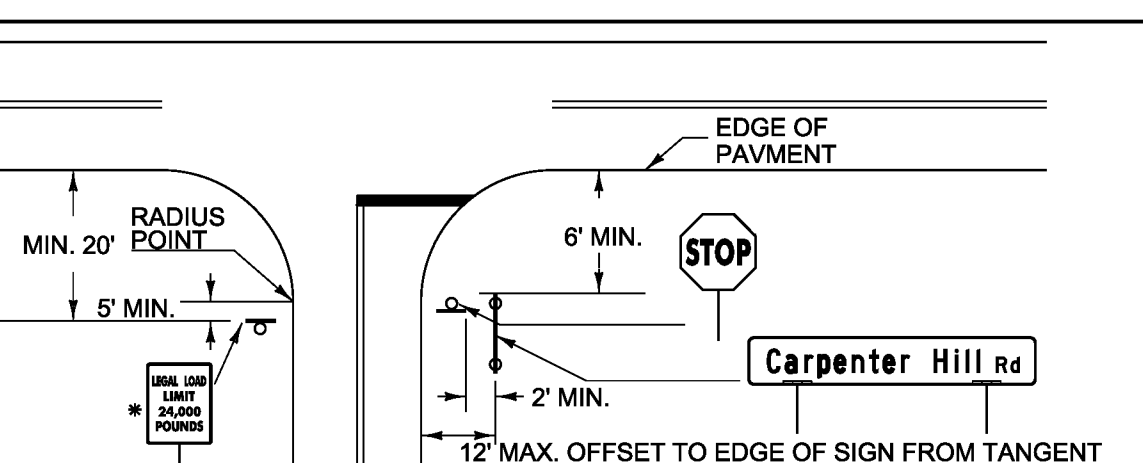

1. SIDE ROAD STREET NAME SIGNS, COMMONLY INSTALLED PERPENDICULAR TO THE APPROACHING MAINLINE TRAFFIC, SHALL BE POSITIONED IN SUCH A WAY AS TO ENSURE THE BEST POSSIBLE VISIBILITY TO APPROACHING MAINLINE TRAFFIC FROM EACH DIRECTION. IN MOST CASES, STREET NAME SIGNS MAY BE INSTALLED ABOVE THE SIDE ROAD STOP SIGN. IN CASES WHERE THE SIDE ROAD STOP SIGN POSITION WOULD NOT BE SUITABLE FOR A TOP-MOUNTED STREET NAME SIGN, OR OTHER SITE-SPECIFIC CONSTRAINTS, THE STREET NAME SIGNS MAY BE INSTALLED INDEPENDENTLY ON EITHER CORNER OF THE INTERSECTION. THE STREET NAME SIGN(S) SHALL BE INSTALLED A MINIMUM OF SIX FEET FROM THE EDGE OF PAVEMENT FROM THE EDGE OF THE MAINLINE ROUTE TO THE NEAREST EDGE OF THE SIGN.
2. STREET NAME SIGNS WITH A LENGTH EXCEEDING 42-INCHES SHALL BE INSTALLED ON TWO POSTS, UNLESS PROTECTED BY BARRIER. THIS TWO POST ASSEMBLY SHALL BE LATERALLY OFFSET A MINIMUM OF TWO FEET (IN THE DIRECTION OF THE MAINLINE TRAFFIC) FROM ANY OTHER SIGN POST; NO MORE THAN TWO POSTS SHALL OCCUPY AN EIGHT FOOT PATH, UNLESS PROTECTED BY BARRIER.
3. TOP-MOUNTED STREET NAME SIGNS SHALL REQUIRE 12-INCH MOUNTING BRACKETS. ALL MOUNTING HARDWARE IS INCIDENTAL TO PAY ITEM 675.20 (TRAFFIC SIGN, TYPE A).
4. IF EXISTING STREET NAME SIGNS ARE SALVAGED THEY SHALL BE RE-INSTALLED PER THE ABOVE NOTES OR AS DIRECTED BY THE ENGINEER.
5. STREET NAME SIGNS FOR PRIVATE ROADS SHALL BE RETAINED, UNLESS OTHERWISE NOTED OR AS DIRECTED BY THE ENGINEER.
6. THE STOP SIGN SHALL BE INSTALLED ON THE DRIVER'S RIGHT. MAINTAIN MAXIMUM VISIBILITY. THE STOP SIGN DOES NOT HAVE TO BE ADJACENT TO THE STOP BAR.
7. THE LEGAL LOAD LIMIT MAY VARY IN WEIGHT ACCORDING TO ROADWAY CONDITIONS, THE SIDE ROAD SPEED LIMIT MAY BE INSTALLED BELOW THE LEGAL LOAD LIMIT SIGN AS REQUIRED.

LEGAL LOAD LIMIT AND STOP SIGNS AT INTERSECTIONS WITH TOWN HIGHWAYS

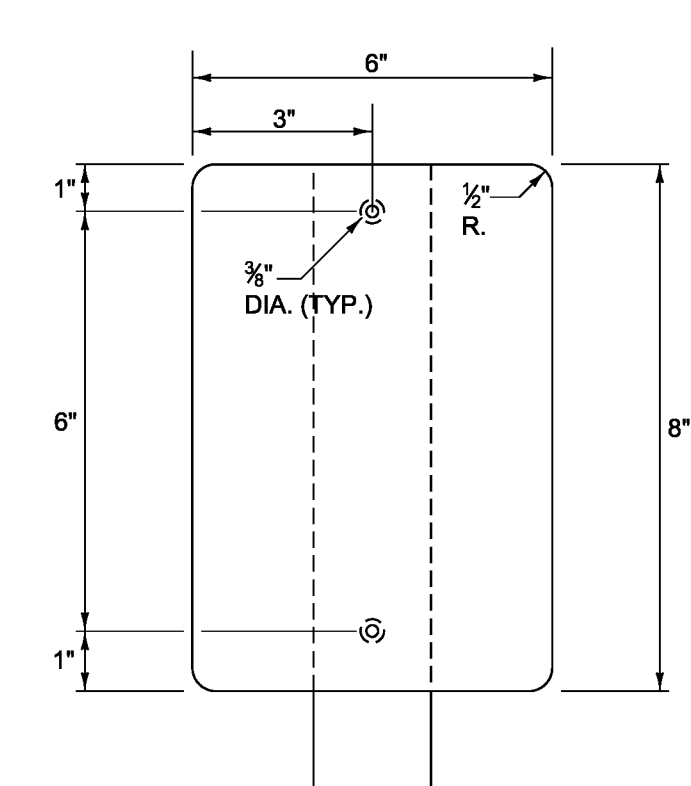

TYPE II (6'x8') DELINEATOR
BACK-TO-BACK DELINEATORS WITH RETROREFLECTIVE SHEETING

NOTES:

1. MATERIAL FOR RETROREFLECTIVE SHEETING FOR DELINEATORS SHALL BE A 0.063" ALUMINUM BACKING WITH A WHITE ASTM TYPE III OR TYPE IV.
2. ALL TYPE II (6'x8') DELINEATOR POSTS SHALL BE 1.88 LB/FT SQUARE STEEL WITH A 12 GAGE ANCHOR, WITH AN ANCHOR REVEAL OF TWO INCHES.
3. DELINEATOR POSTS SHALL HAVE A MINIMUM EMBEDMENT OF 2'-6" IN THE GROUND.
4. ALL WORK ASSOCIATED WITH TYPE II (6'x8') DELINEATORS SHALL BE PAID FOR UNDER CONTRACT ITEM 676.10 DELINEATOR WITH STEEL POST.

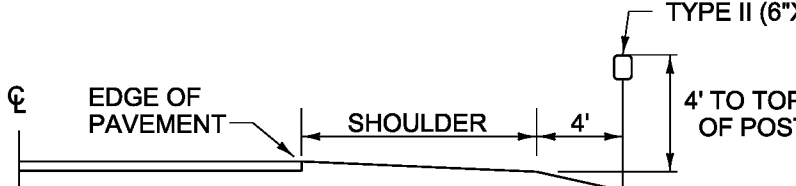

DELINEATOR PLACEMENT

PROJECT NAME:	STATEWIDE SOUTHWEST REGION
PROJECT NUMBER:	STP HRRR(15) / HES HSIP(6)
FILE NAME:	t12k024fr.m.dgn
PROJECT LEADER:	JLS
DESIGNED BY:	MBL
GENERAL SIGN DETAIL SHEET I	
PLOT DATE:	06-AUG-2012
DRAWN BY:	MBL
CHECKED BY:	NA
SHEET	4 OF 90