

WW 3
 (ITEM # 16)

PLAN VIEW

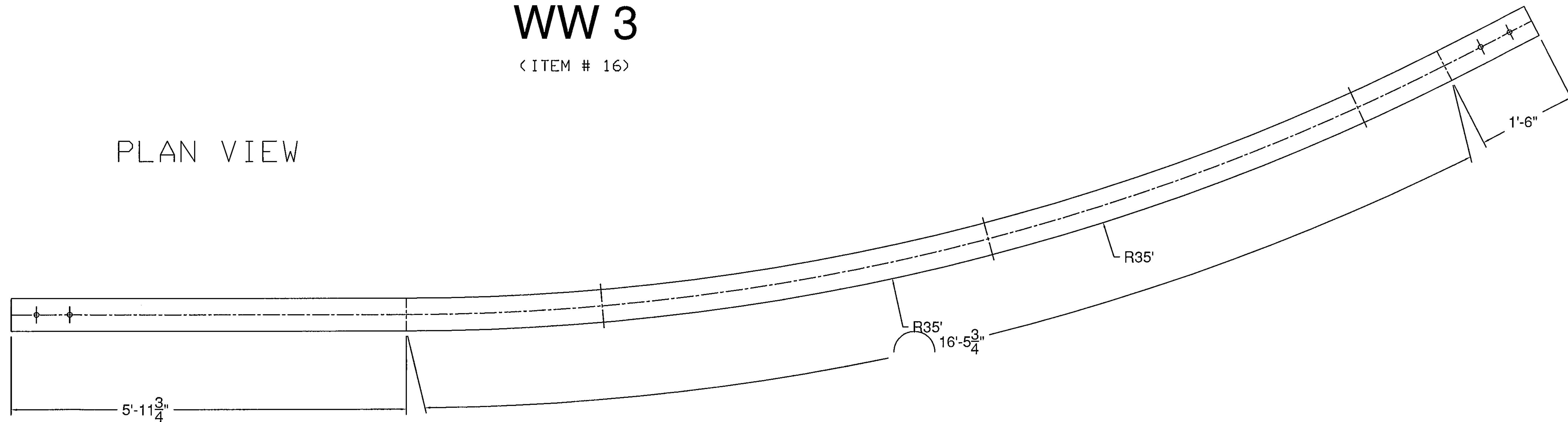

900.620 SPECIAL PROVISION (GUARDRAIL)
 ITEM #: APPROACH SECTION TO CONCRETE BRIDGE RAIL

SHEET 12 OF 12

Vermont Agency of Transportation
RECEIVED
 CK'D BY SC, RF OK'D BY G. Laroche
 April 8, 2016
 RESUBMIT No Approved
 BY K. Higgins DATE 04/11/2016

STRUCTURAL STEEL TO COMPLY W/ ASTM A6
 TOLERANCE UNLESS OTHERWISE NOTED:
 FRACTIONS = ± 1/16"
 ANGLES = ± 1/2"
 DIAMETERS = ± 1/32"

SPECIAL PROVISION, GRAS - CONCRETE COMBINATION BR.
 ROUTE NO. T.H. 3 (CLASS 2), RURAL COLLECTOR, BRIDGE # 11
 TOWN OF CLARENDON, RUTAND COUNTY, VT.

R NO.	DATE	DESCRIPTION	BY	R NO.	DATE	DESCRIPTION	BY
E 1	3/10/16	REVISED PER 2/23/16 MARK-UP	E.P. E				
V 2	4/8/16	REVISED PER 3/22/16 MARK-UP	E.P. V				

DRAWN	E.P.	01/29/16
CHECKED	D.L.	
APPROVED	M.V.	
SCALE	SCHEMATIC	
DRAWING NO. FRL - CLARENDON - T		

ELDERLEE, INC.
 OAKS CORNERS, NEW YORK 14518
 email: dlong@elderlee.com / epsek@elderlee.com
 Tel: 315-789-6670 Fax: 315-789-6615

