

WELD TERMINATION AND COPING
DETAILS FOR STEEL MEMBERS

*NO WELD FOR 3/8" MIN. 7/8" MAX. (EXCEPT MUST MAINTAIN 1" MINIMUM FROM EDGE OF FLANGE)

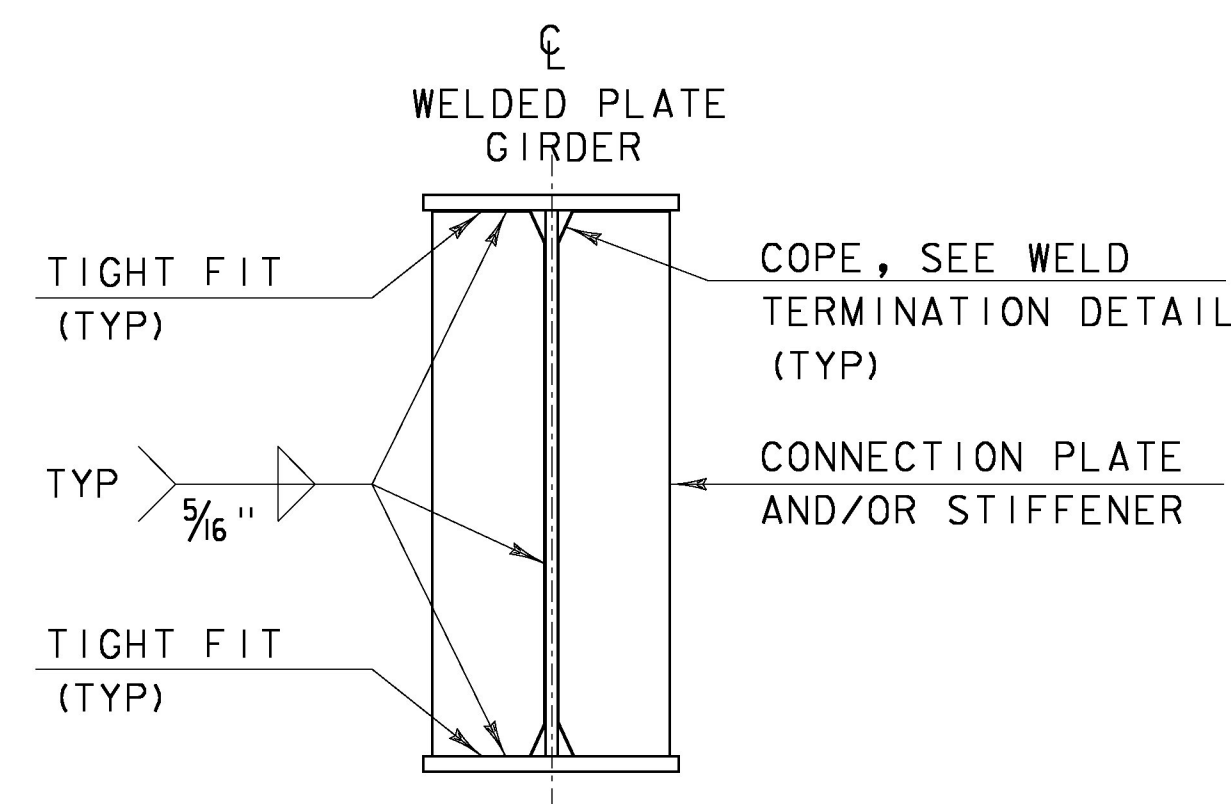

INTERMEDIATE CONNECTION PLATES
AND/OR STIFFENERS FOR WELDED
PLATE GIRDERS

INTERMEDIATE DETAIL IS ONLY USED WHEN PLATE DOES NOT OCCUR AT AN ABUTMENT OR PIER.

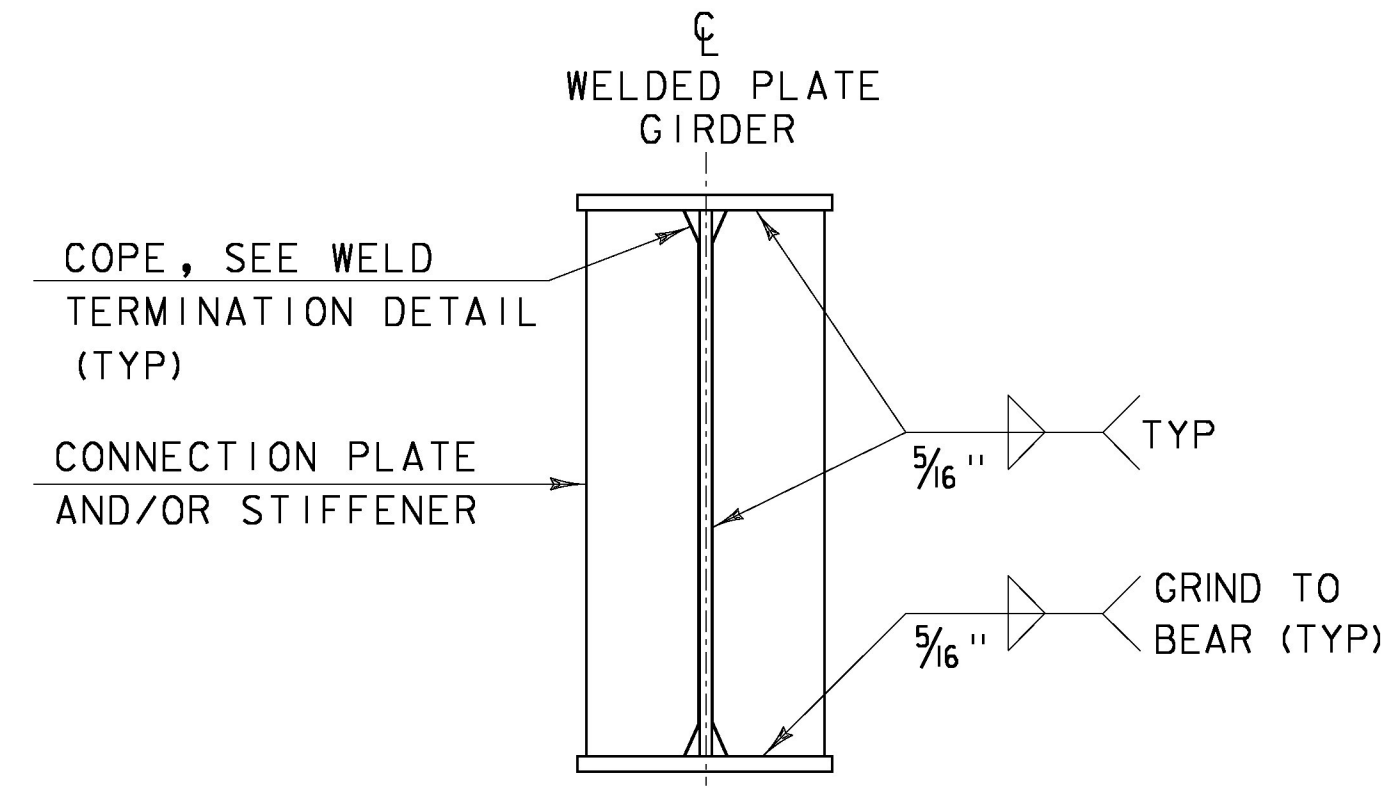

ABUTMENT BEARING STIFFENERS
AND/OR CONNECTION PLATES
FOR WELDED PLATE GIRDERS

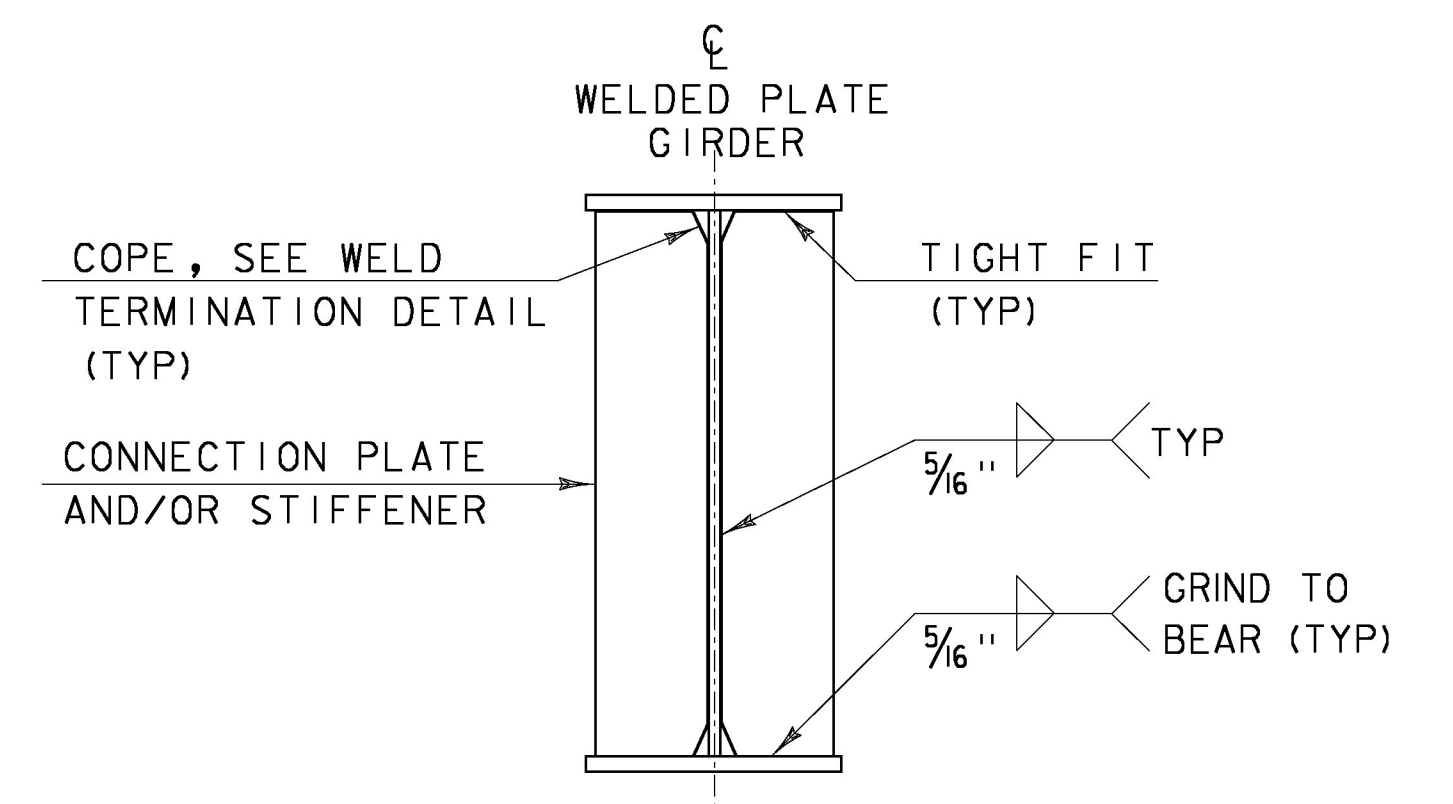

PIER BEARING STIFFENERS
AND/OR CONNECTION PLATES
FOR WELDED PLATE GIRDERS

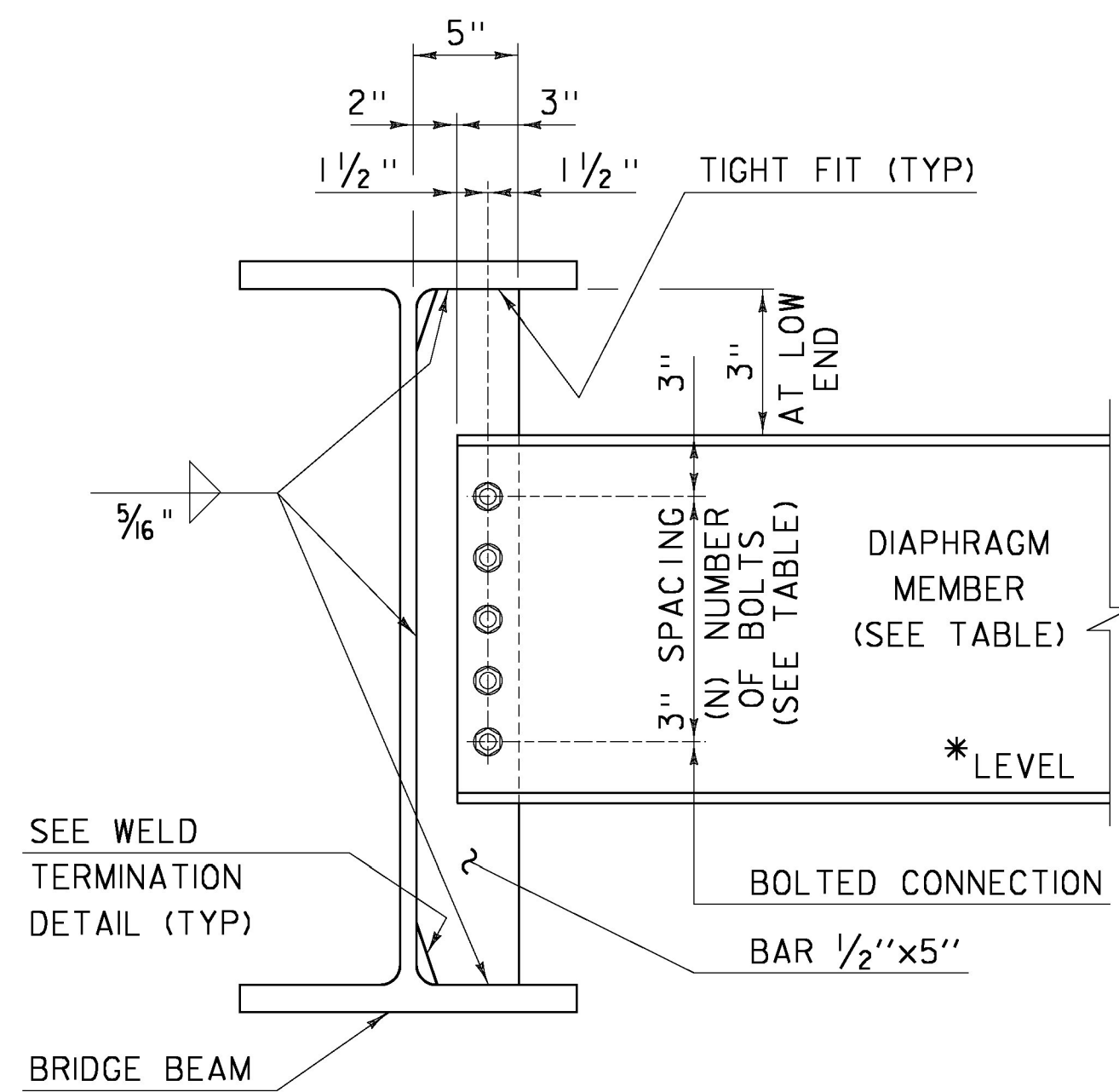

INTERMEDIATE DIAPHRAGMS
FOR 24" TO 48" BRIDGE BEAMS

* IF CLEARANCE CANNOT BE MET, DIAPHRAGM MAY BE SLOPED.

	DEPTH	DIAPHRAGM MEMBER	(N) BOLTS
ROLLED BEAM	24"	C15x33.9	4
	30"		
	31"	MC18x42.7	5
	36"		
PLATE GIRDER WEB	31"	W27x84	7
	36"		
	37"	W33x118	9
	42"		
	43"	W36x135	10
	48"		

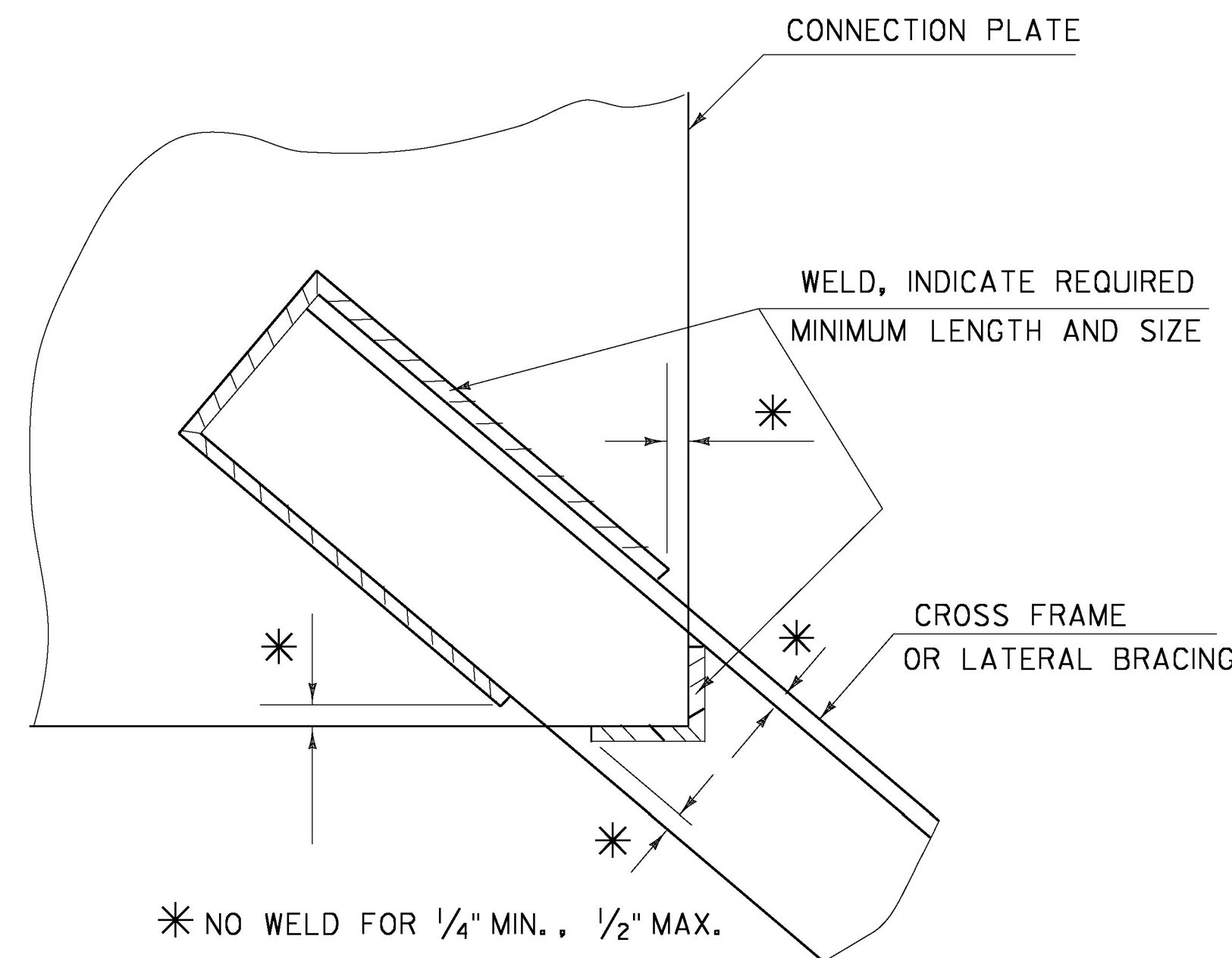

WELD LOCATION DETAIL AT CROSS
FRAMES AND LATERAL BRACING

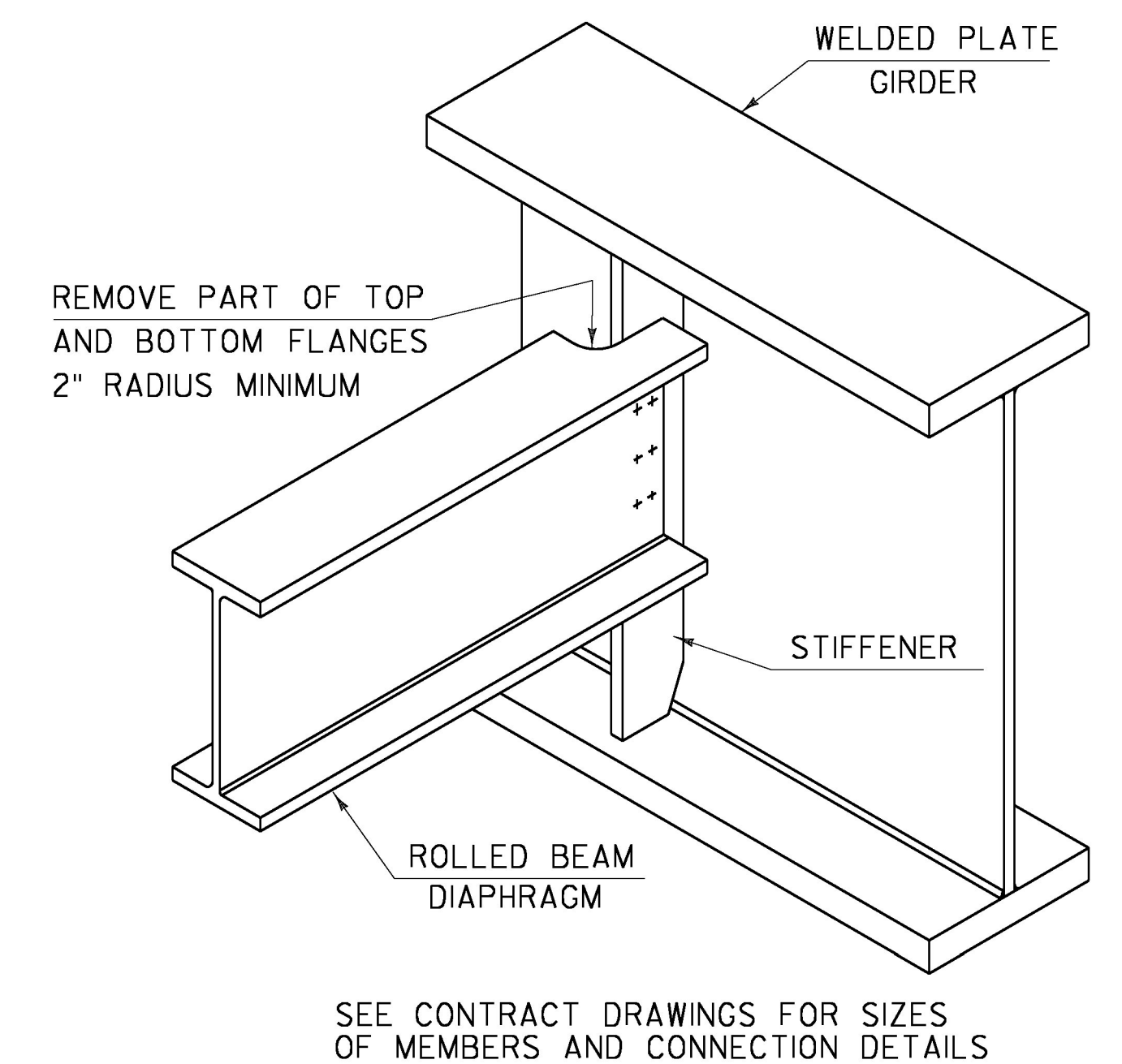

ROLLED BEAM USED AS DIAPHRAGM

DETAILS ON THIS SHEET ARE "NOT TO SCALE" UNLESS NOTED OTHERWISE.

REVISIONS	
MAY 7, 2010	APPROVED FOR USE BY VAOT STRUCTURES SECTION
MAY 2, 2011	ADD INTERMEDIATE DIAPHRAGMS DETAIL & ADD NOT TO SCALE NOTE

STRUCTURAL STEEL PLATE GIRDER DETAILS AND NOTES

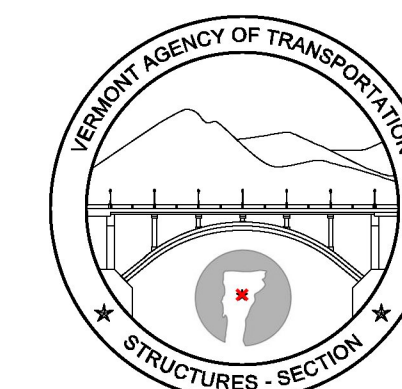

STRUCTURES
DETAIL
SD-602.00