

**SECTION RAIL POST DETAILS**  
SCALE: 1/2" = 1'-0"

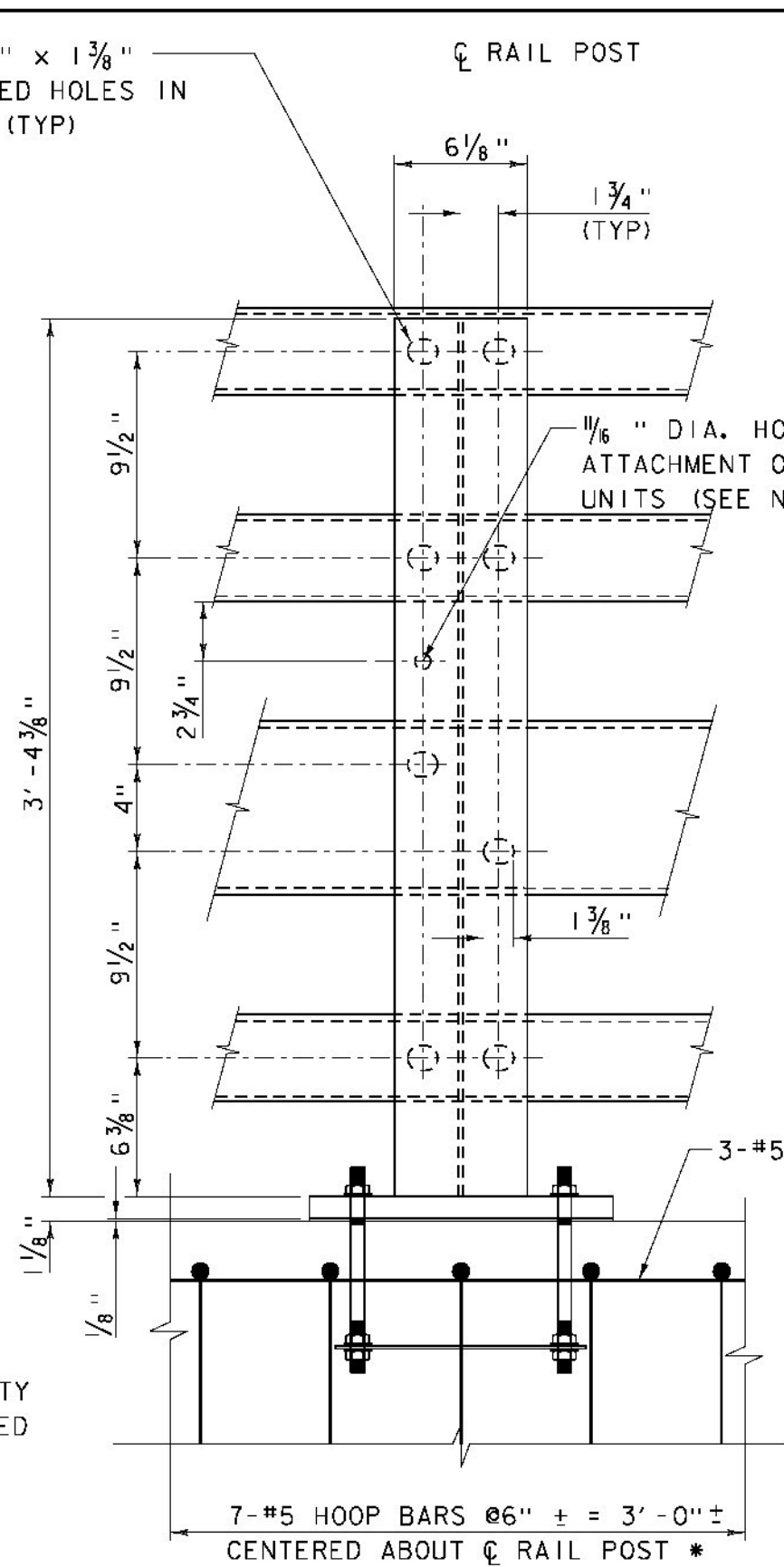

**BACK ELEVATION**

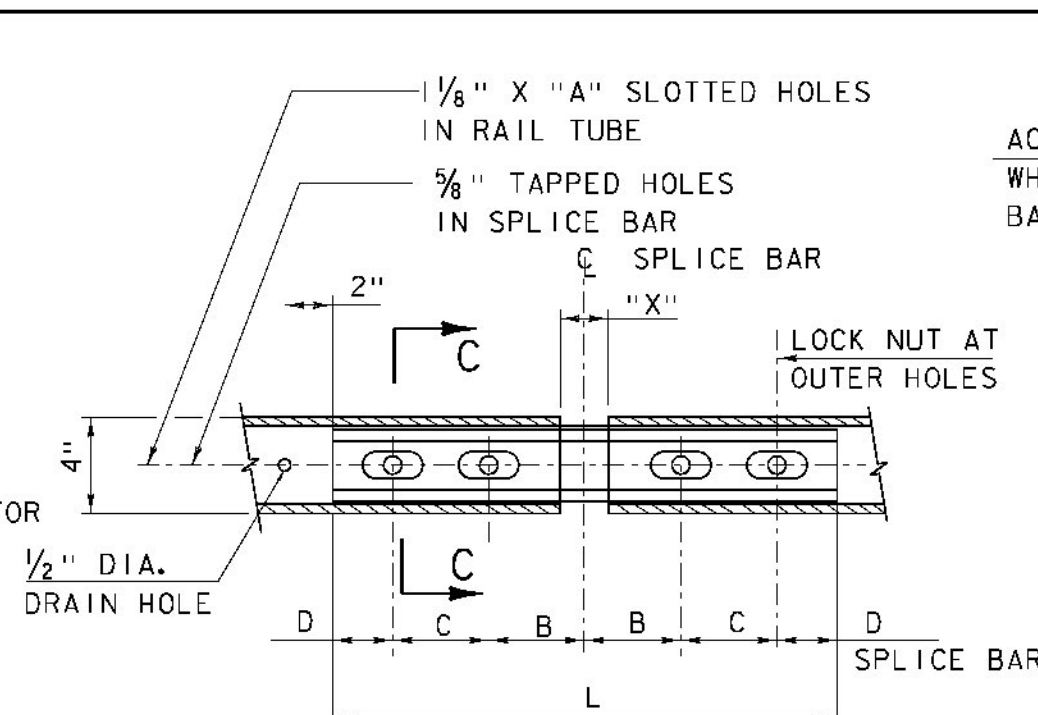

**RAIL SPLICE (BOTTOM VIEW)**  
SCALE: 1/2" = 1'-0"

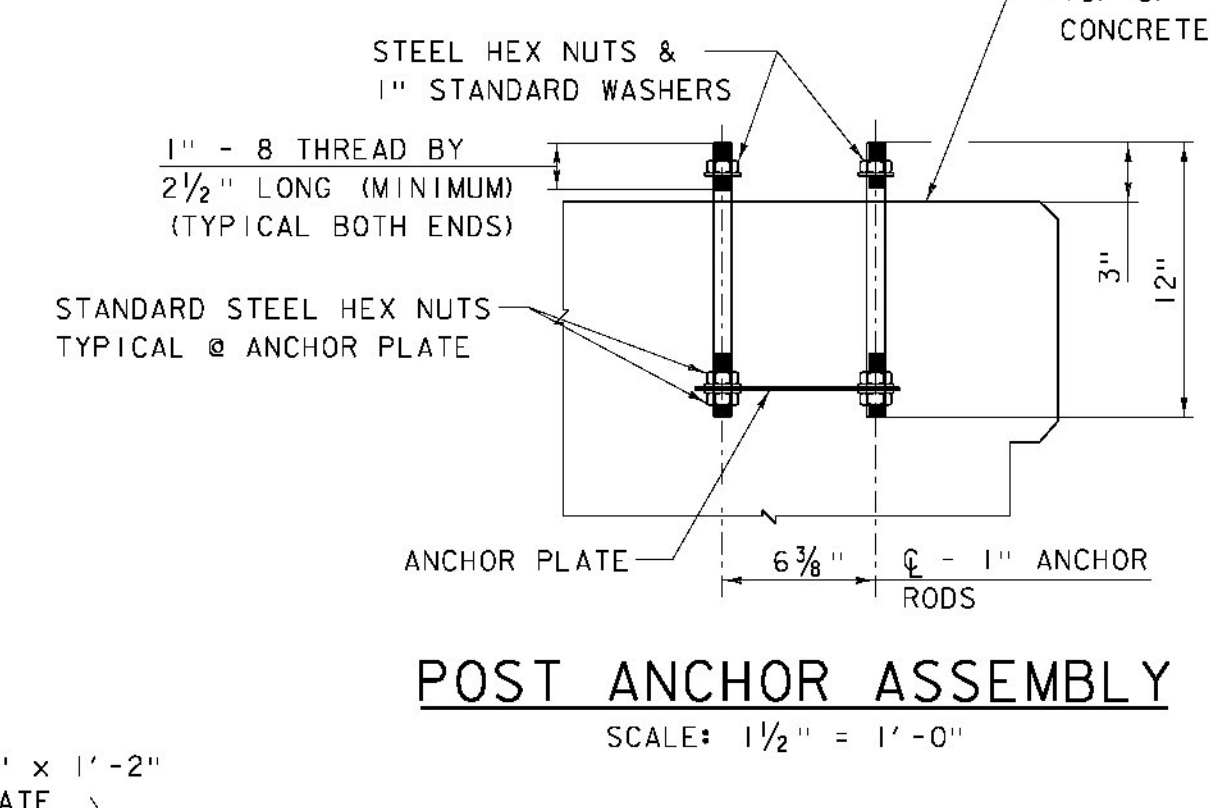

**POST ANCHOR ASSEMBLY**  
SCALE: 1/2" = 1'-0"

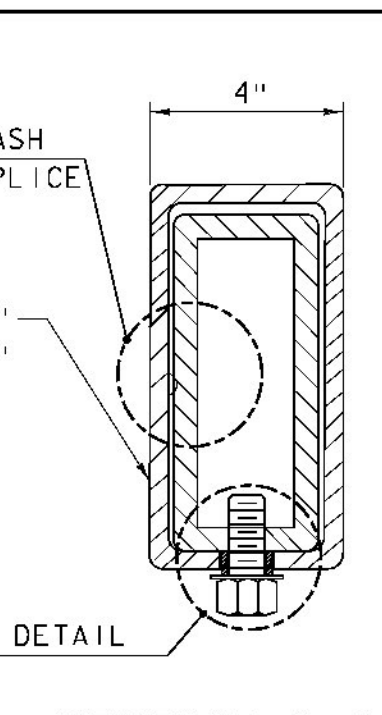

**SECTION C-C**

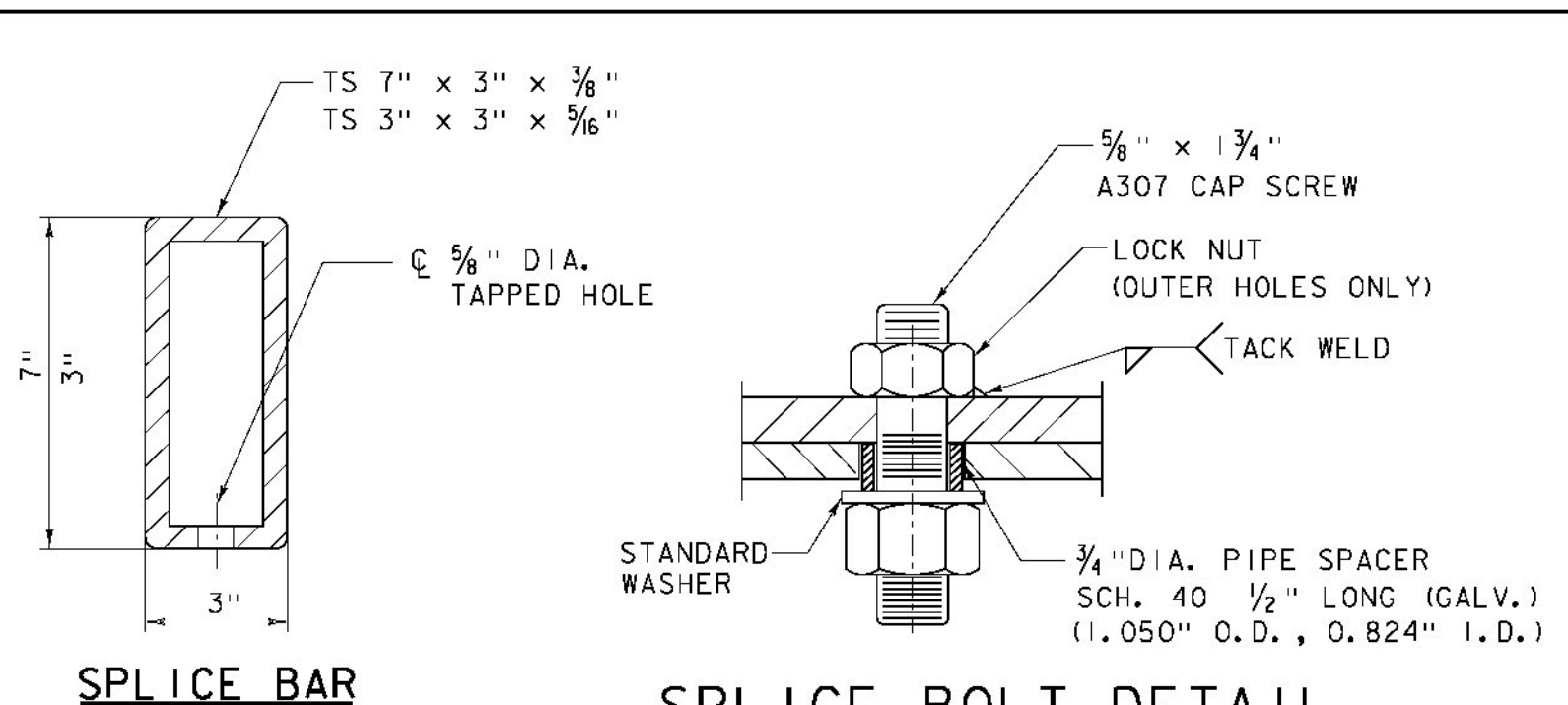

**SPLICE BAR SECTION**

**SPLICE BOLT DETAIL**  
SCALE: 6" = 1'-0"

**RAIL SPLICE DETAILS**  
SCALE: 3" = 1'-0"

**RAIL NOTES**

- ITEM 525.34, BRIDGE RAILING, GALVANIZED 4 RAIL BOX BEAM SHALL INCLUDE POSTS, BASE PLATES, ANCHOR PLATES, ANCHOR RODS, PREFORMED PADS, RAIL ASSEMBLY BOLTS, NUTS, WASHERS, STUDS, STRUCTURAL TUBING, SPLICE BARS, PIPE SPACERS, ALL APPURTENANCES, AND GALVANIZING.
- BRIDGE RAIL POSTS SHALL BE SET NORMAL (90 DEGREES) TO THE PROFILE GRADE, EXCEPT ON GRADES OVER 5% WHERE POSTS SHALL BE SET VERTICAL.
- ENDS OF RAIL TUBE SECTIONS SHALL BE SAWED OR MILLED AND SHALL BE TRUE AND SMOOTH. ALL CUT EDGES OF ALL MATERIAL SHALL BE GROUND SMOOTH.
- EACH PIECE OF RAIL TUBING SHALL BE ATTACHED TO A MINIMUM OF THREE (3) POSTS.
- BOLT HOLES SHALL BE DRILLED OR PUNCHED. FLAME CUTTING MAY BE USED TO FINISH SLOTTED HOLES IF MECHANICALLY GUIDED.
- AT INTERIOR SPLICES, PIPE SPACERS SHALL BE USED ON ONLY ONE SIDE OF THE SPLICE TO ALLOW MOVEMENT ON THAT SIDE. ALL RAILS IN A SPLICE SHALL RECEIVE THE SAME TREATMENT. AT END SPLICES PIPE SPACERS SHALL BE USED ON BOTH SIDES OF THE SPLICE TO ALLOW MOVEMENT ON EACH SIDE.
- MILL OR SHOP TRANSVERSE WELDS SHALL NOT BE PERMITTED ON ANY RAIL ELEMENT. RAIL ELEMENTS USED ON CURVES SHALL USE 3/8" WALL TUBES AND SHALL BE SHOP FORMED TO THE REQUIRED CURVATURE.
- NO PUNCHING, DRILLING, CUTTING OR WELDING SHALL BE PERMITTED AFTER GALVANIZING, EXCEPT AS ALLOWED IN DETAILS A AND B. DAMAGED AREAS OF GALVANIZING SHALL BE THOROUGHLY CLEANED, PRETREATED, AND PAINTED WITH TWO COATS OF ORGANIC ZINC-RICH GALVANIZING REPAIR PAINT, HAVING MIN. 94% ZINC BY WEIGHT, TO A THICKNESS EQUAL TO THE ORIGINAL COATING ACCORDING TO THE STANDARD SPECIFICATIONS AND ASTM A780.
- NUTS FOR 1" DIA. THREADED ANCHOR RODS CONNECTING THE BASE PLATE TO THE CONCRETE SHALL BE TIGHTENED TO A SNUG FIT AND GIVEN AN ADDITIONAL 1/2 TURN.
- THREADS FOR ANCHOR RODS MAY BE ROLLED OR CUT. IF CUT THREADS ARE USED, BOLT DIAMETER SHALL NOT BE LESS THAN NOMINAL DIAMETER. IF ROLLED THREADS ARE USED, ROD DIAMETER SHALL NOT BE LESS THAN ROOT DIAMETER OF THREADS.

**MATERIAL NOTES**

- IN ACCORDANCE WITH SECTION 525 AND THE FOLLOWING:
- STRUCTURAL TUBING SHALL CONFORM TO THE REQUIREMENTS OF SUBSECTION 714.11 (ASTM A500, GRADE B, STRUCTURAL STEEL TUBING.) RAIL TUBING SHALL MEET THE LONGITUDINAL CHARPY V-NOTCH REQUIREMENTS OF 15 FT. LBS. AT 0° F. FOR ASTM A500, GRADE B, THE TEST SAMPLES SHALL BE TAKEN AFTER FORMING THE TUBES. CHARPY V-NOTCH IS NOT REQUIRED FOR SPLICE TUBES.
  - RAIL POSTS AND BASE PLATES SHALL CONFORM TO THE REQUIREMENTS OF ASTM A572 GR 50, EXCEPT ANCHOR PLATES MAY BE ASTM A36. SEE SUBSECTION 732.03.
  - THREADED STUDS AND MATCHING NUTS FOR RAIL-TO-POST ATTACHMENT (DETAIL A) SHALL CONFORM TO ASTM A276 TYPE 304, STAINLESS STEEL, AND SHALL BE TORQUE TESTED PER AWS D1.5, 7.7.1. DETAIL B BOLTS SHALL BE ASTM A325 OR A449. ALL OTHER BOLTS AND NUTS SHALL CONFORM TO ASTM A307 AND ASTM 563 GRADE A RESPECTIVELY OR BETTER, EXCEPT THAT ASTM A307 NUTS MAY BE USED ON THE BOTTOM OF ANCHOR ASSEMBLY. WASHERS SHALL BE HARDENED STEEL COMMERCIAL TYPE A PLAIN WIDE WASHERS AND SHALL MEET THE DIMENSIONAL REQUIREMENTS OF A.N.S.I. B18.22. ANCHOR RODS SHALL CONFORM TO ASTM A449 (SEE SUBSECTION 714.07).
  - IN ACCORDANCE WITH SUBSECTION 726.08 ALL STEEL COMPONENTS (EXCEPT STAINLESS) SHALL BE GALVANIZED AFTER FABRICATION IN CONFORMANCE TO AASHTO M232 (ASTM A153) AND AASHTO M111 (ASTM A123). THE GALVANIZING KETTLE SHALL HAVE 0.05 TO 0.09 PERCENT NICKEL. GALVANIZED SURFACES SHALL HAVE A UNIFORM APPEARANCE AND GALVANIZED MATERIAL SHALL BE PROPERLY STORED.
  - DETAIL A STUDS SHALL BE WELDED ON AFTER TUBES ARE GALVANIZED BY SPOT GRINDING OFF GALVANIZING, WELDING ON STUDS, THEN TOUCH UP GALVANIZING PER NOTE #8 ABOVE.
  - PREFORMED BEARING PADS (1/8" THICK) SHALL CONFORM TO AASHTO M251.
  - SEE STANDARD DRAWING G-1 FOR DETAILS OF DELINEATORS. A DELINEATOR SHALL BE INSTALLED AT 30 FOOT SPACING OR THE NEAREST POST. WHITE IS TO BE INSTALLED ON THE DRIVERS RIGHT. PAYMENT SHALL BE INCIDENTAL TO OTHER ITEMS.

3/4" DIA. x 1 3/4" A304 STAINLESS STEEL THREADED STUDS WELDED TO RAIL (TYP) & S.S. NUT & WASHER (SEE NOTES 13 AND 15)

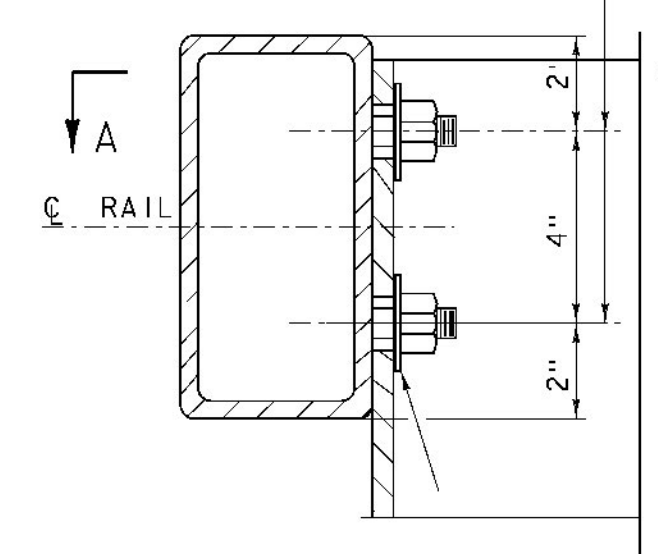

**DETAIL A**  
SCALE: 3" = 1'-0"

3/4" DIA. ROUND HEAD BOLTS & NUTS (ASTM A325) (SEE DETAIL)

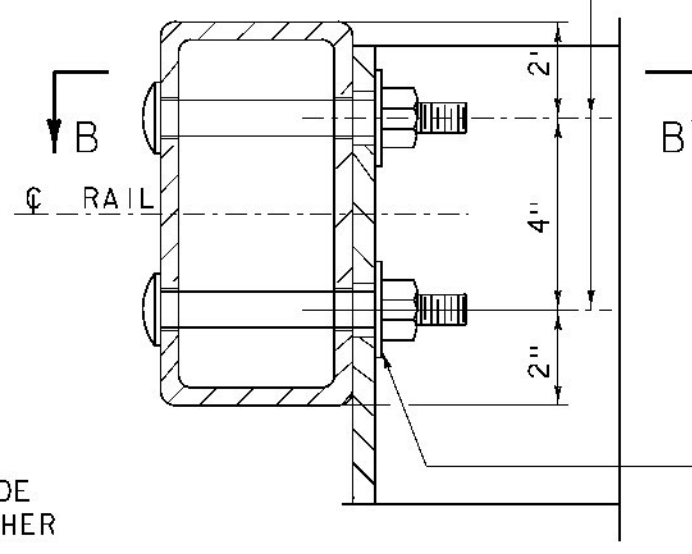

**DETAIL B**  
SCALE: 3" = 1'-0"

TYPE A WIDE PLAIN WASHER (NOMINAL 3/8" I.D., 2" O.D., 1/2" THICK)

TYPE A WIDE PLAIN WASHER (NOMINAL 3/8" I.D., 2" O.D., 1/2" THICK)

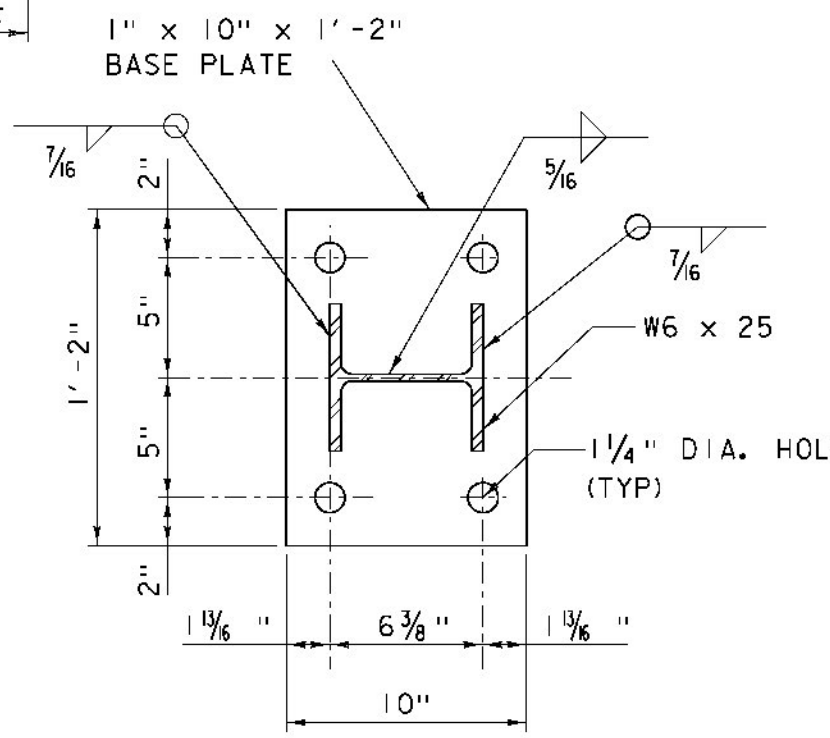

**POST BASE PLATE**  
SCALE: 1/2" = 1'-0"

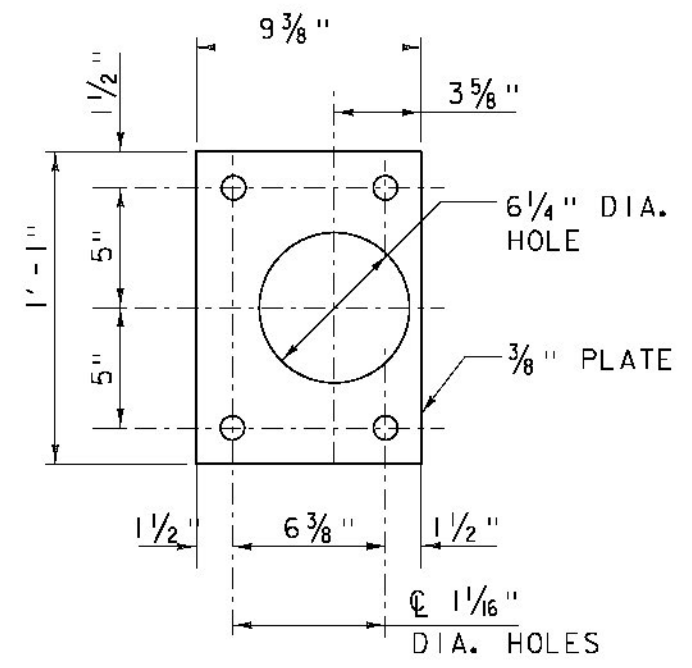

**ANCHOR PLATE**  
SCALE: 1/2" = 1'-0"

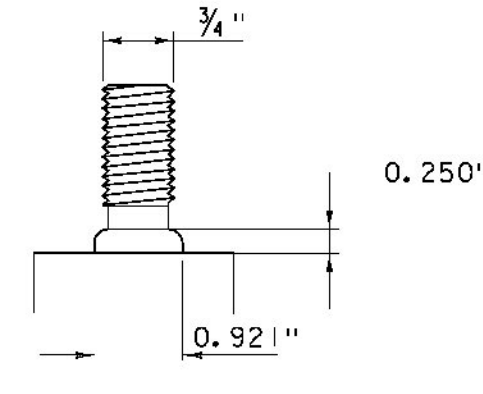

**STUD WELD DETAIL**  
SCALE: 6" = 1'-0"

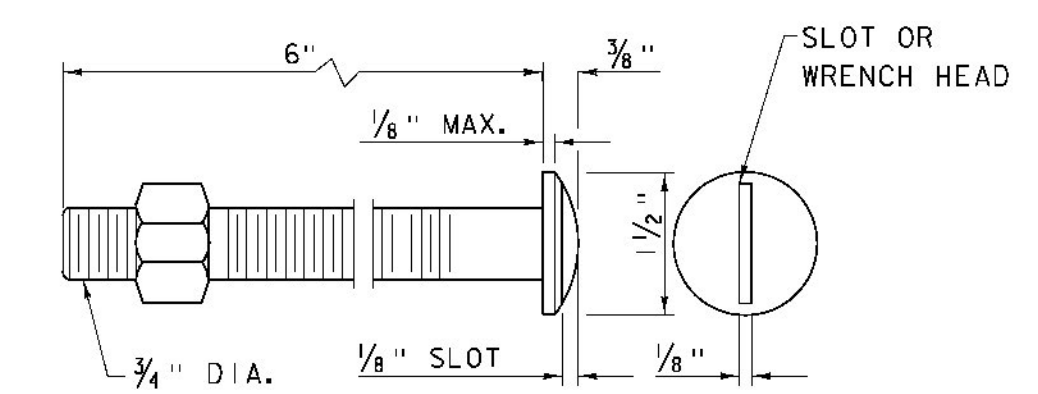

**A325 ROUND HEAD BOLT DETAIL**  
SCALE: 6" = 1'-0"

SPLICE BAR DIMENSION TABLE						
T	A	B	C	D	X	L
INTERIOR	2 1/2"	4"	4"	2"	3/4"	1'-8"
≤ 3/4"	2 1/2"	4"	4"	2"	2"	1'-8"
3/4" < T < 5/4"	3 1/2"	5"	5"	2 1/2"	3"	2'-1"

T = TOTAL MOVEMENT OF BRIDGE  
\* = END SPLICE BAR

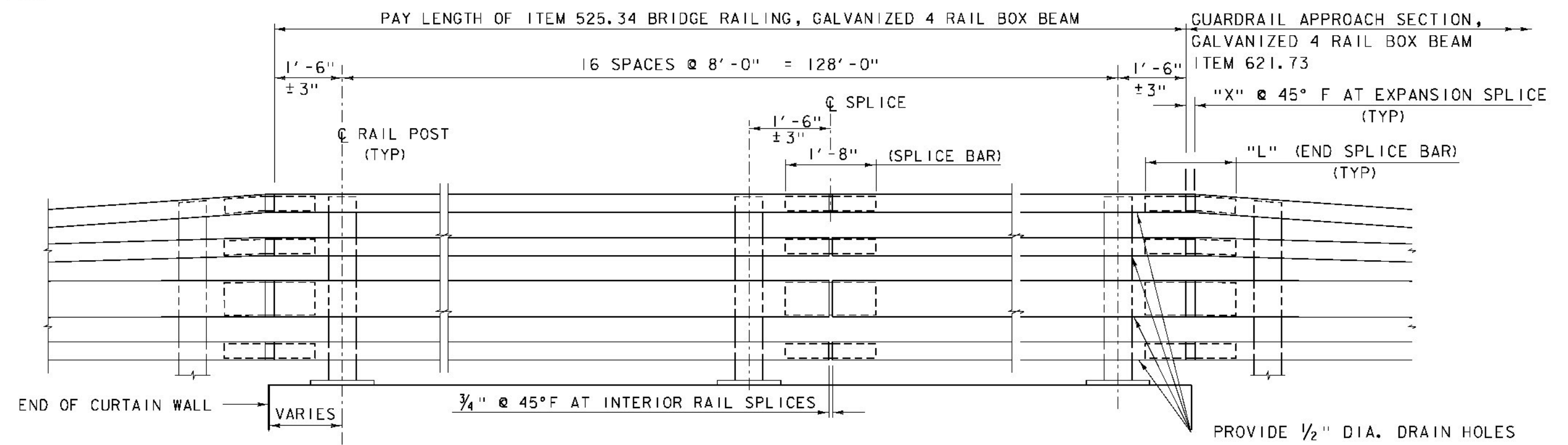

**RAIL ELEVATION**  
SCALE: 1/2" = 1'-0"

PROJECT NAME: LINCOLN  
PROJECT NUMBER: BRF 0188 (8)  
FILE NAME: z10j066T4rail.dgn  
PLOT DATE: 8-DEC-2014  
PROJECT LEADER:  
DESIGNED BY:  
4 RAIL BOX BEAM BRIDGE RAIL  
DRAWN BY:  
CHECKED BY:  
SHEET 58 OF 62