

ROUTE MARKER ASSEMBLY FRAMES

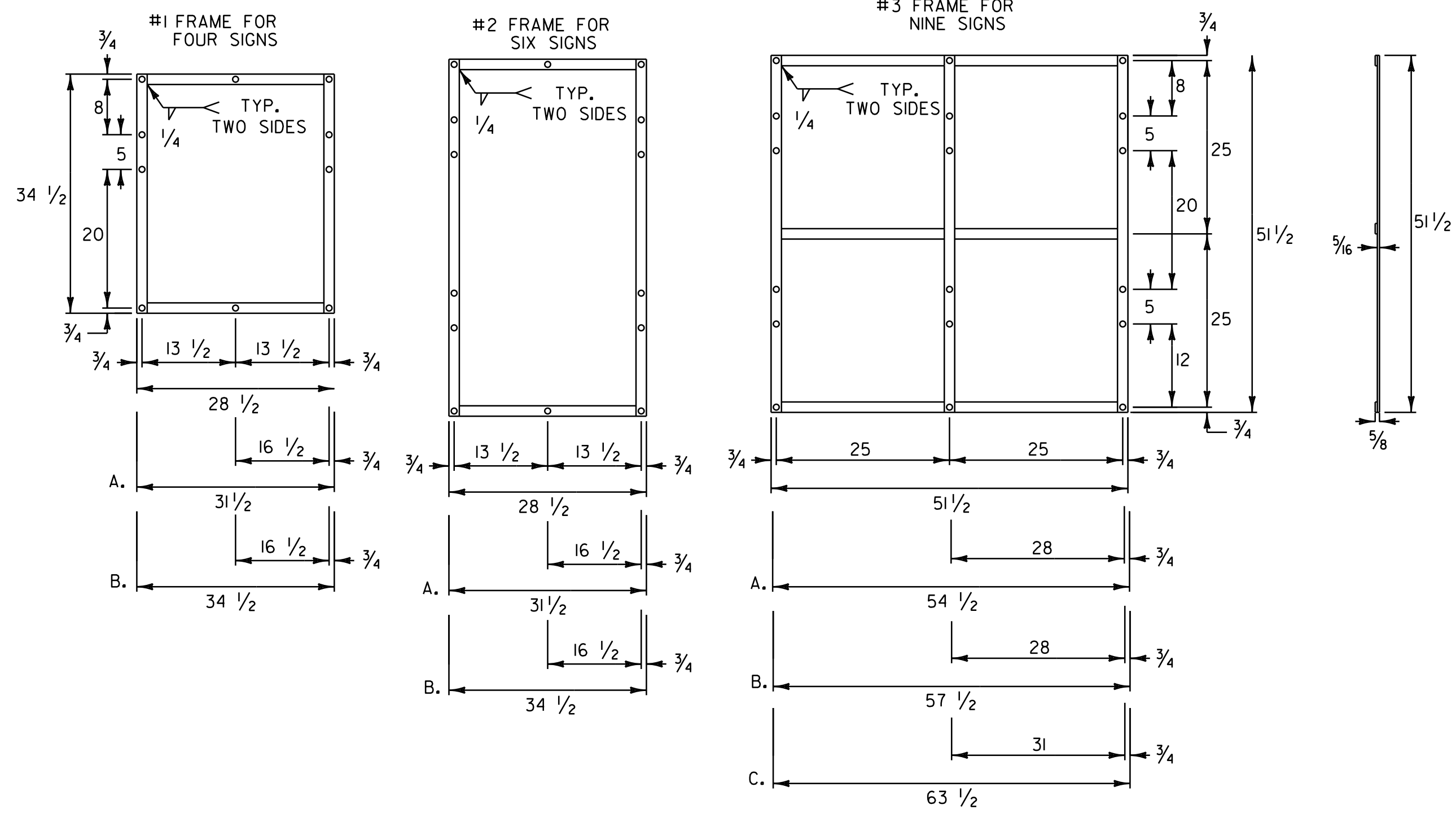

NOTES:

- NOTES FOR 1 AND 2 FRAME:
 - WITH ONE 30 INCH THREE DIGIT SIGN IN AN OUTSIDE POSITION.
 - WITH TWO 30 INCH THREE DIGIT SIGNS
- NOTES FOR 3 FRAME:
 - WITH ONE 30 INCH THREE DIGIT SIGN IN THE CENTER POSITION OR TWO SUCH SIGNS IN THE OUTSIDE POSITIONS.
 - WITH THREE 30 INCH THREE DIGIT SIGNS.
- ALL HOLES SHALL BE 7/16 INCH DIAMETER. FOR OTHER SIGN COMBINATIONS THAN ABOVE, THE FRAME DIMENSIONS AND HOLE SPACING SHALL BE MODIFIED AS NECESSARY. THE FRAME SHALL BE PAINTED WITH ONE COAT OF PRIMER AND A SECOND COAT OF BLACK PAINT. THE PAINT SHALL BE OF THE TYPE USED ON EXTERIOR METAL SURFACES TO PREVENT METAL CORROSION.
- STANDARD FRAMES SHALL BE 5/16 INCH x 1 1/2 INCH WELDED A-36 STEEL.

STANDARD MOUNTING OF ROUTE MARKER ASSEMBLIES

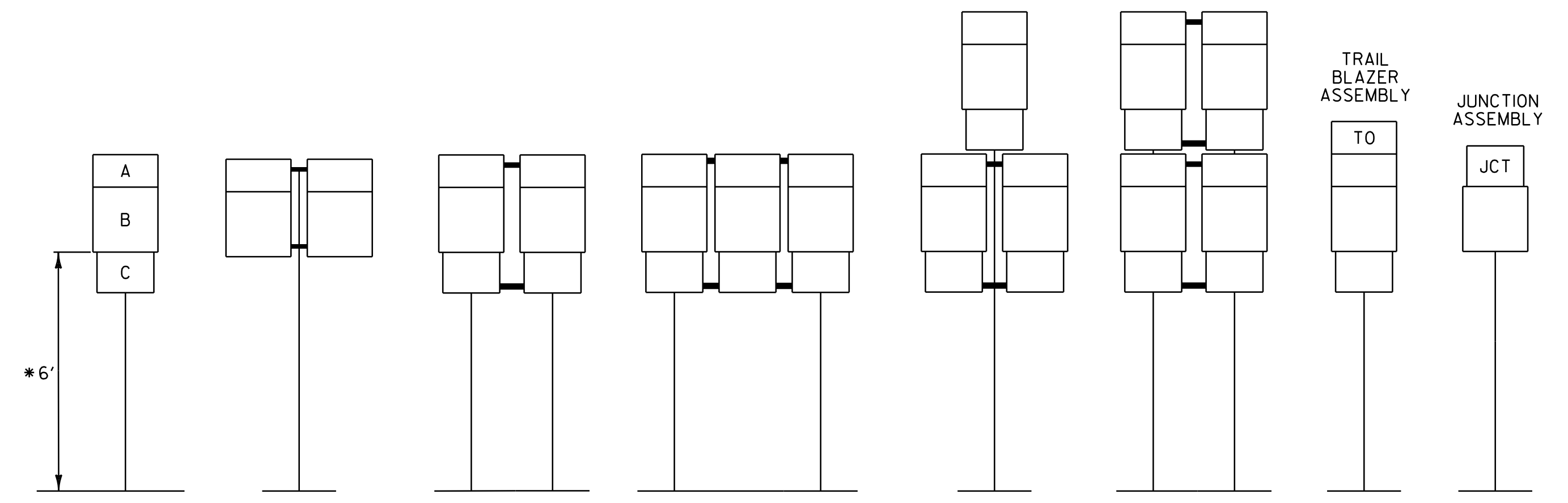

INSTALLATION SEQUENCE:

IN MULTIPLE HORIZONTAL MOUNTINGS PLACE A ROUTE MARKER ASSEMBLY INDICATING A LEFT TURN ON THE LEFT SIDE OF THE ASSEMBLY; RIGHT TURN ON THE RIGHT SIDE. FOR VERTICALLY STACKED MOUNTINGS PLACE THE STRAIGHT THROUGH MOVE INDICATION ON TOP, THE LEFT OR RIGHT TURNS AS APPROPRIATE BENEATH.

NOTES:

- ALL DIMENSIONS SHOWN IN INCHES UNLESS OTHERWISE NOTED.
- VERTICAL FRAME MEMBERS SHALL LINE UP WITH SIGN POST ON WHICH THEY ARE MOUNTED.

- A - CARDINAL DIRECTION MARKER
 B - ROUTE NUMBER
 C - ADVANCE TURN ARROW OR DIRECTIONAL ARROW

* WHERE PARKING OR PEDESTRIAN TRAFFIC WILL OCCUR IN THE IMMEDIATE VICINITY OF THESE SIGNS MINIMUM VERTICAL CLEARANCE SHALL BE INCREASED TO SEVEN FEET.

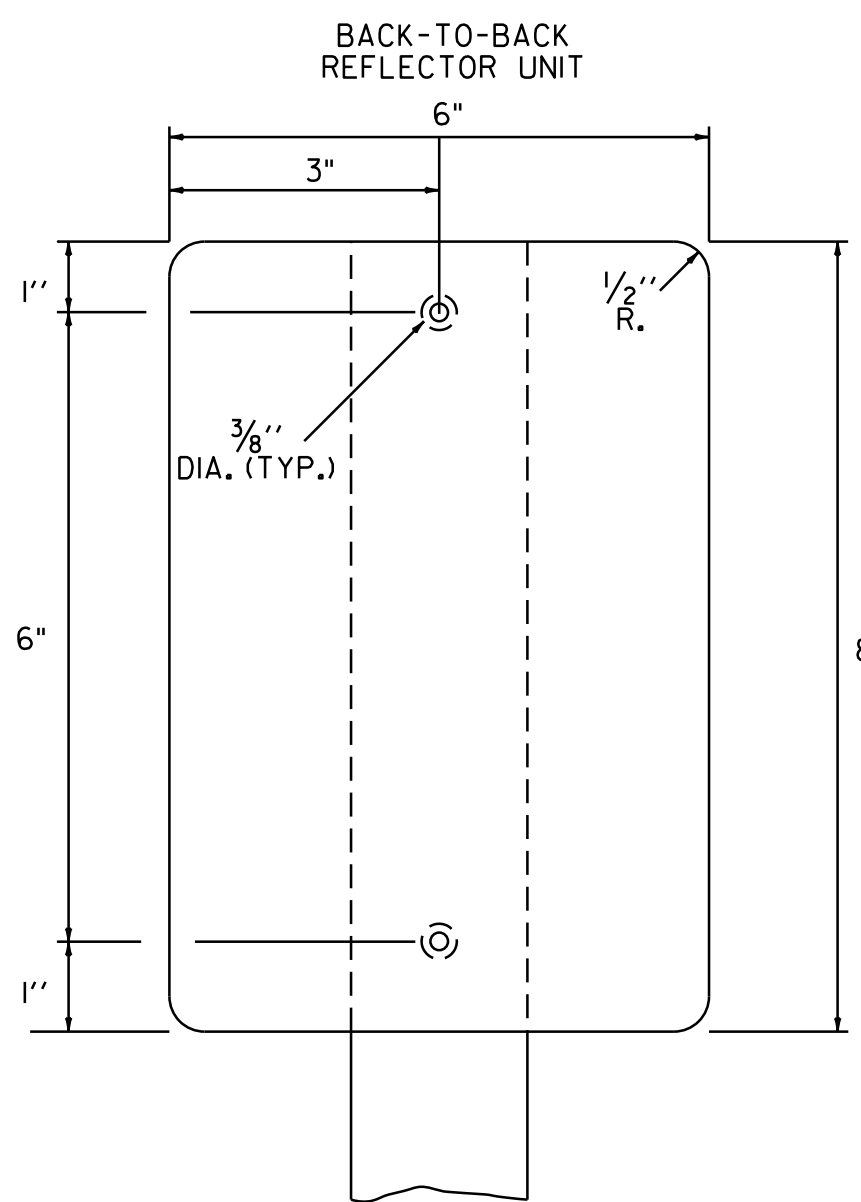

TYPE II (6"X8")

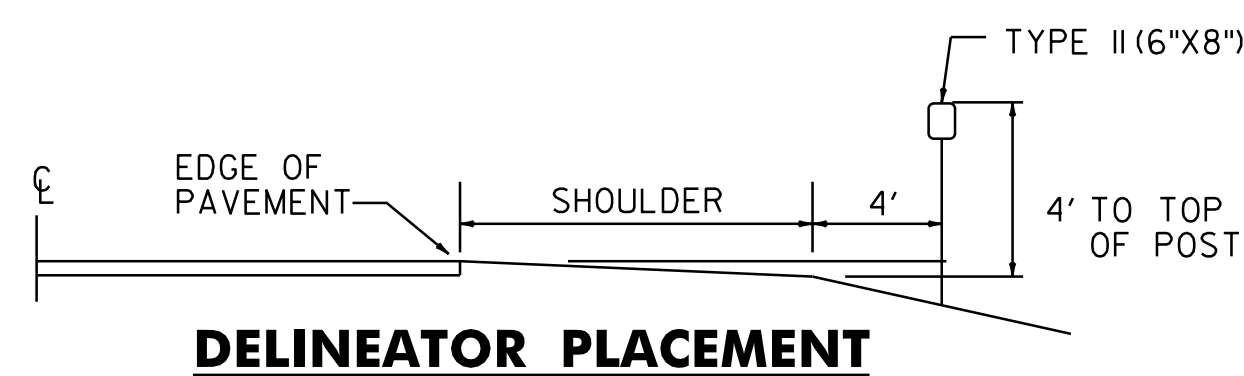

DELINEATOR PLACEMENT

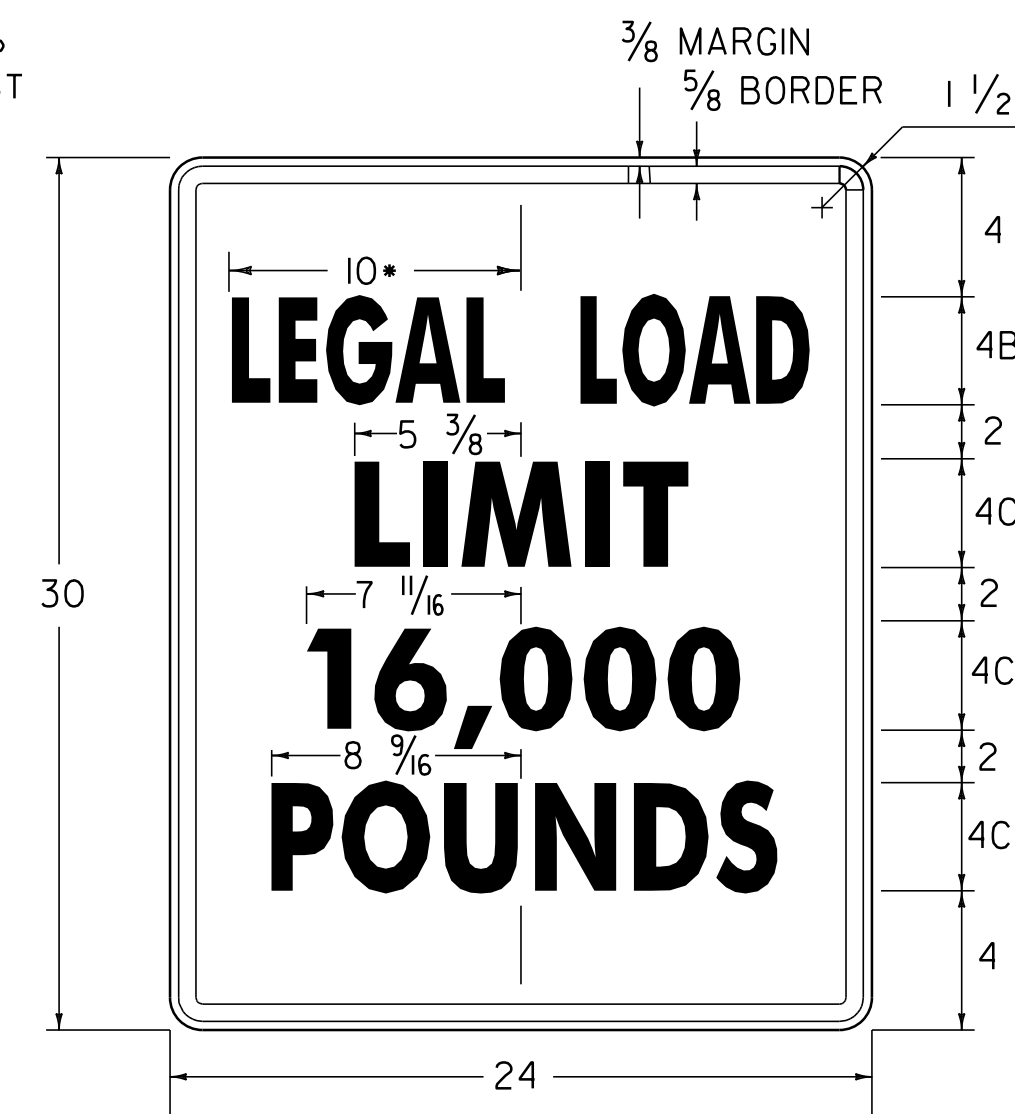

* REDUCE SPACING 50 %
 LINE 3 ALTERNATE - 16,000

VR-017

1.500" RADIUS, 0.625" BORDER, 0.375" INDENT
 COLORS: LEGEND - BLACK
 BACKGROUND - WHITE
 TEXT STYLE: "LEGAL LOAD" B; "LIMIT" C;
 "16,000" C; "POUNDS" C

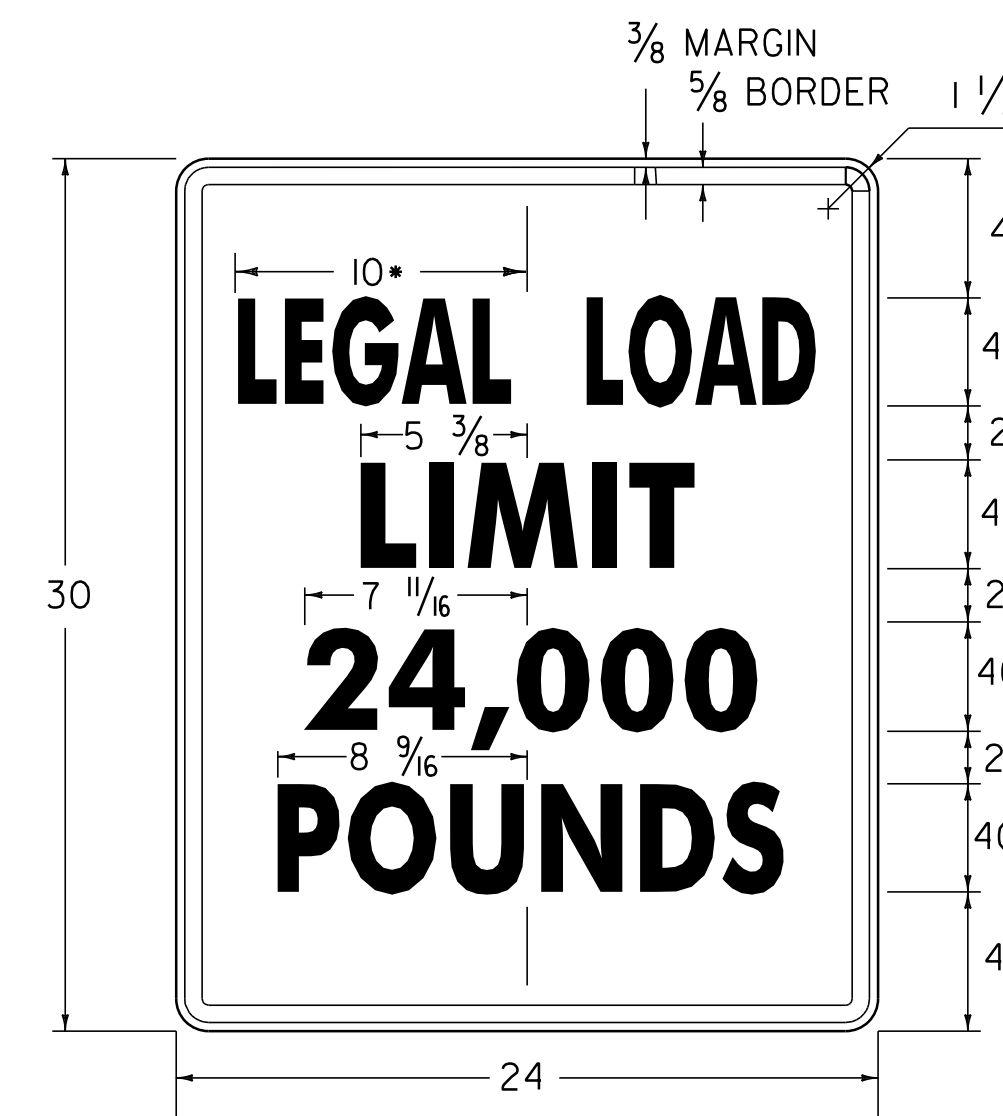

* REDUCE SPACING 50 %
 LINE 3 ALTERNATE - 16,000

VR-017

1.500" RADIUS, 0.625" BORDER, 0.375" INDENT
 COLORS: LEGEND - BLACK
 BACKGROUND - WHITE
 TEXT STYLE: "LEGAL LOAD" B; "LIMIT" C;
 "24,000" C; "POUNDS" C

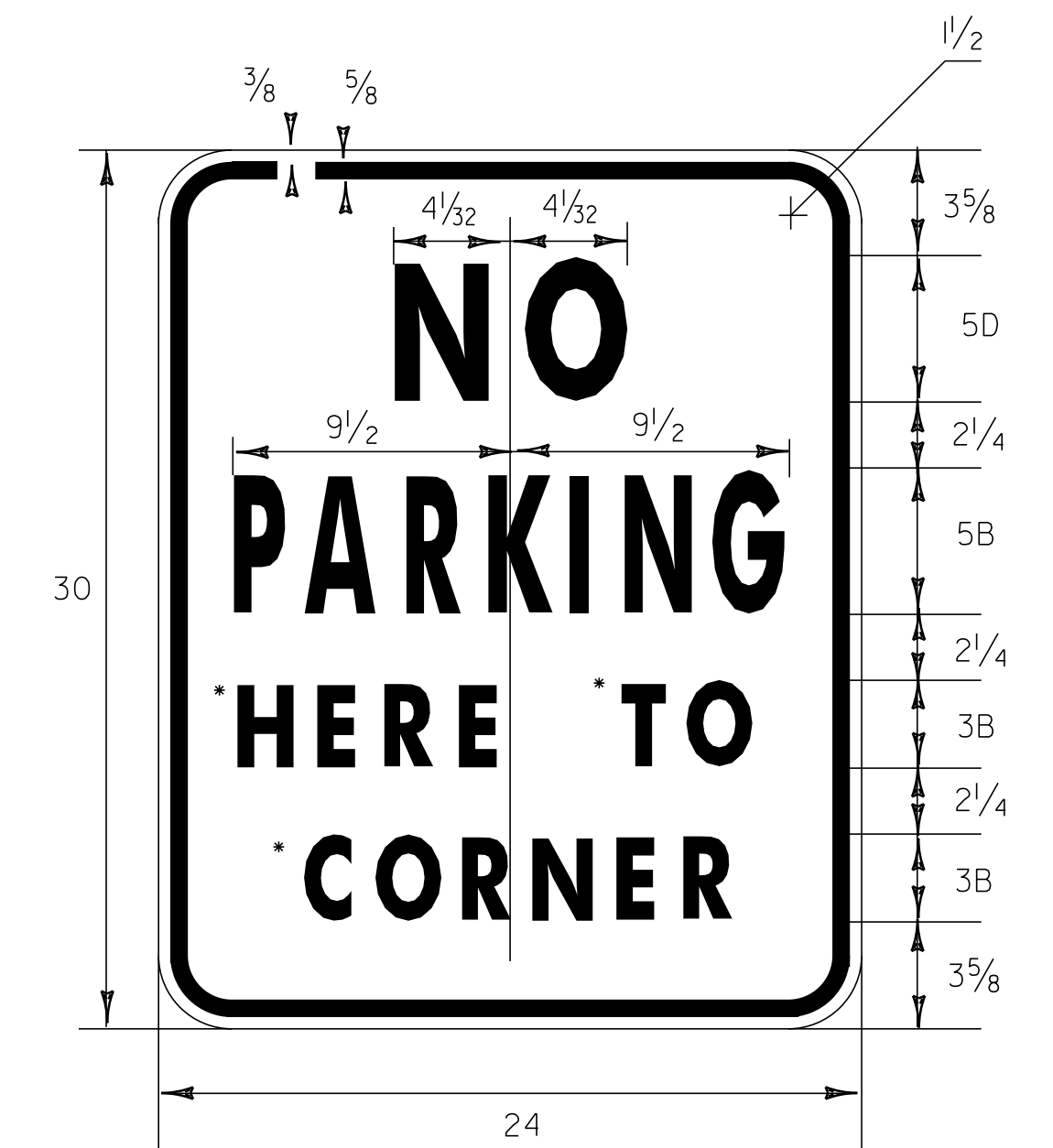

VR-345

* OPTICALLY CENTER (HERE, TO, CORNER)
 1.500" RADIUS, 0.625" BORDER, 0.375" INDENT
 COLORS: LEGEND - RED
 BACKGROUND - WHITE
 TEXT STYLE: "NO" D; "PARKING" B; "HERE TO" B;
 "CORNER" B

ALL DIMENSIONS SHOWN IN INCHES UNLESS OTHERWISE NOTED.

PROJECT NAME: STATEWIDE NORTHWEST REGION
 PROJECT NUMBER: STP HRRR(5)

FILE NAME: I0K018_wrk.dgn PLOT DATE: 14-SEP-2012 15:28
 PROJECT LEADER: JLS DRAWN BY: NLA
 DESIGNED BY: NLA CHECKED BY: JLS
 GENERAL SIGN DETAILS 2 SHEET 7 OF 51