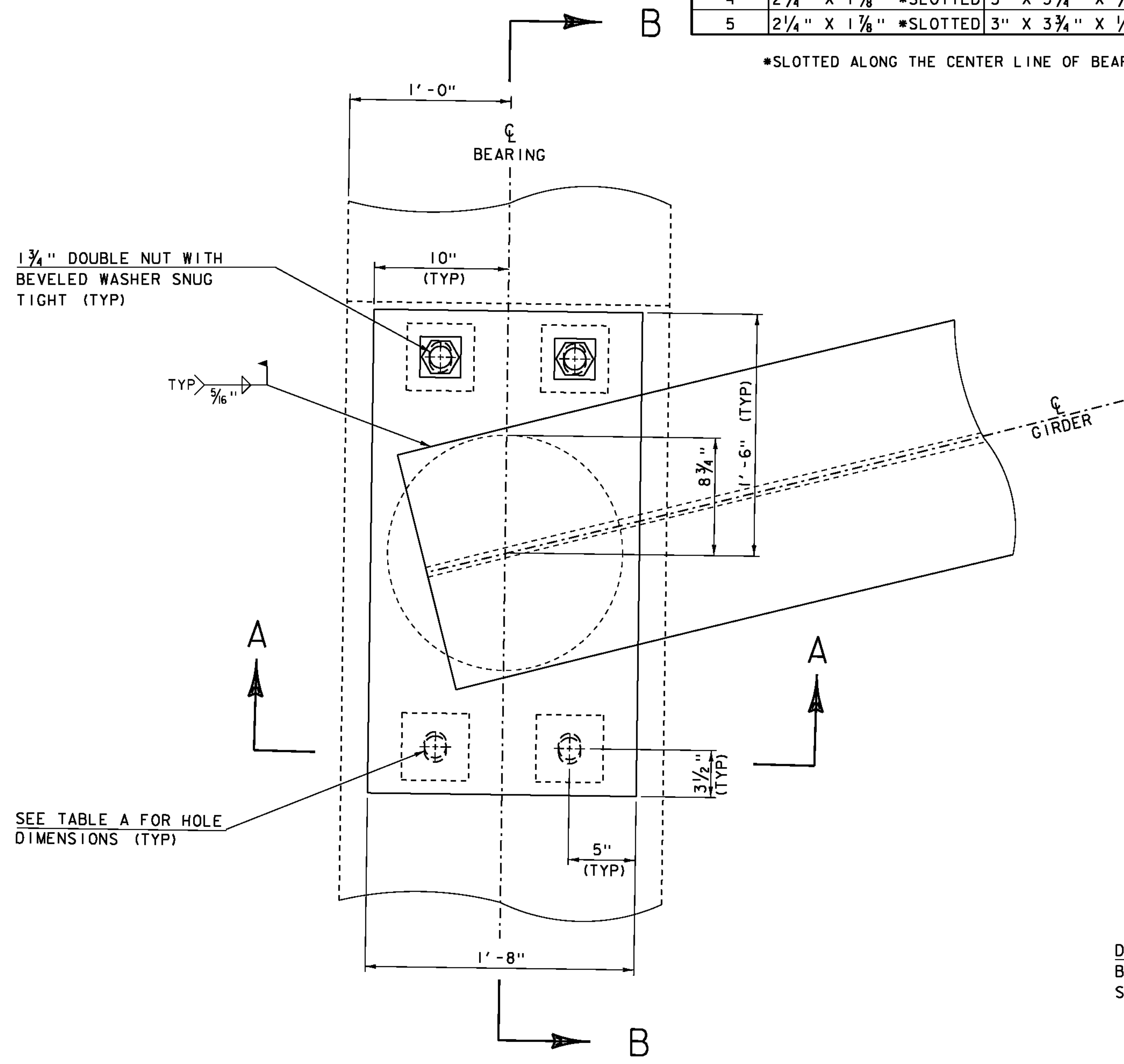

TABLE A		
GIRDER	HOLE DIMENSIONS	BEVELED WASHER
1	2 1/4" X 1 7/8" *SLOTTED	3" X 3 3/4" X 1/2" *SLOTTED
2	1 7/8"	3" X 3" X 1/2"
3	1 7/8"	3" X 3" X 1/2"
4	2 1/4" X 1 7/8" *SLOTTED	3" X 3 3/4" X 1/2" *SLOTTED
5	2 1/4" X 1 7/8" *SLOTTED	3" X 3 3/4" X 1/2" *SLOTTED

\*SLOTTED ALONG THE CENTER LINE OF BEARING



PLAN VIEW

GIRDER 1 SHOWN, OTHERS SIMILAR

1 3/4" DOUBLE NUT WITH BEVELED WASHER SNUG TIGHT (TYP)

TYP > 5/16"

SEE TABLE A FOR HOLE DIMENSIONS (TYP)

ABUTMENT 1  
FIXED BEARING DETAILS  
NOT TO SCALE

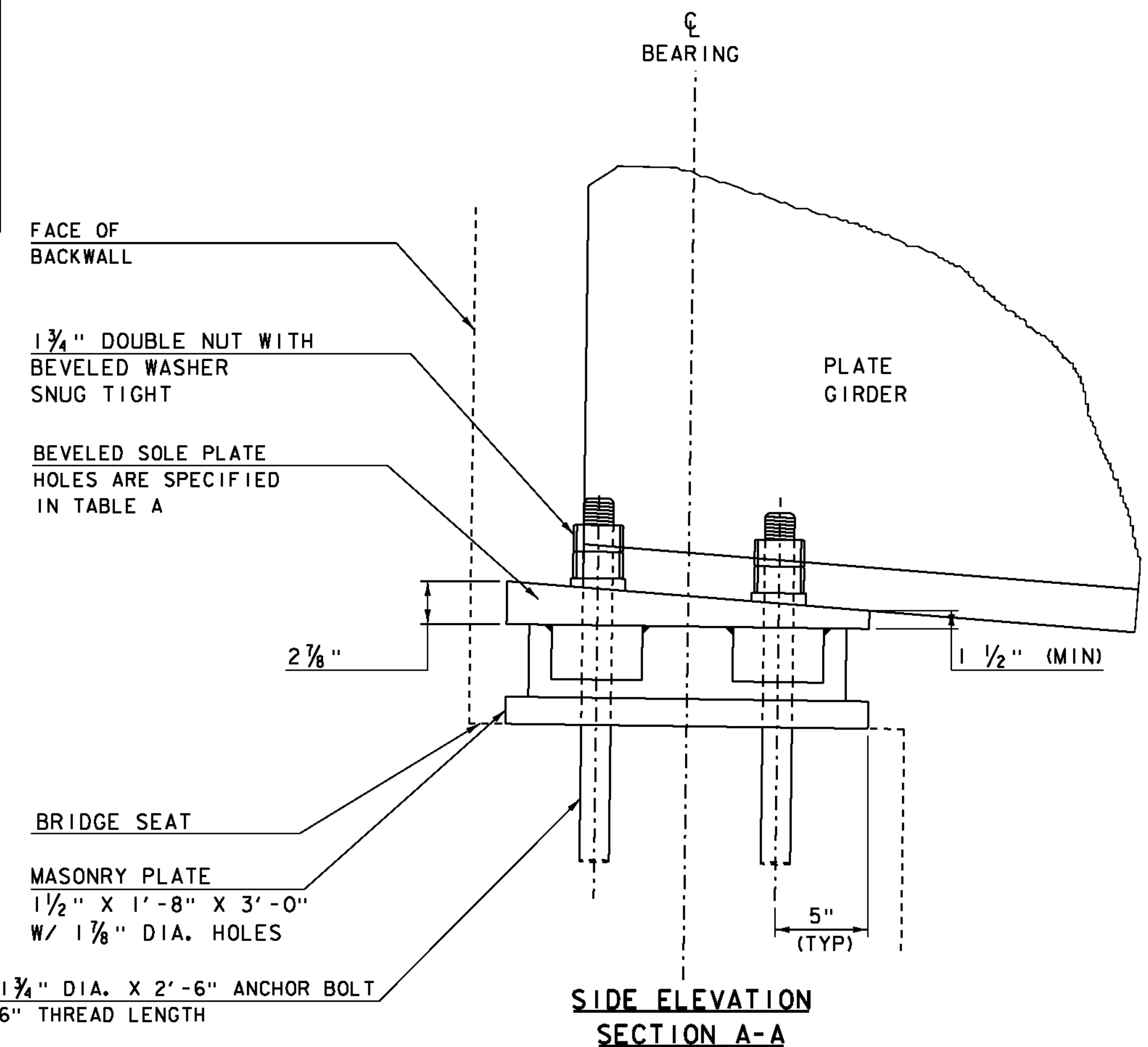

SIDE ELEVATION  
SECTION A-A

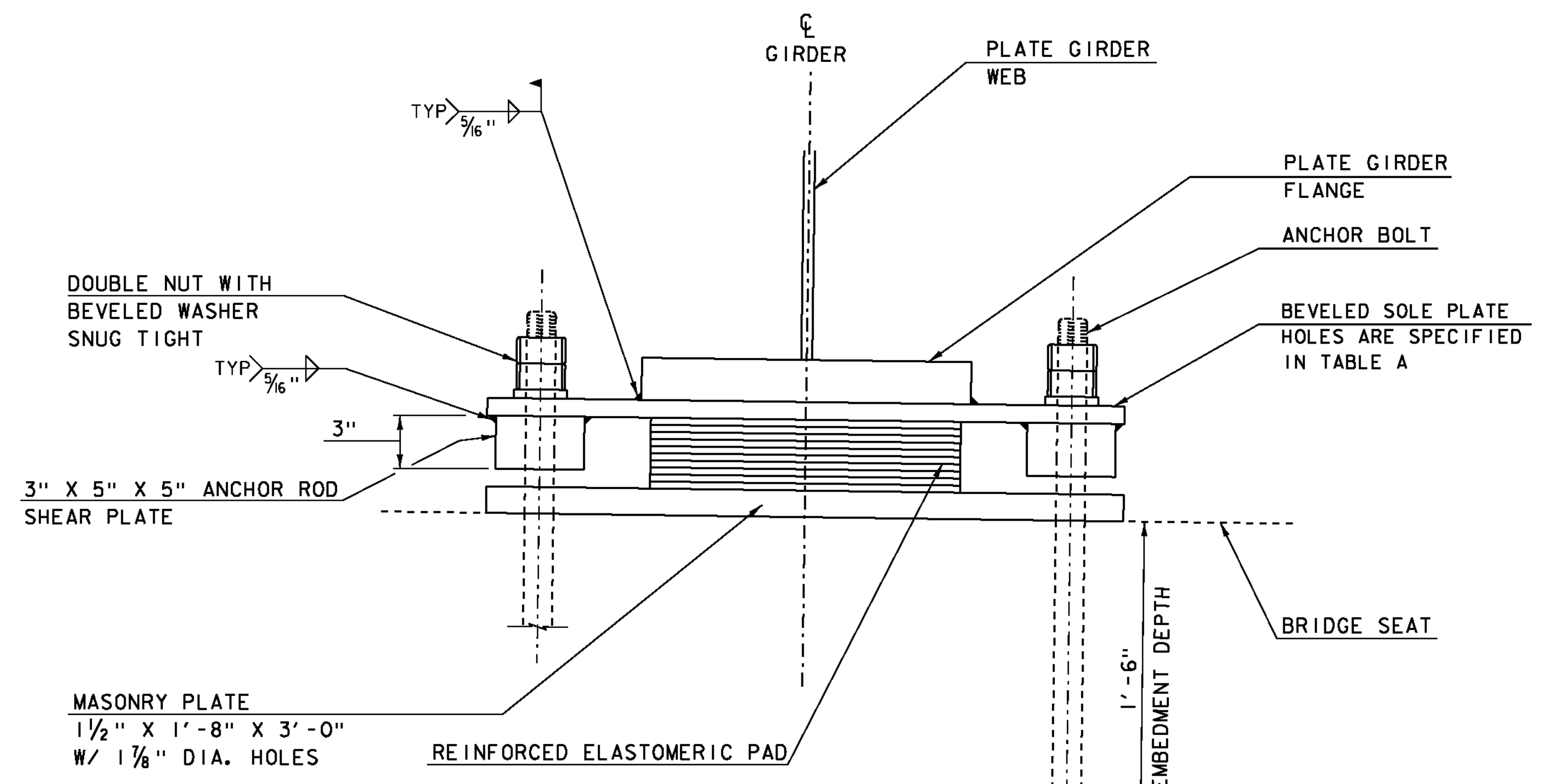

END ELEVATION  
SECTION B-B

NOTE:  
THE BOTTOM FLANGE SHALL BE WELDED TO THE SOLE PLATE A MIN OF 6" ON THE SIDES ONLY

PROJECT NAME: BARRE TOWN	PLOT DATE: 27-SEP-2012
PROJECT NUMBER: BRF 6100(7)	DRAWN BY: R. PELLETT
FILE NAME: s06j002sup.dgn	CHECKED BY: J. GRIFFIN
PROJECT LEADER: J. LACROIX	SHEET 41 OF 70
DESIGNED BY: J. LACROIX	
FIXED BEARING DETAILS	