

GUARDRAIL DEFLECTION CHART (PER AASHTO - ROADSIDE DESIGN GUIDE - LATEST EDITION)		
TYPE	GR POST SPACING	DEFLECTION
THREE CABLE W/STEEL POSTS	16' - 0"	11' - 6"
W/WOODEN POSTS	12' - 6"	11' - 6"
W-BEAM W/STRONG POST	6' - 3"	3'
BOX BEAM	6' - 0"	5'
THRIE BEAM W/STRONG POST	6' - 3"	2'

THIS CHART LISTS THE THEORETICAL MAXIMUM DEFLECTION DISTANCE, UPON IMPACT, OF DIFFERENT TYPES OF GUARDRAIL AND VARIOUS POST SPACINGS.

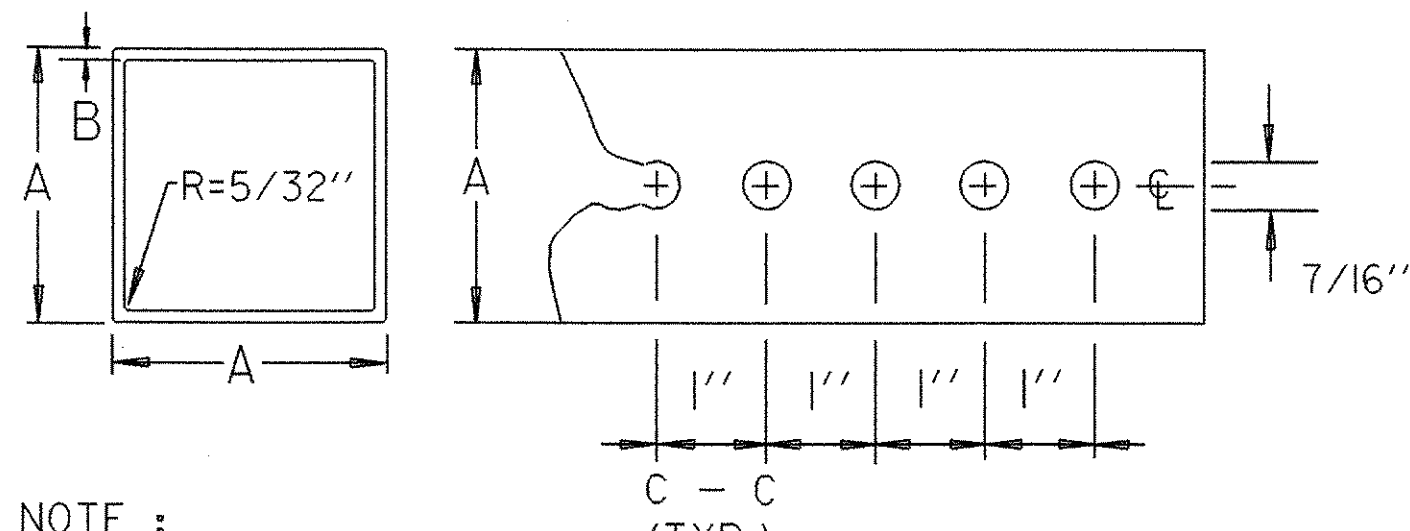

NOTE :

THE POSTS SHALL BE CAREFULLY FORMED OF STEEL WITH A MINIMUM YIELD OF 55,000 PSI, INTO A SIZE AND SHAPE WITH CORNERS INDUCTION WELDED IN SUCH A MANNER THAT NEITHER FLASH NOR WELD SHALL INTERFERE WITH THE TELESCOPING PROPERTIES, NOR DAMAGE THE GALVANIZING.

* THE WALL THICKNESS TOLERANCES SHALL BE +.005" AND -.010" FOR THE 12 GAUGE.

* THE WALL THICKNESS TOLERANCES SHALL BE +.002" AND -.008" FOR THE 14 GAUGE.

DIMENSION DETAILS AND POST SELECTION CHART

POST SELECTION CHART								
SIGN AREA (FT ²) X H (FT) ≤ SV (SELECTION VALUE)								
POST SIZE	DIMENSIONS			SECTION MODULUS	ONE POST S _v	TWO POST S _v	THREE POST S _v	NUMBER PERMITTED IN 8' PATH
LBS/FT.	A	*B	GAUGE	IN ³				
1.88	1-3/4"	.083	14	0.230	46	92	138	TWO
2.42	2"	.083	12	0.380	77	154	231	TWO
3.35	2-1/2"	.105	12	0.642	130	260	390	ONE

DESIGN CRITERIA:

WIND SPEED = 70 MPH (10 -YEAR MEAN RECURRENCE INTERVAL)
WIND PRESSURE = 19 PSF
STEEL MINIMUM YIELD = 55,000 PSI
ALLOWABLE STRESS = (1.4) 0.60 FY

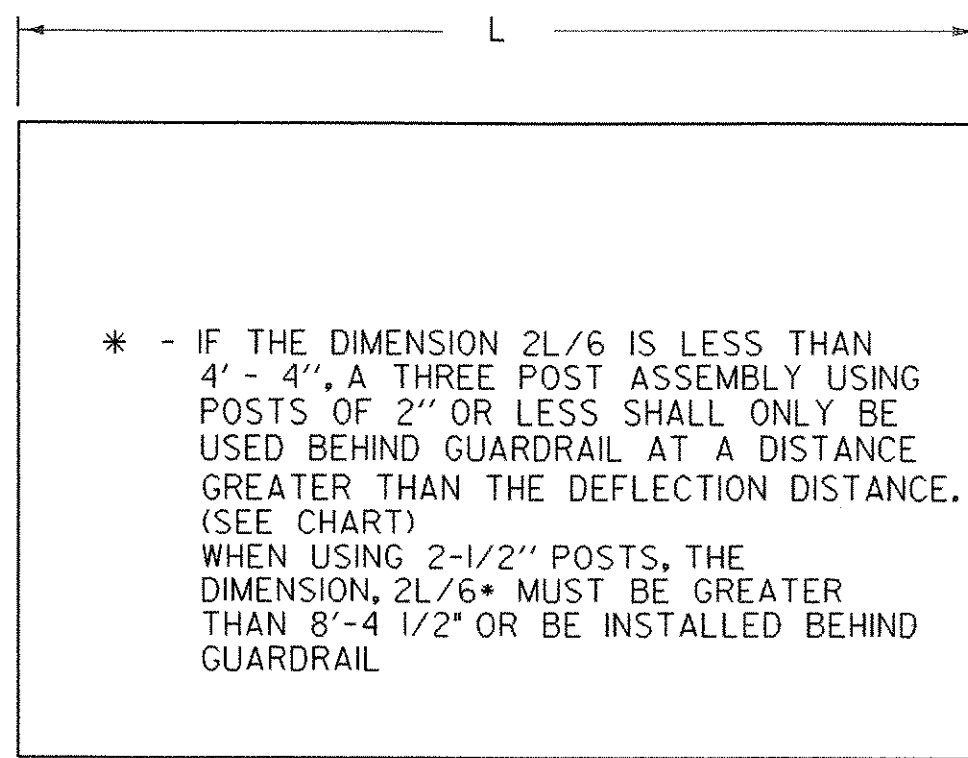

MULTI-POST INSTALLATIONS

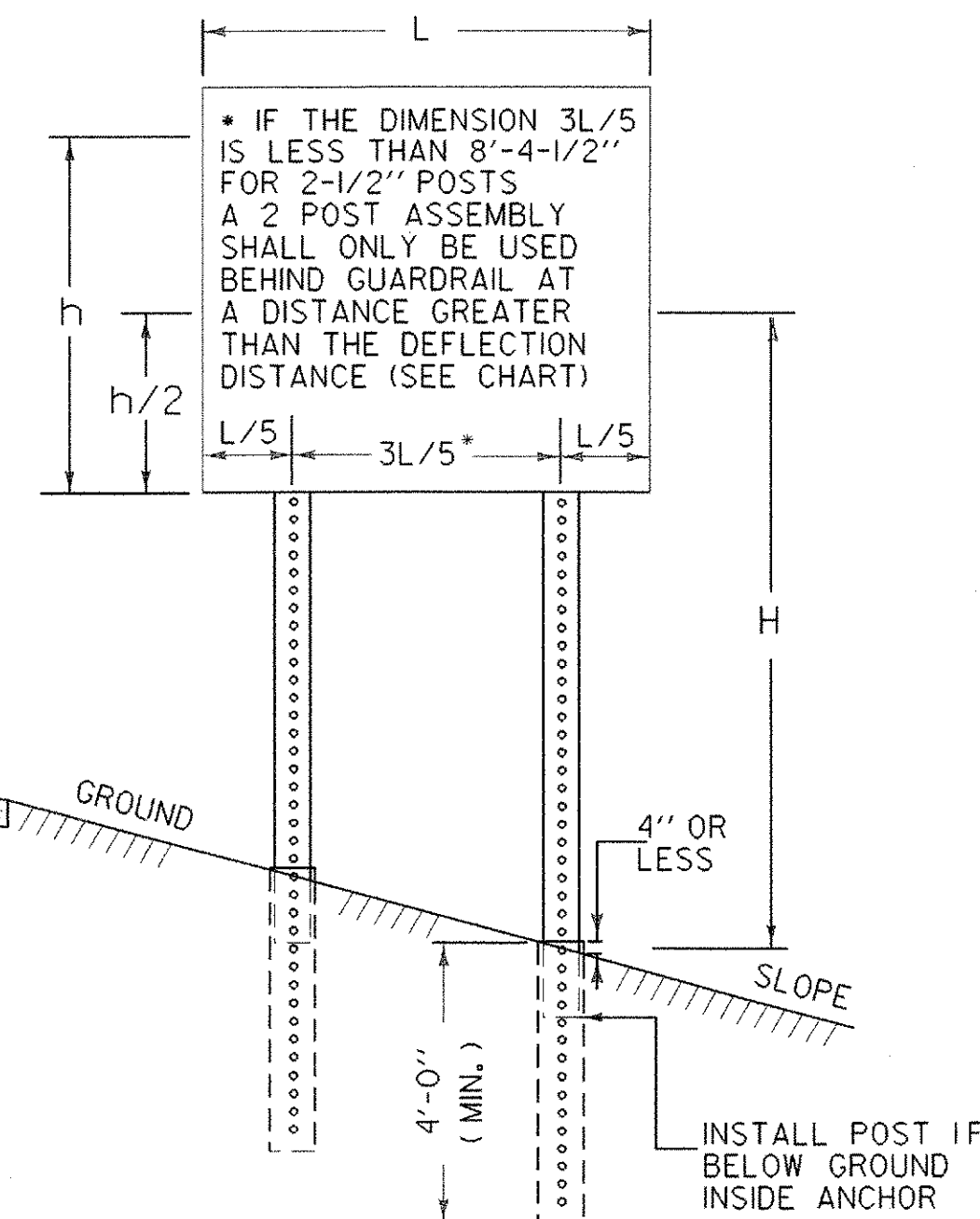

POST SPACING DETAILS

GENERAL NOTES

CONSTRUCTION METHODS - POSTS MAY BE DRIVEN OR SET IN A DUG HOLE AND BACKFILLED. IF DRIVEN, A DRIVING CAP SHALL BE USED. THE DUG HOLE INSTALLATION SHALL BE USED IN AREAS OF POOR SOIL CONDITIONS OR AS DIRECTED BY THE RESIDENT ENGINEER. BACKFILL SHALL BE COMPACTED AS DIRECTED BY THE RESIDENT ENGINEER.

SIGN CLEARANCES - HORIZONTAL AND VERTICAL SIGN CLEARANCES SHALL BE SHOWN ON THE PLANS OR THE APPROPRIATE STD. SHEETS.

SINGLE POST INSTALLATIONS SHALL BE LIMITED TO A SIGN AREA OF 20 SQ. FT. OR LESS

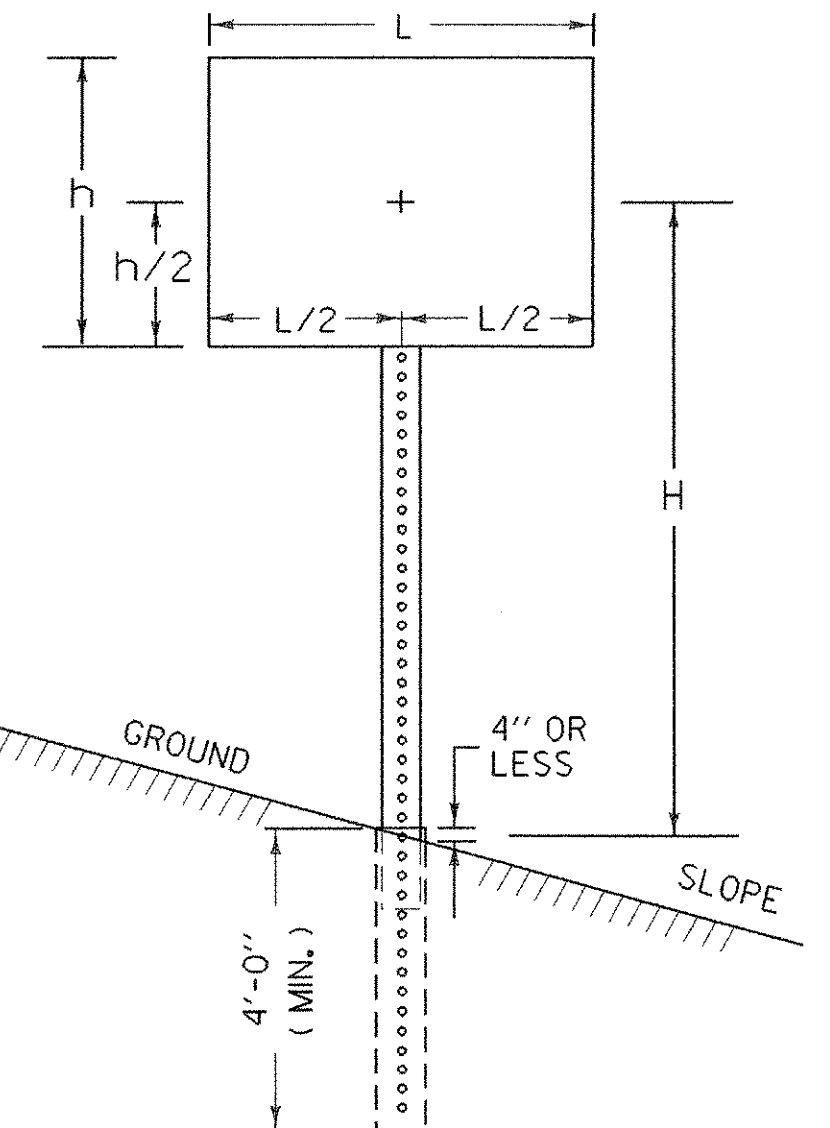

NOTE

WHEN USING SQUARE STEEL POSTS ON STEEP SLOPES (1 ON 2 OR STEEPER) ADD ONE FOOT EMBEDMENT FOR GREATER STABILITY.

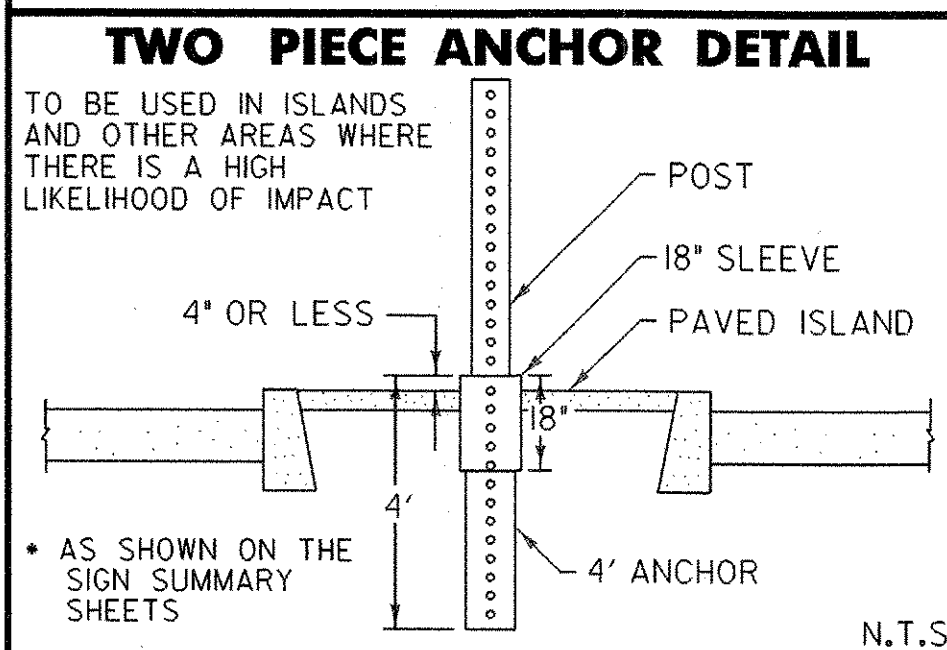

TOP VIEW OF ANCHOR, POST AND BOLT

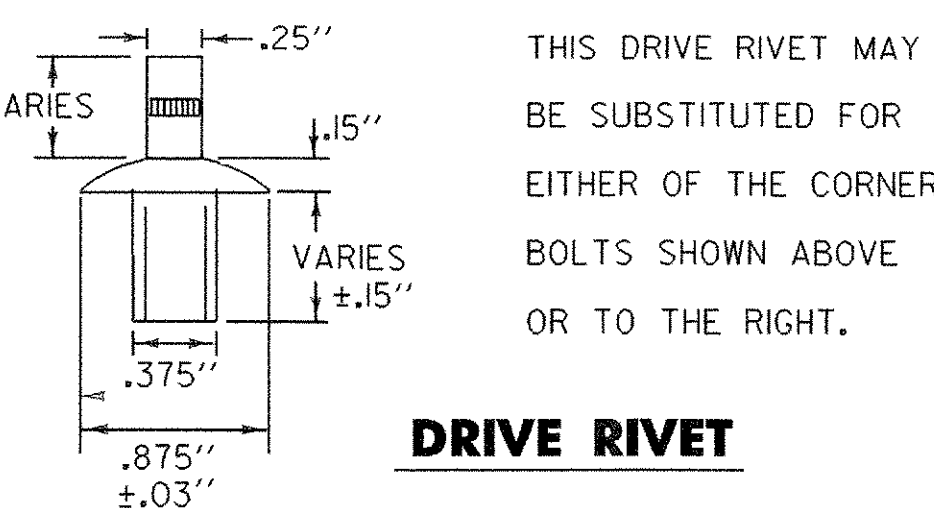
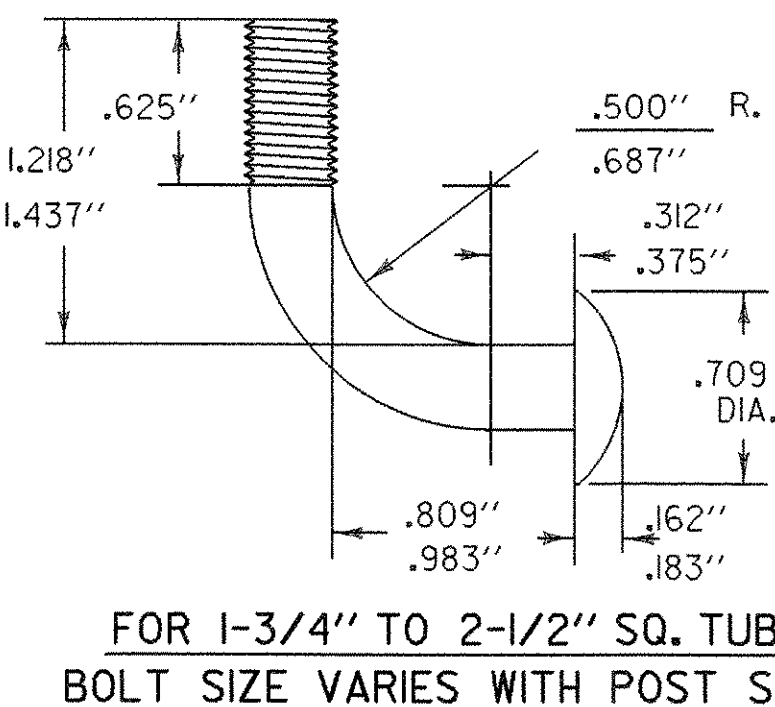
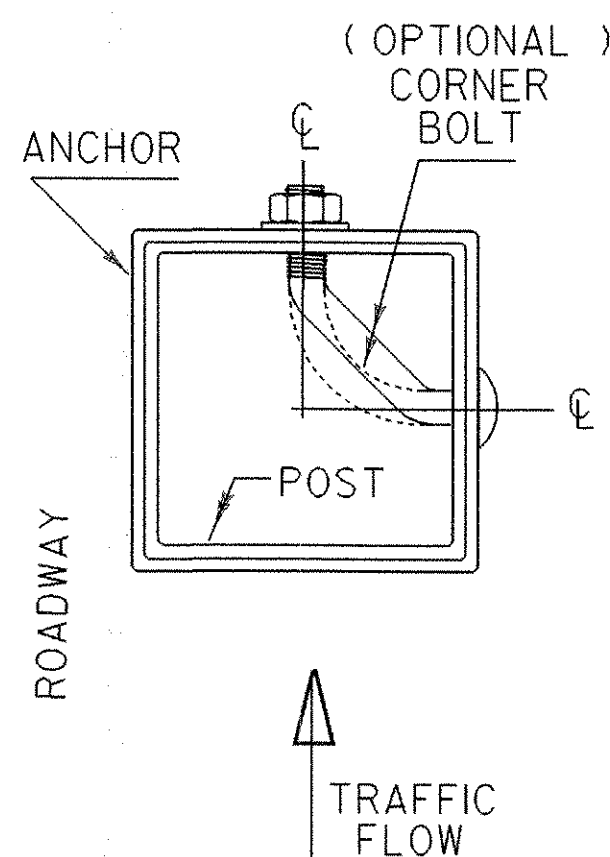

OPTIONAL CORNER BOLT DETAILS

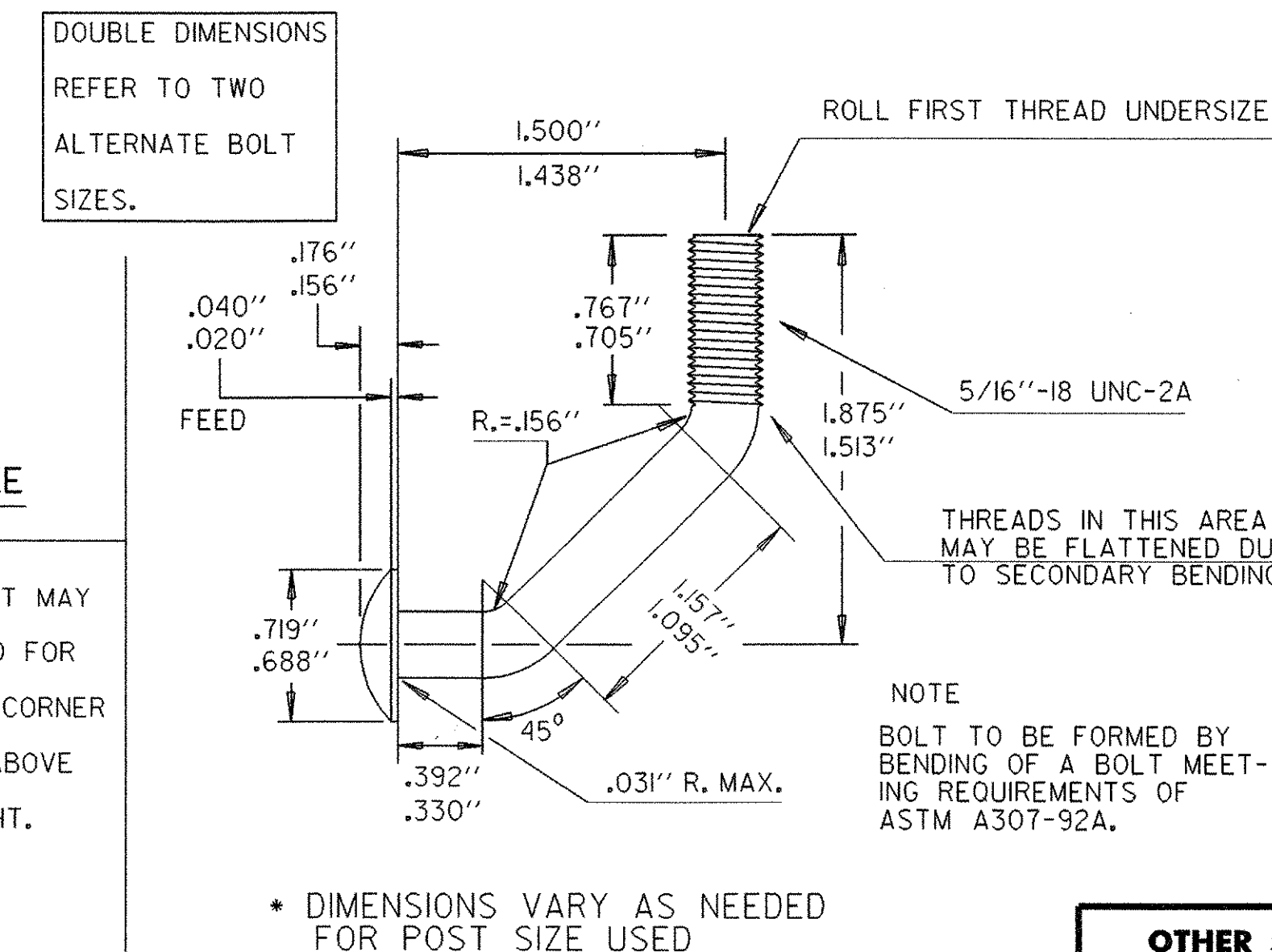

CONNECTION DETAIL

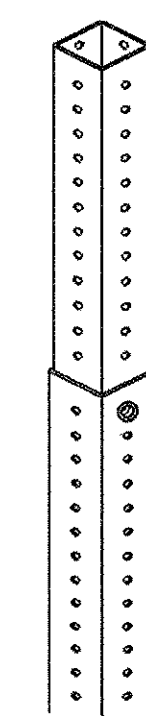

POST IS TO BE INSERTED INTO ANCHOR ONE FOOT BELOW GROUND LEVEL. ANCHOR IS TO BE 4'-0" MINIMUM LENGTH WITH NO MORE THAN 4" ABOVE GROUND. ANCHOR IS ONE SIZE (1/4") GREATER THAN THE POST AND ALL ANCHORS ARE TO BE 12 GAGE, EXCEPT ANCHORS FOR 2-1/2" POSTS ARE TO BE 3" AND 7 GAGE. CONNECTION IS TO BE MADE USING THE BOLT PROVIDED WITH THE SIGN SYSTEM (SEE DETAILS LEFT), AT THE TOP HOLE IN THE ANCHOR (APPROXIMATELY 3-1/2" ABOVE GROUND), THREE INCH ANCHORS WHICH DO NOT HAVE HOLES ON 1" CENTERS WILL REQUIRE DRILLING OF 7/16" HOLES FOR CONNECTIONS.

(SEE DETAIL LEFT FOR BOLT PLACEMENT)

OTHER STDS. E-120, E-160 REQUIRED

REVISIONS AND CORRECTIONS
APR. 27, 1994 - ORIGINAL APPROVAL DATE
JUL. 21, 1994 - REVISED POST GAUGES
AUG. 18, 1995 - ADDED TWO PIECE ANCHOR DETAIL
MAR. 26, 1996 - REVISED POST SELECTION CHART
MAY 20, 1999 - REPLACE LOST ORIGINAL
JUN. 08, 2009 - POST SELECTION REVISIONS

APPROVED

Kevin S. Marshe
HIGHWAY, SAFETY & DESIGN ENGINEER
Mark D. Reuther
DIRECTOR OF PROGRAM DEVELOPMENT
FEDERAL HIGHWAY ADMINISTRATION

SQUARE STEEL SIGN POST



STANDARD E-164