

FILE	SC610.1
REVISIONS	
09/27/10	XRL/TJF

LOCATION OF AUTOMATIC WARNING DEVICE WHERE CANTILEVERS AND GATES ARE REQUIRED

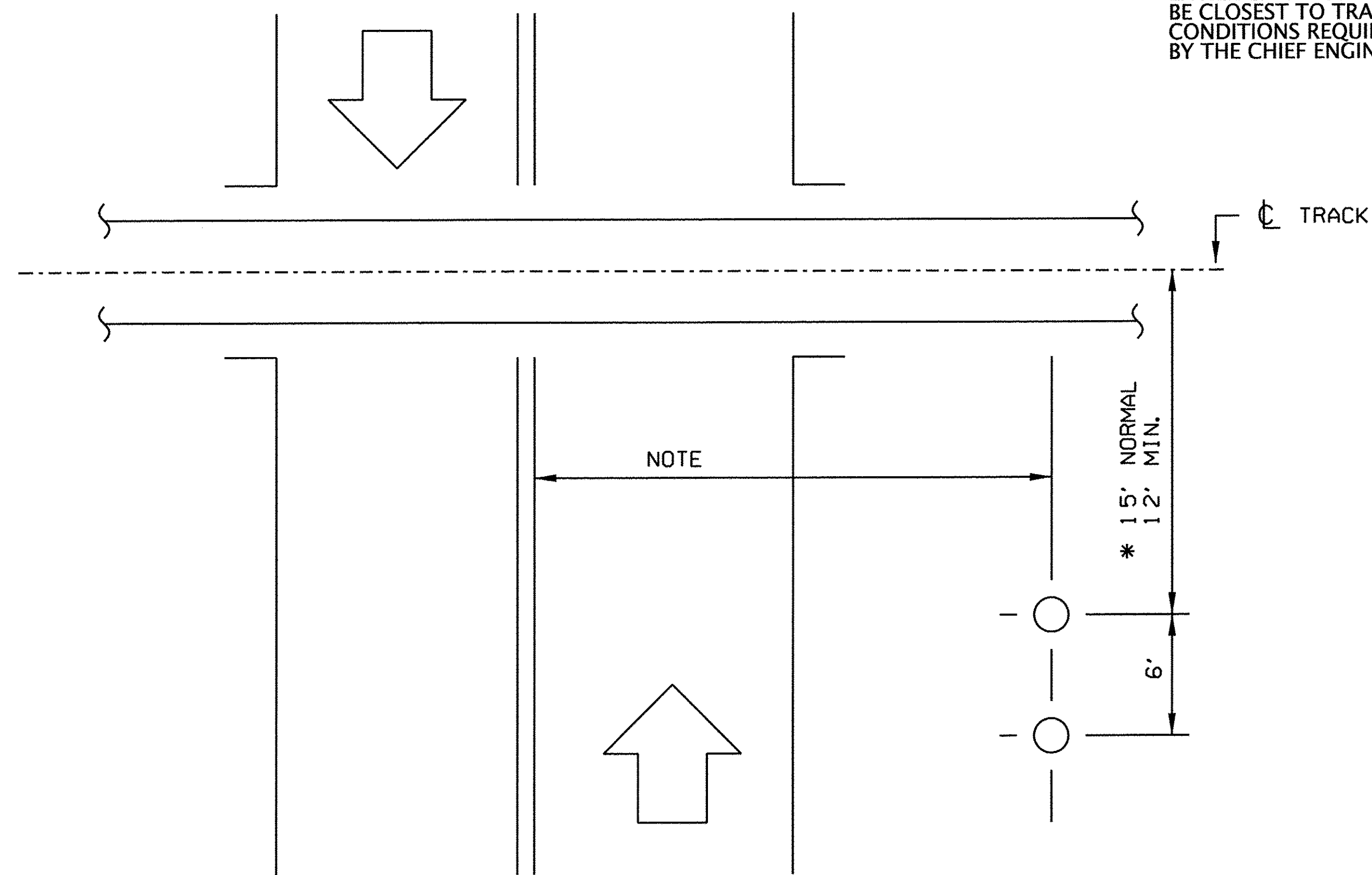

NOTE:  
EITHER CANTILEVER OR GATE MAY BE CLOSEST TO TRACK AS LOCAL CONDITIONS REQUIRE AND IF AUTHORIZED BY THE CHIEF ENGINEER.

LOCATION OF HOUSE FROM STREET AND TRACK

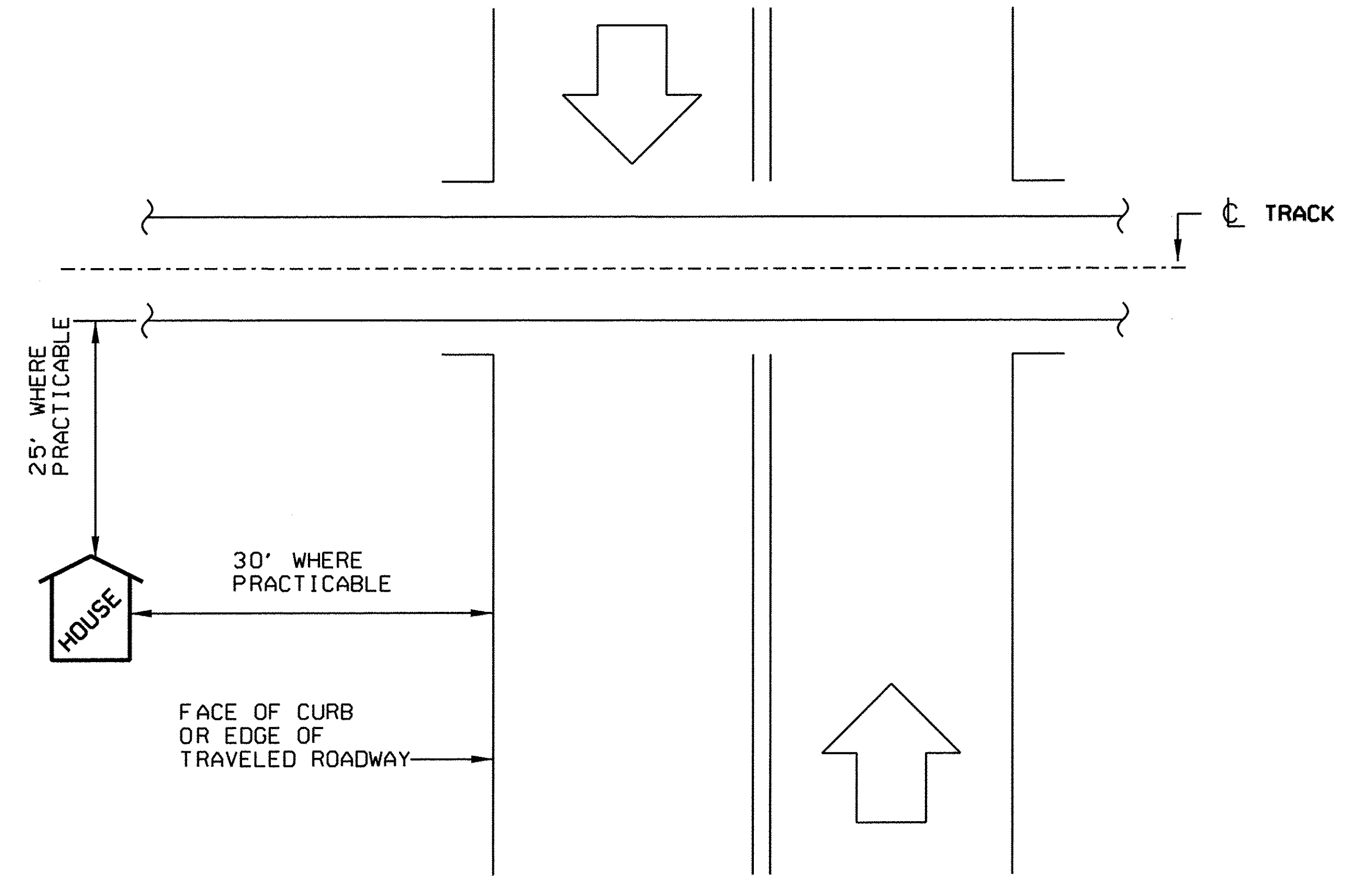

\* PLACEMENT SHALL NOT BE LESS THAN 15' UNLESS AUTHORIZED BY THE CHIEF ENGINEER.

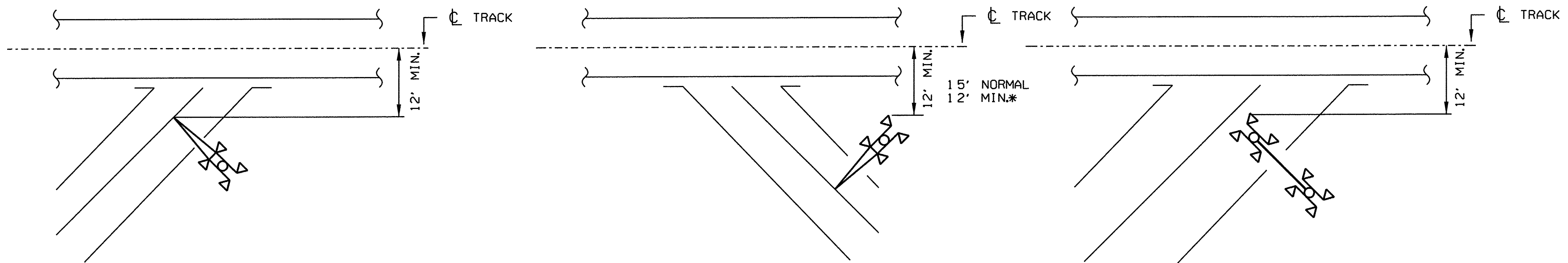

MINIMUM CLEARANCE OF AUTOMATIC WARNING DEVICES ANGLED CROSSINGS