

1 DIMENSIONAL PLAN
1/4" = 1'-0"

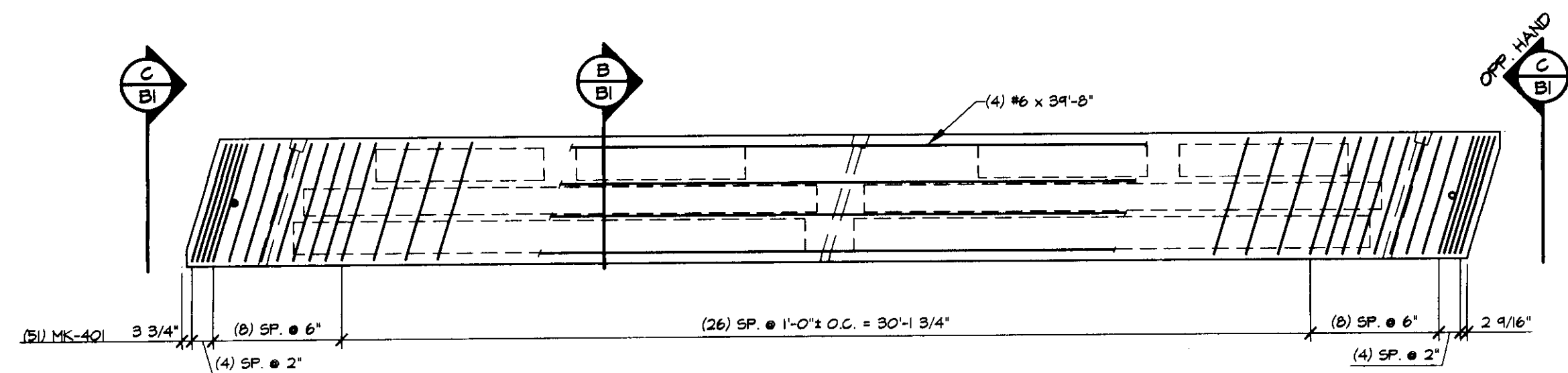

2 REINFORCING PLAN
1/4" = 1'-0"

SHOP NOTE:
ADJUST REINFORCING AS REQUIRED TO CLEAR TRANSVERSE TENDONS, ETC.

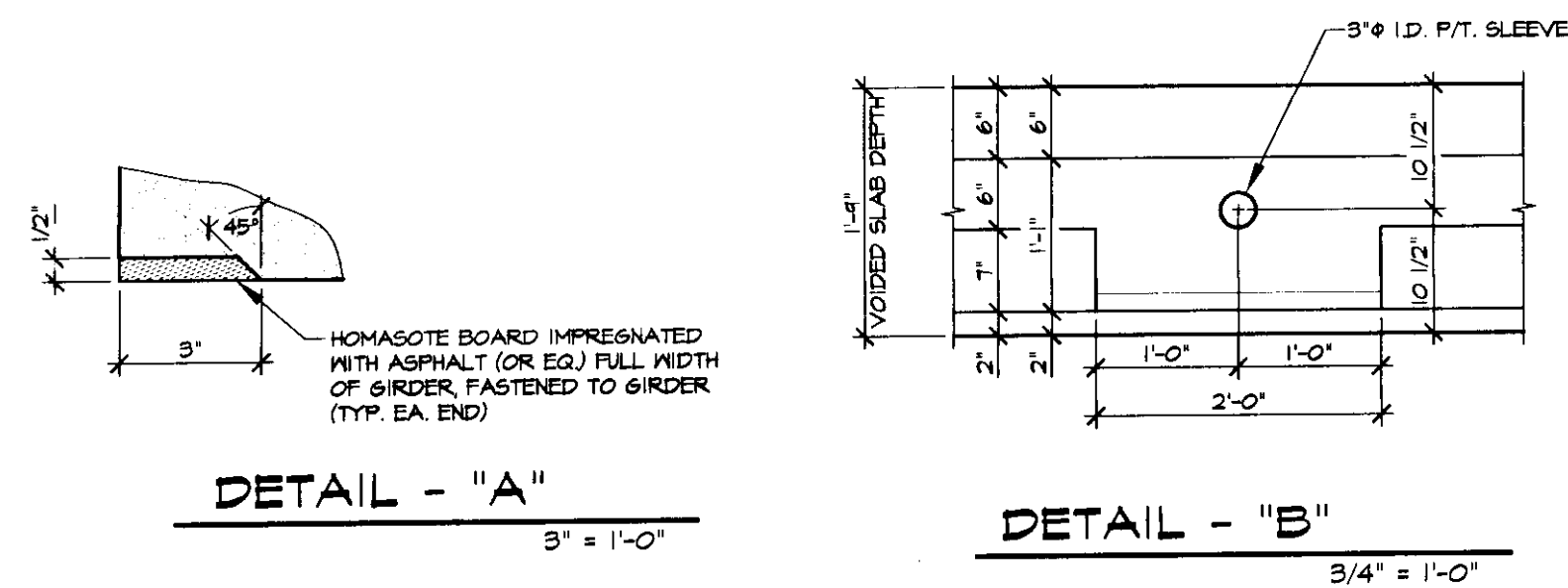

DETENSIONING SCHEDULE
N.T.S.

1	3	5	7	9	11	13	14	2	10	8	6	4	2
---	---	---	---	---	----	----	----	---	----	---	---	---	---

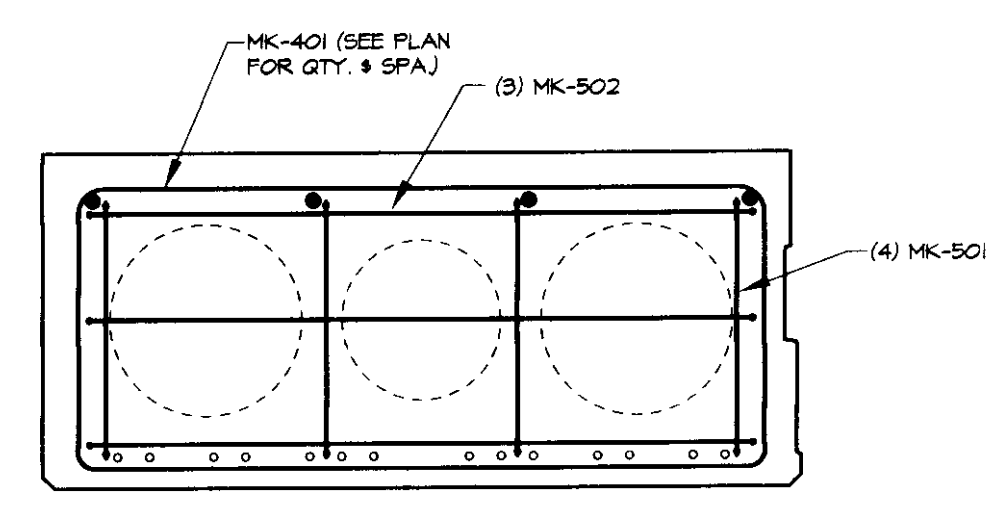

C END BLOCK REINFORCING ELEV.
3/4" = 1'-0"

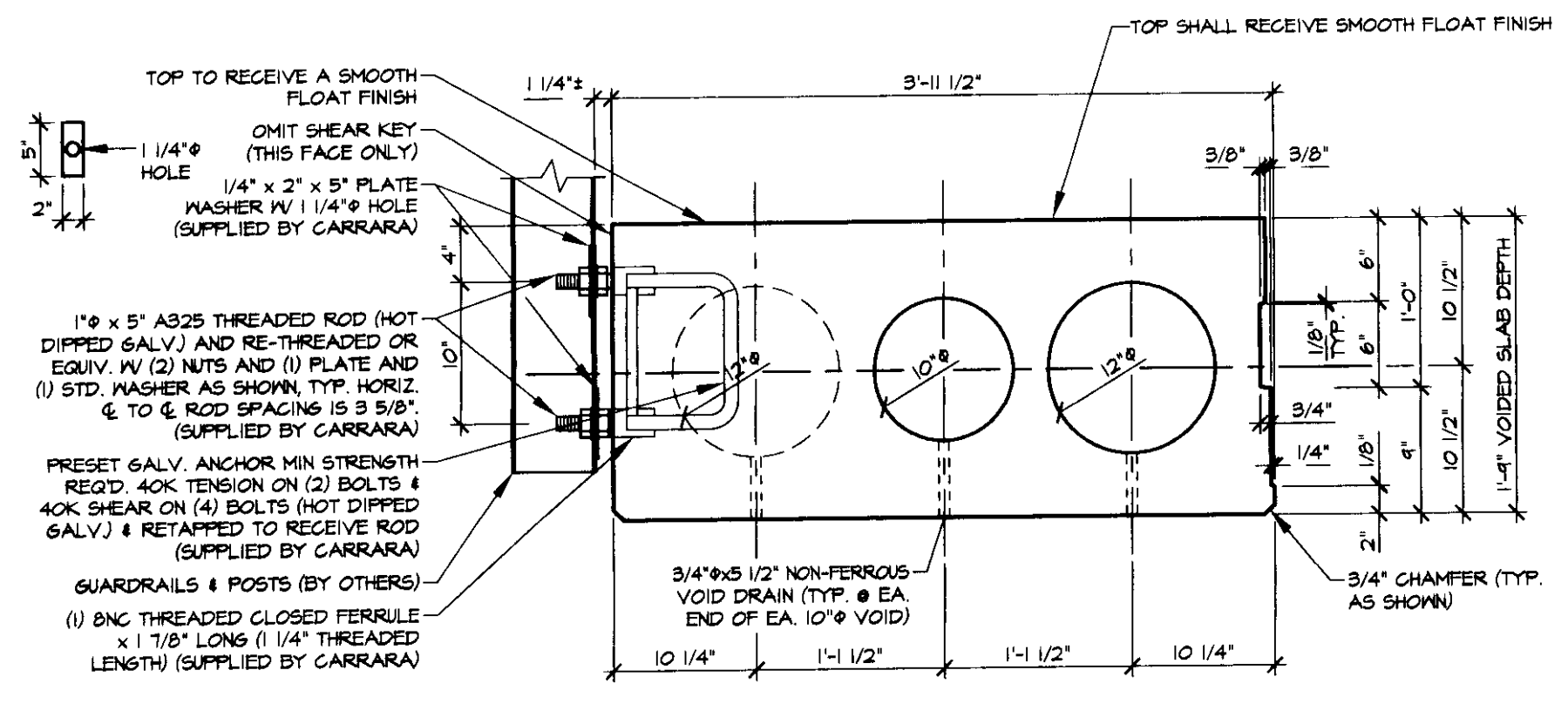

A DIMENSIONAL SECTION
1" = 1'-0"

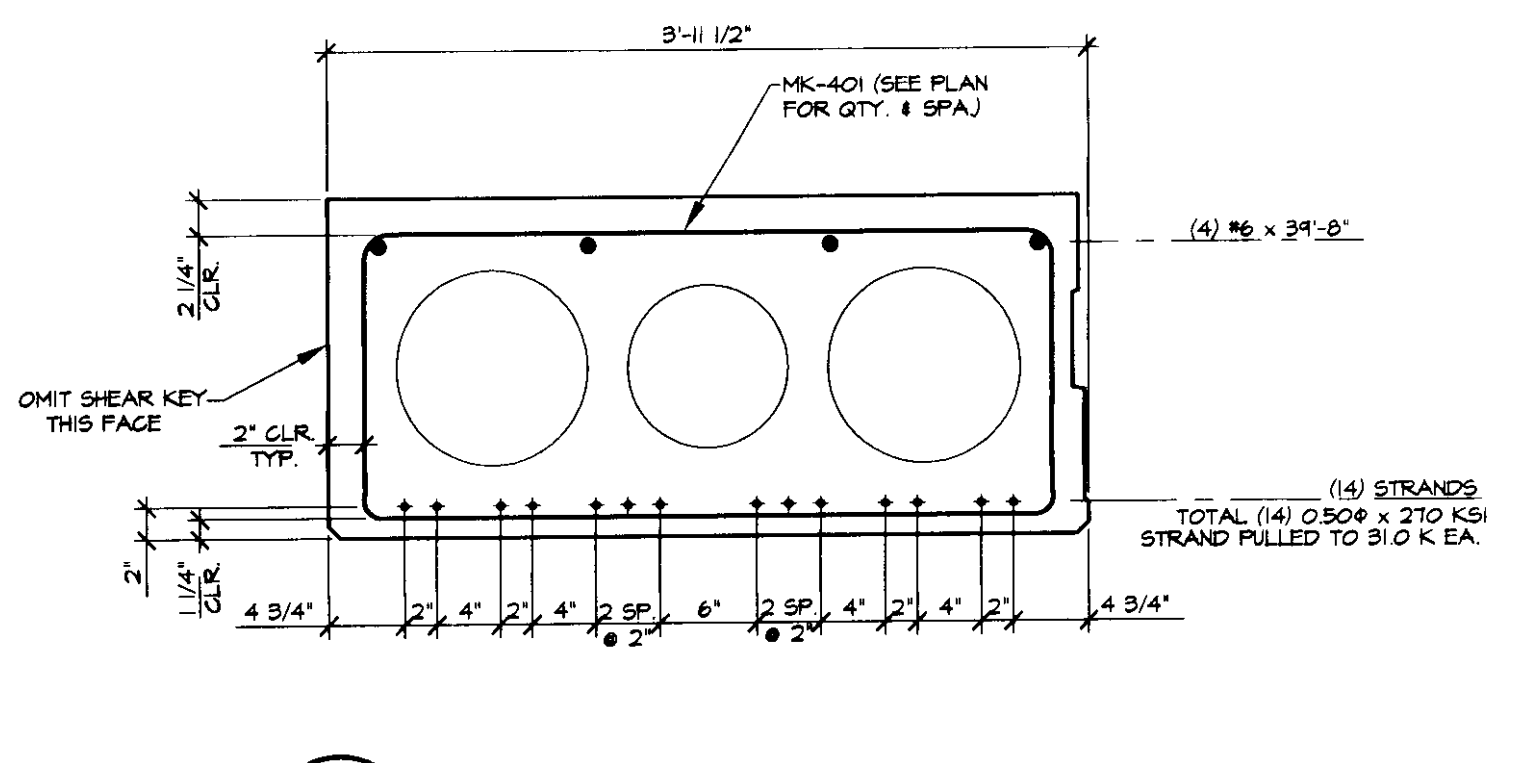

B REINFORCING SECTION
1" = 1'-0"

MARK: B-1	QTY.: 2	WT./TONS: 15.70	CU. YDS.: 7.75
MATERIAL LIST / VOIDED SLAB			
ITEM	MARK	DESCRIPTION	QTY.
1	401	#4 BENT BAR	51
2			
3	501	#5 BENT BAR	8
4	502	#5 BENT BAR	6
5			
6		#6 x 39'-8"	4
7			
8		12" x 5'-3" VOID	4
9		10" x 16'-0" VOID	2
10		12" x 16'-0" VOID	2
11		3/4" x 4 1/2" NON-FERROUS VOID DRAIN	16
12		DOUBLE 1/2" STRAND LIFTING LOOP	4
13			
14			
15			
16			
17			
18			
19			
20			
21			
22			

APPROVAL STAMP:

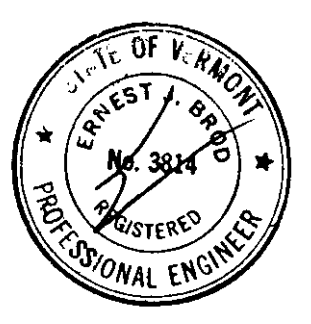

J.P. CARRARA & SONS INC.
Precast & Prestress Manufacturer
2464 CASE STR., MIDDLEBURY, VERMONT 05751 Phone: (802)388-6361 Fax: (802)388-9010

J.P. CARRARA & SONS INC.
CONTRACTOR
MIDDLEBURY, VERMONT

BRIDGEWATER #46 BRIDGE
BRIDGEWATER, VT

TOWN OF BRIDGEWATER
P.O. BOX 14 SOUTH GATEHOUSE
BRIDGEWATER, VT 05034

P/S VOIDED SLAB DETAILS

DATE: JUNE 18, 2001
SCALE: NOTED
CHKD: - DFTM: K.B.
JOB NO: 23162-02
DWG. NO: B1