

STRUCTURAL
STEEL

76

A B C Testing Inc.

95 FIRST STREET • P.O. BOX 868 • BRIDGEWATER, MASSACHUSETTS 02324
TELEPHONE 508 - 697 - 6068 • FAX # 508 - 697 - 6154

FILLET PROCEDURE QUALIFICATION REPORT

TO L.B. Foster Company
3 Farm Lane
Georgetown, MA 01833

Client's Order No. transmittal (W. Borkowski)
ABC Project No. 124009
Date December 23, 2009

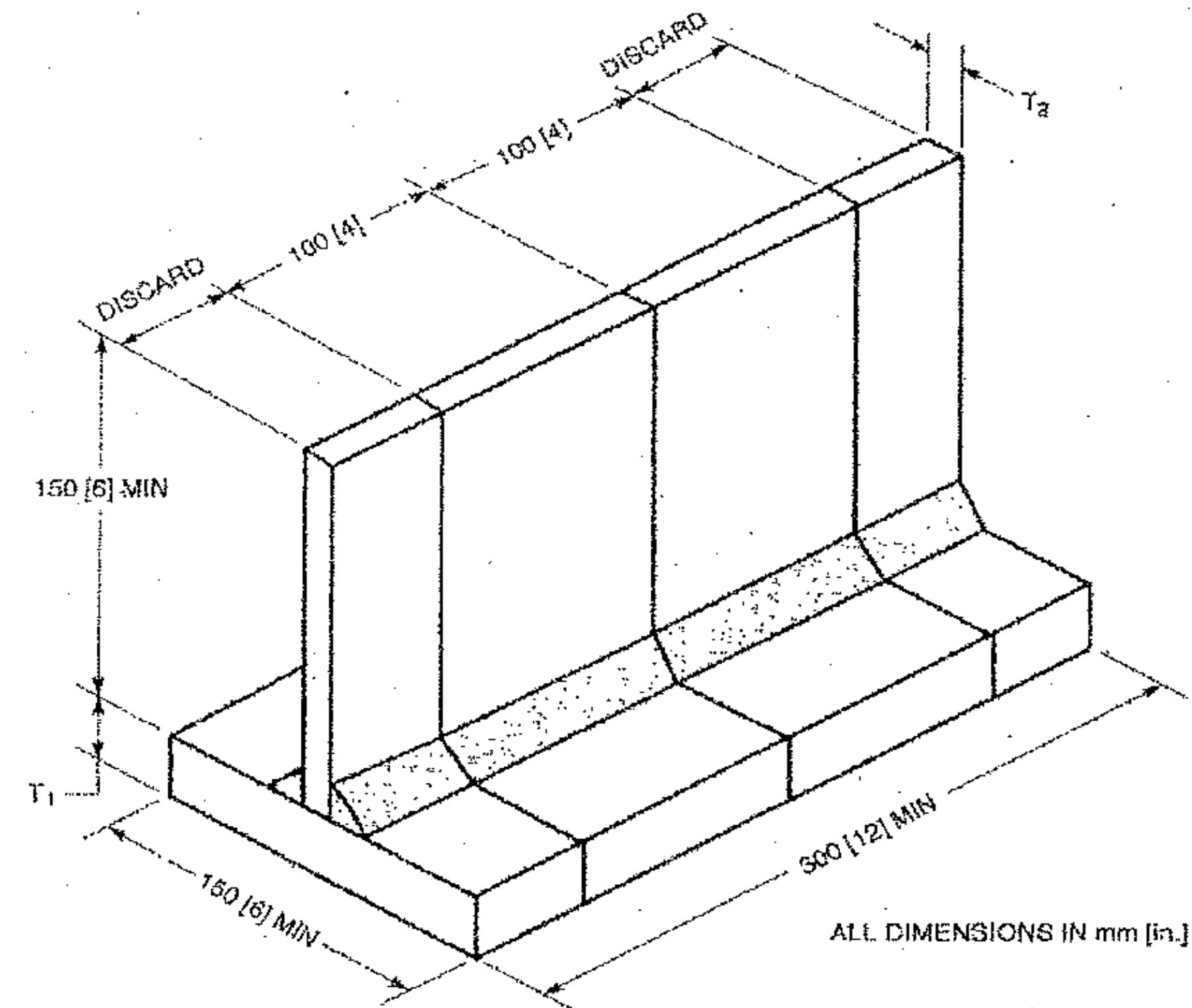

Welders Name: Mariano Cepeda

Material & Dimensions: ASTM A709, grade 50 (T₁ = 1 inch, T₂ = 1 inch)

Figure number: figure 5.8

Position: horizontal (2F)

Visual test result: acceptable

Macroetch result: acceptable (3 locations)

Remarks: _____

All testing was conducted in accordance with the referenced Standard
Vermont Agency of Transportation

RECEIVED

CK'D BY WDL OK'D BY JWC

By: Bruce M. Richardson

11:43 am, Jul 11, 2011

Bruce M. Richardson

RESUBMIT _____ APPROVED
BY CWC, Proj. Mgr. DATE 07/19/11