

BILL OF MATERIAL										JOB NO.	DRAWING NO.	REV.
ABN INFO	SHIP	QTY	MARK	MATERIAL	LENGTH	REMARKS	HT	PROCUREMENT NOTES				
PAGE	LINE				FT							
				1025 + 625								
2	B	2	xla	PL 3/4 x 7 1/2	4 7	(A209-S0W) MIF						
2	B	2	xlb	PL 3/4 x 7 1/2	4 7	(A209-S0W) MIF						
2	C	4	xlc	PL 1/2 x 7 1/2	4 7	(A209-S0W)						
2	E	11	xik	L 4x4x3/8	0 8	(A209-S0W)						
2	F	1	xim	PL 1/2 x 3 1/2	0 11	(A209-S0W)						
2	F	1	xin	PL 1/2 x 3 1/2	0 11	(A209-S0W)						
4	B	22		7/8 HSB	0 2 1/2	(A325-3)						
4	D	22		7/8 HSW	0 2 1/2	(F438H)						

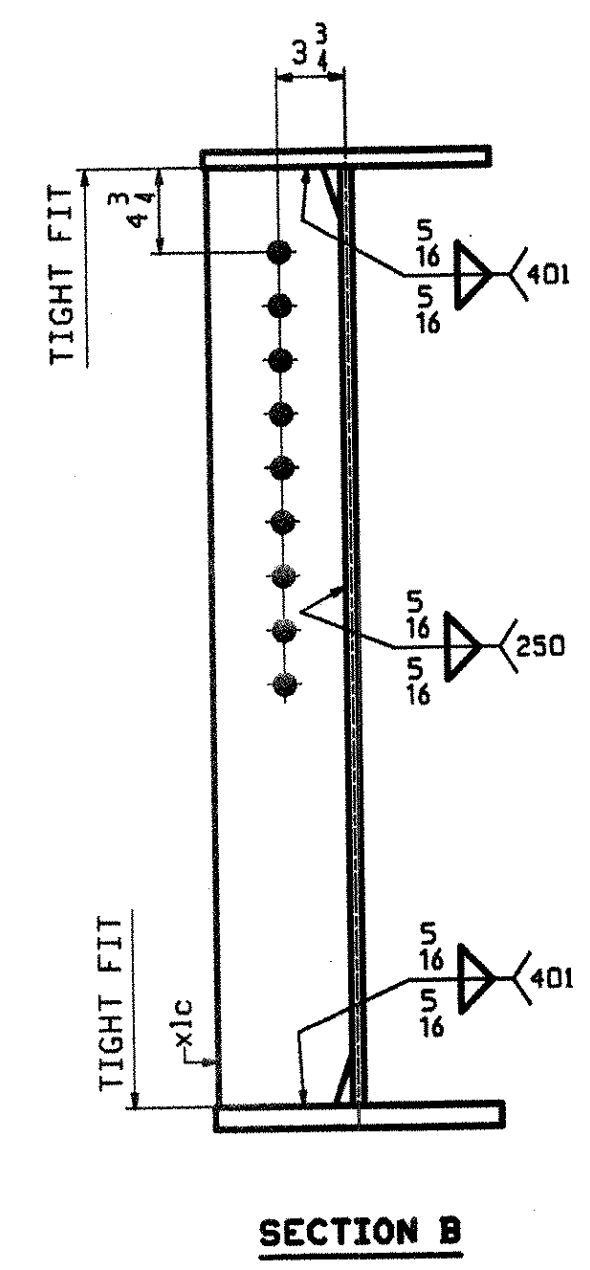

ONE - GIRDER - 1G1
 FOR GIRDER STANDARDS SEE DRAWING XI.
 FOR CAMBER & FLANGE DIAGRAMS SEE DRAWING C1.
 FOR GENERAL NOTES SEE DRAWING GNI.
 H2-3 DENOTES MATERIAL SUBJECT TO CHARPY V-NOTCH TESTING.

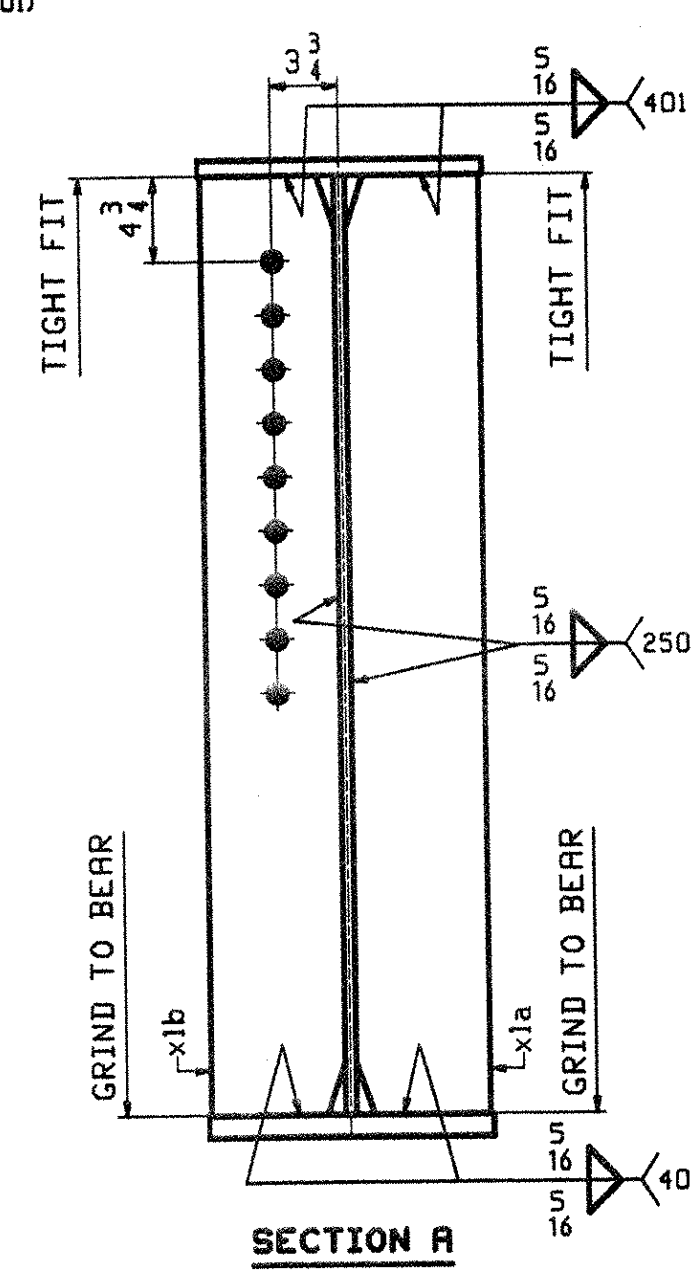
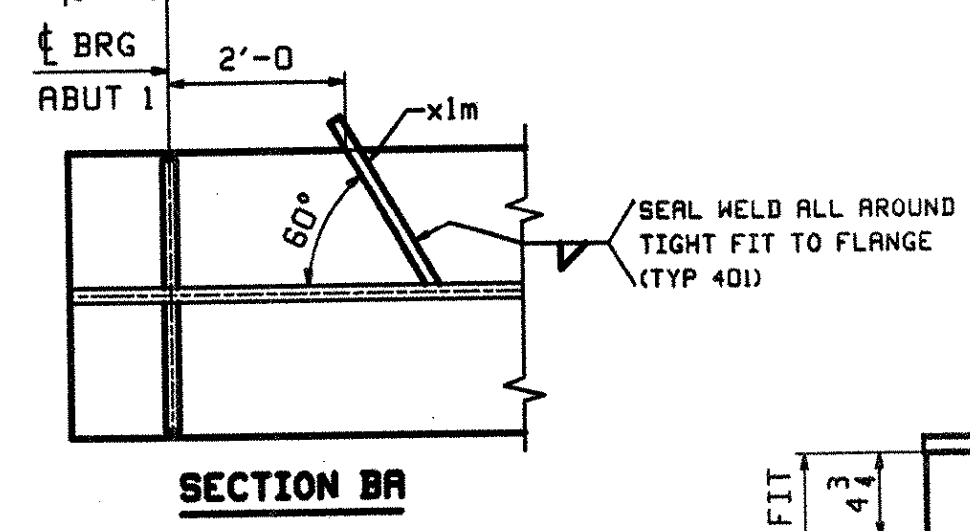
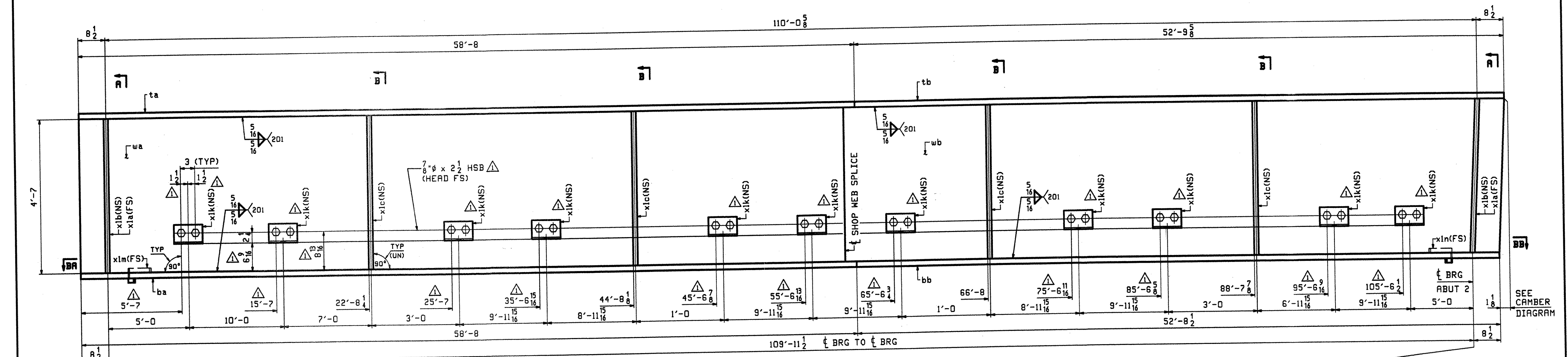
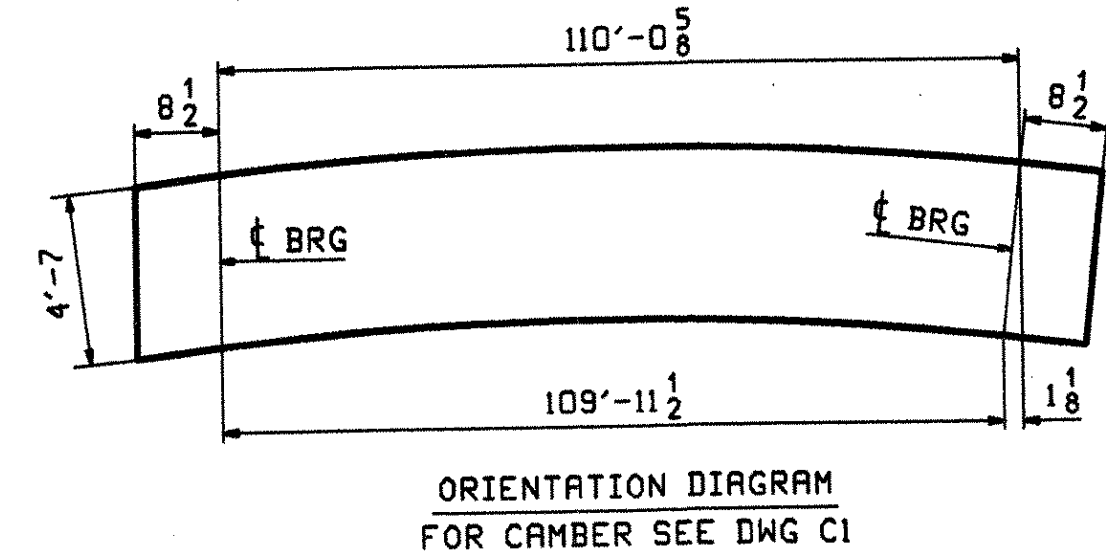
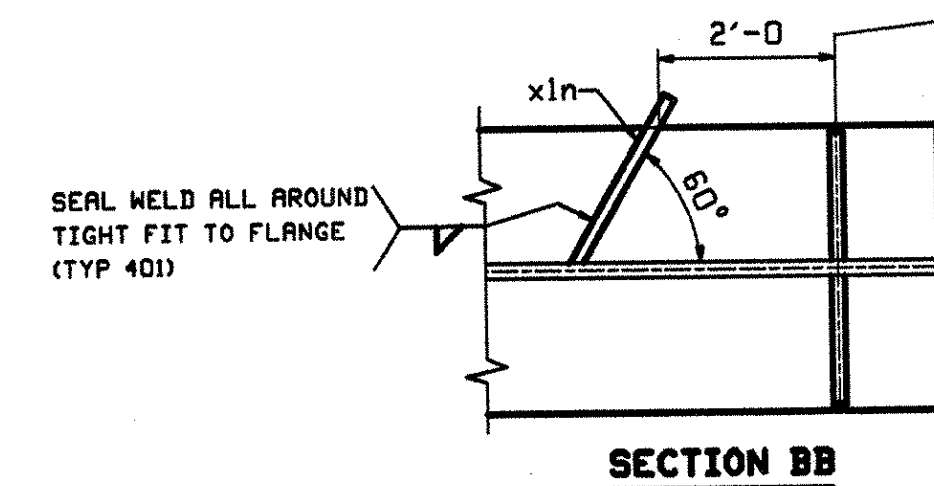

OUT FOR APPROVAL	6-14-07											
OUT FOR APPROVAL	7-20-07											
ISSUED TO SHOP												
FIELD & OFFICE												
APPROVAL COMMENTS	7/5 2007	JTB	ELC									
REV. REMARKS	DATE	DWN	CHK	APP	O.A.	NO.	DIA.	LGT	TYPE	WASHER		
MATERIAL:	A709-50W (UN)											
ELECTRODES:												
HOLES:	1 1/2" (UN)											
SHOP BOLTS:	NONE											
SURFACE PREP. & PAINT: SEE DRAWING GNI												
DESCRIPTION:	GIRDER - 1G1										DRAWN BY	DATE
JOB:	TOWN HIGHWAY #3 OVER WILLOUGHBY RIVER BRIDGE NO. 61 TOWN OF BARTON, VILLAGE OF ORLEANS COUNTY OF ORLEANS, VERMONT CONTRACTOR: JA McDONALD										JTB	06/07
											CHKD BY	
											ELC	06/07
											APPROV BY	
											SUPERVISOR	W. J. GATTI
PROJ NO.	BRO 1449(28)										Q.A.	
CUSTOMER:	VERMONT ROT											
CASCO BAY STEEL STRUCTURES, INC.											JOB NO.	DRG. NO.
75 SPRING HILL ROAD SACO, MAINE 04072											328	1
PHONE (207) 282-7360 FAX. (207) 282-1179											REV.	1

5/3/10 TWP
 7/5/00 BERT
 1/30/02 WEDBY
 2/5/02