

TYPICAL PLAN VIEW  
MAIN STREET CROSSING

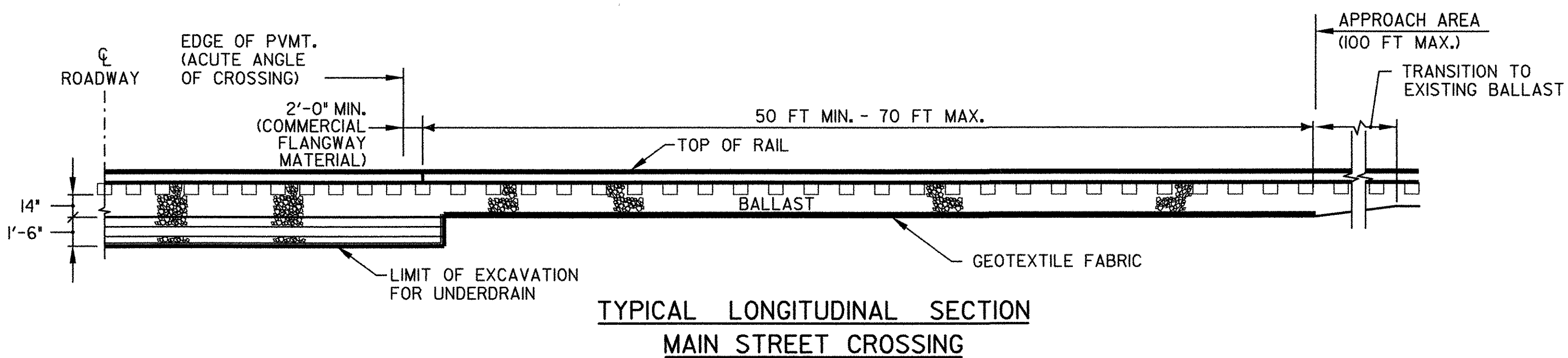

TYPICAL LONGITUDINAL SECTION  
MAIN STREET CROSSING

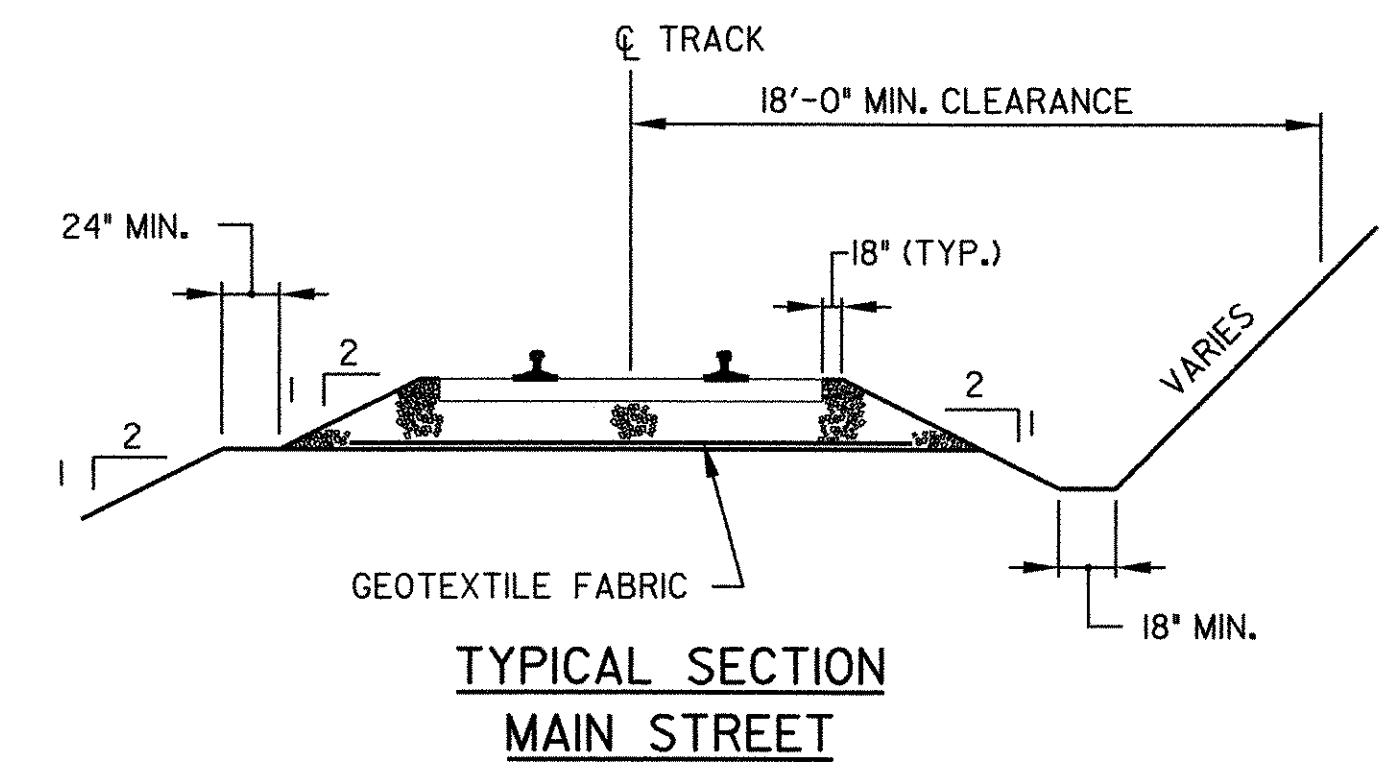

TYPICAL SECTION  
MAIN STREET

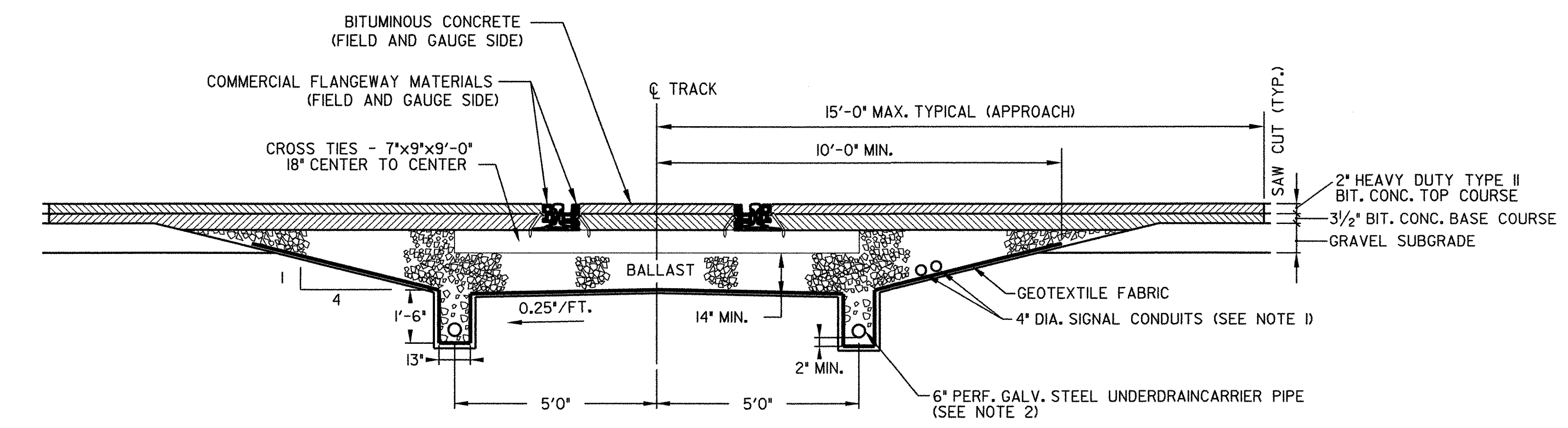

TYPICAL TRANSVERSE SECTION  
MAIN STREET CROSSING

**GENERAL NOTES**

- ON RICHVILLE ROAD THE EXISTING SIGNAL CONDUIT IS TO REMAIN AND THE CONTRACTOR SHALL BE CAREFUL DURING HIS EXCAVATION. IF THE CONTRACTOR DAMAGES THE SIGNAL CONDUIT HE SHALL REPLACE IT AT NO ADDITIONAL COST TO THE PROJECT. CONTRACTOR TO VERIFY LOCATION OF SIGNAL CONDUIT.
- NEW UNDERDRAIN CARRIER PIPE SHALL CONNECT TO EXISTING CATCH BASIN. PERFORATIONS TO BE PLACED NEAR FLOW LINE OF PIPE.
- ALL RAIL JOINTS WITHIN THE CROSSING AREA AND 50'-0" BEYOND WILL BE CROPPED AND WELDED IN ACCORDANCE WITH THE LATEST REVISION OF A.R.E.M.A. SPECIFICATIONS AT AN OFF-SITE ELECTRIC WELDING PLANT. WELDING CAN BE DONE IN FIELD UTILIZING THERMITE WELDING WITH ADVANCE APPROVAL FROM THE AGENCY. WELDED JOINTS SHALL BE GROUND TO CONFORM TO THE SHAPE OF THE RAIL ON GAUGE AND FIELD SIDES.
- TIE SPACING UNDER CWR AREA SHALL BE 18 INCHES ON CENTER OR AS REQUIRED IN CROSSING PANEL AREA BY MANUFACTURER.
- NEW 7"x9"x9'-0" AND 7"x9"x8'-6" TIES SHALL BE USED IN CROSSING AREA AS SHOWN. TIES IN APPROACH AREAS SHALL BE REPLACED AS RECOMMENDED BY THE RAILROAD AND APPROVED BY THE ENGINEER.
- TIE PLATES SHALL BE NEW 14 INCH PLATES, MANUFACTURED FOR THE RAIL SIZE USED. PLATES SHALL BE INSPECTED AND APPROVED BY THE RAILROAD AND THE ENGINEER. RAIL FASTENERS SHALL BE CUT TRACK SPIKES.
- BALLAST SHALL EXTEND 18" BEYOND END OF TIES AND SLOPED 1:2 TO THE ROADBED. (SEE DETAIL)
- TYPE AND DESIGN OF COMMERCIAL FLANGEWAY MATERIALS SHALL RECEIVE APPROVAL FROM THE ENGINEER.
- MANUFACTURERS SPECIFICATIONS SHALL BE FOLLOWED FOR THE INSTALLATION OF COMMERCIAL FLANGEWAY MATERIALS.
- INSTALLATION OF INSULATED JOINTS: THE MAXIMUM STAGGER BETWEEN RAIL JOINTS SHALL BE 4'-6", MINIMUM SHALL BE 3'-6".
- APPROACH ASPHALT ROADWAY PAVING SHALL FOLLOW LATEST EDITION OF THE AGENCY'S STANDARD SPECIFICATION FOR CONSTRUCTION AND SHALL BE INSTALLED WITH PAVING MACHINE WITH MINIMUM 3" LIFTS (UNLESS OTHERWISE DIRECTED BY THE ENGINEER) AND SHALL BE LAID PARALLEL TO CROSSING TO MINIMIZE APPROACH SETTLEMENT.
- EXISTING TRACK IS CONTINUOUS WELDED RAIL, JOINT SHALL BE FIELD WELDED OR BOLTED AS SHOWN ON THE PLANS. TRANSITION RAIL SHALL BE NEW AND MATCH RAIL SECTION THROUGH CROSSING, IF REQUIRED.
- CONTRACTOR SHALL ADD BALLAST, LINE, TAMP, AND SURFACE TRACK IN APPROACH AREAS TO OBTAIN A SMOOTH TRANSITION BETWEEN EXISTING AND PROPOSED TRACK TO THE SATISFACTION OF THE ENGINEER AND RAILROAD. THIS WORK IS INCIDENTAL TO THE RAIL-HIGHWAY CROSSING ITEM.
- JOINTS SHOULD BE A MINIMUM OF 50'-0" AND A MAXIMUM OF 70'-0" FROM EDGE OF TRAVELED WAY.

NOT TO SCALE

PROJECT NAME:	NORTH BENNINGTON
PROJECT NUMBER:	STP 203(10) TH#3; STP 1200(4) TH#1
FILE NAME:	Z0IG58RRDETAILS2.DGN
PROJECT LEADER:	D. BUA
DESIGNED BY:	ASL
PLOT DATE:	08-MAY-2006
DRAWN BY:	LB
CHECKED BY:	BUA
SHEET	20 OF 21

P701030064