

DROP INLET PROTECTION

APPLICATION NOTES:

- A. THE PRIMARY PURPOSE OF DRAINAGE STRUCTURE INLET PROTECTION IS TO PREVENT SEDIMENT FROM ENTERING A DRAINAGE SYSTEM BY PONDING WATER WHICH ALLOWS SEDIMENT TO FALL OUT OF SUSPENSION.
- B. THESE EXAMPLES OF DROP INLET PROTECTION ARE NOT INTENDED FOR USE ON GRADES. ON GRADE THEY MAY CAUSE WATER TO BYPASS THE STRUCTURE, CREATING ADDITIONAL EROSION OR FLOODING.
- C. POSSIBLE MODIFICATIONS FOR USE ON GRADE INCLUDE ADDING A BERM DOWNSTREAM OF THE INLET TO CREATE PONDING. CHECK DAMS MAY ALSO BE USED UPSTREAM OF THE INLET TO SLOW VELOCITIES.
- D. PREFABRICATED DROP INLET PROTECTION SPECIFICATIONS SHALL BE PROVIDED TO THE ENGINEER FOR APPROVAL PRIOR TO USE.

GENERAL NOTES:

1. THE TOP OF THE INLET PROTECTION SHALL BE SET AT THE MAXIMUM DESIRED WATER LEVEL, BASED ON FIELD LOCATION AND CONDITIONS.
2. SILT FENCE GEOTEXTILE SHALL BE A SINGLE CONTINUOUS PIECE TO ELIMINATE JOINTS.
3. SPACE SILT FENCE POSTS EVENLY AROUND INLET WITH A MAXIMUM SPACING OF 3 FEET. DRIVE POSTS A MINIMUM OF 18 INCHES INTO GROUND. WIRE MESH MAY BE REQUIRED BEHIND GEOTEXTILE TO PROVIDE SUPPORT.
4. SILT FENCE GEOTEXTILE SHALL BE EMBEDDED A MINIMUM OF 6 INCHES AND BACKFILLED. GEOTEXTILE SHALL BE SECURELY FASTENED TO POSTS AND FRAME.
5. GRAVEL BAGS SHALL BE FILLED WITH CLEAN STONE, RATHER THAN SAND, TO PREVENT SEDIMENT FROM ENTERING A DRAINAGE SYSTEM IF BAGS ARE DAMAGED DURING USE.
6. GRAVEL BAGS SHALL BE INDIVIDUALLY TIED, DOUBLE BAGGED AND INVERSELY INSERTED. GRAVEL BAGS SHALL LAP THE JOINTS BETWEEN THE BAGS IN THE LAYER BELOW.
7. SECURE THE ENDS OF THE APRON FOR THE PREFABRICATED DRAINAGE STRUCTURE INLET PROTECTION WITH STAPLES AS DETAILED IN THE PLAN VIEW OR AS RECOMMENDED BY THE MANUFACTURERS LITERATURE.
8. MEASURES SHALL BE INSPECTED EVERY SEVEN (7) CALENDAR DAYS AND WITHIN 24 HOURS OF A STORM EVENT GREAT ENOUGH TO CAUSE WATER TO LEAVE THE CONSTRUCTION SITE.
9. MEASURES SHALL BE CLEANED AND REPAIRED AS NEEDED, SEDIMENT SHALL BE REMOVED WHEN ACCUMULATION REACHES ONE-HALF OF THE MEASURE HEIGHT. SEDIMENT SHALL BE DISPOSED OF AS UNSUITABLE MATERIAL.
10. PAYMENT FOR INLET PROTECTION SHALL BE MADE UNDER STONE FILL, TYPE I (MOD. - INLET PROTECTION)
11. PAYMENT FOR MONITORING INLET PROTECTION SHALL BE MADE UNDER THE MONITORING EROSION PREVENTION & SEDIMENT CONTROL PLAN ITEM.
12. PAYMENT FOR MAINTAINING INLET PROTECTION SHALL BE MADE UNDER THE MAINTENANCE OF EROSION PREVENTION & SEDIMENT CONTROL PLAN ITEM, UNLESS MAINTENANCE IS REQUIRED DUE TO POOR INSTALLATION PRACTICES.

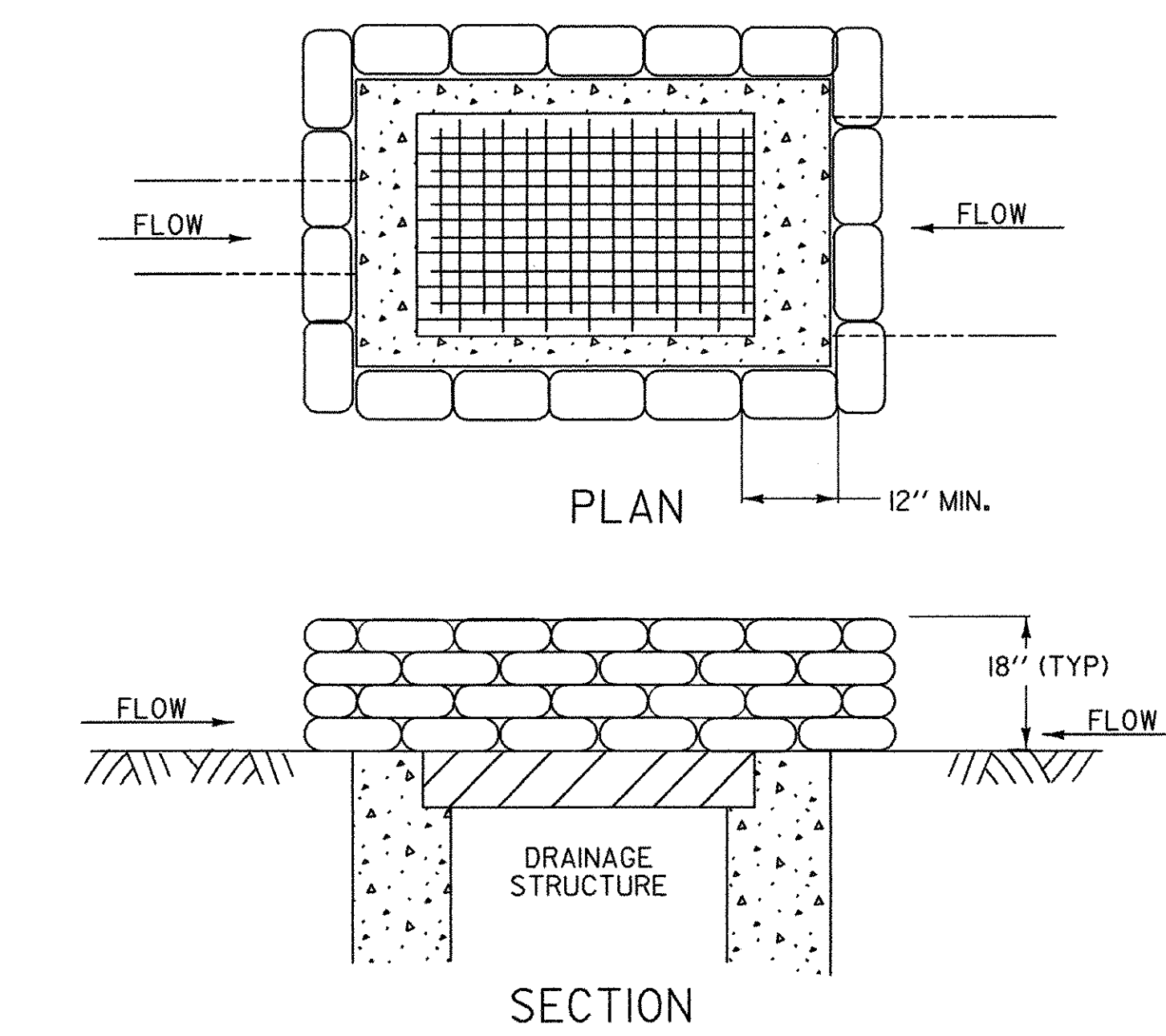

GRAVEL BAG DROP INLET PROTECTION

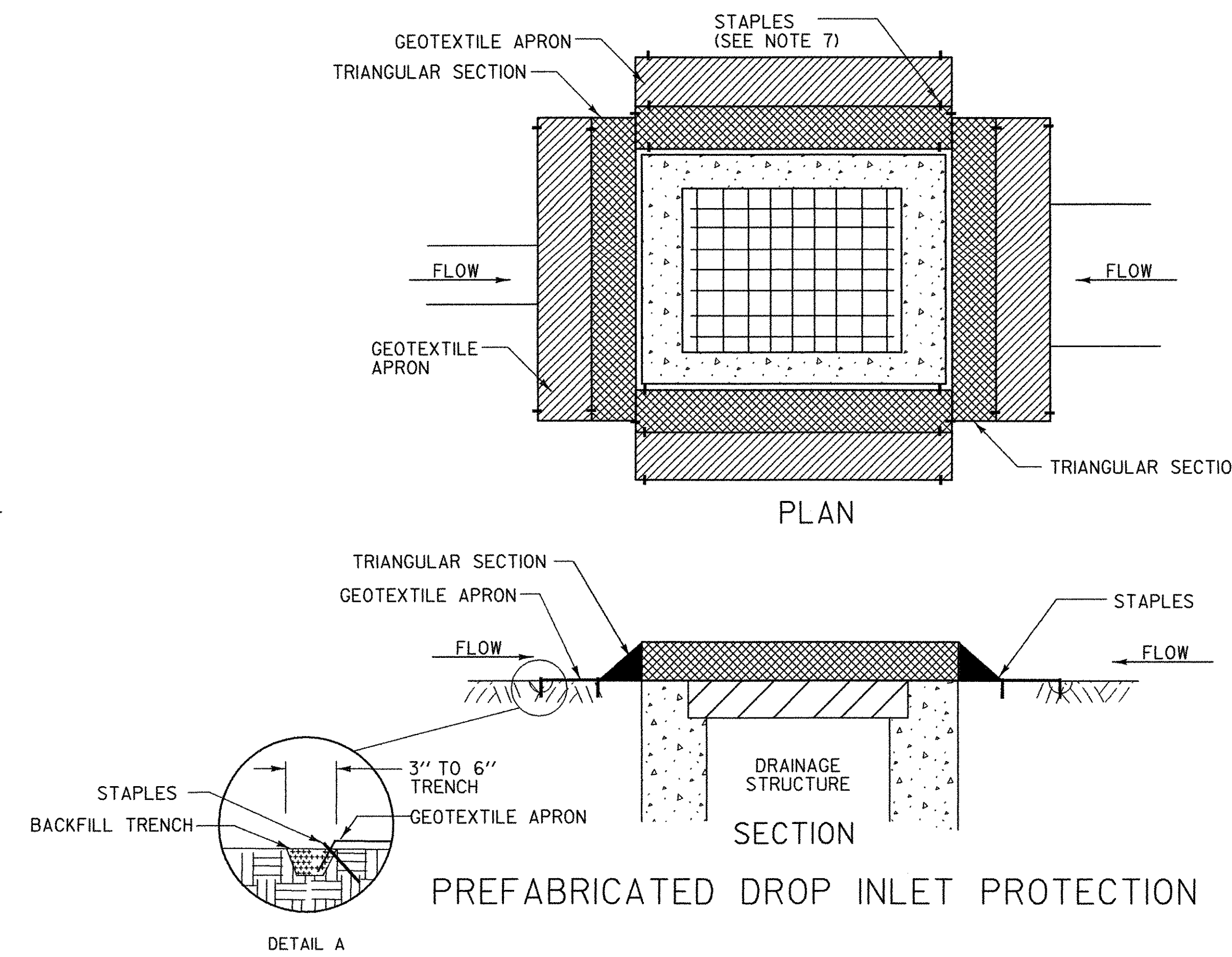

PREFABRICATED DROP INLET PROTECTION

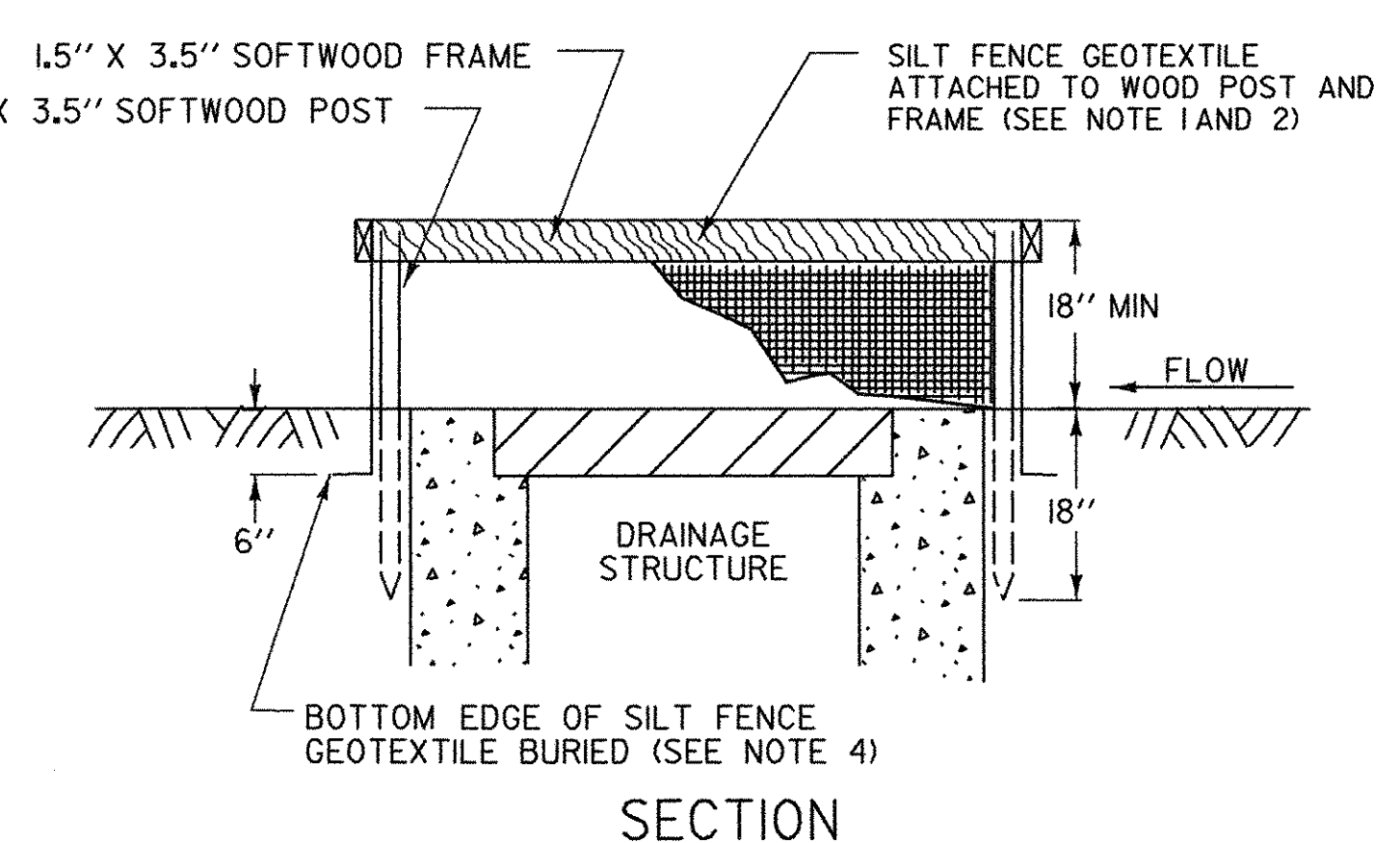
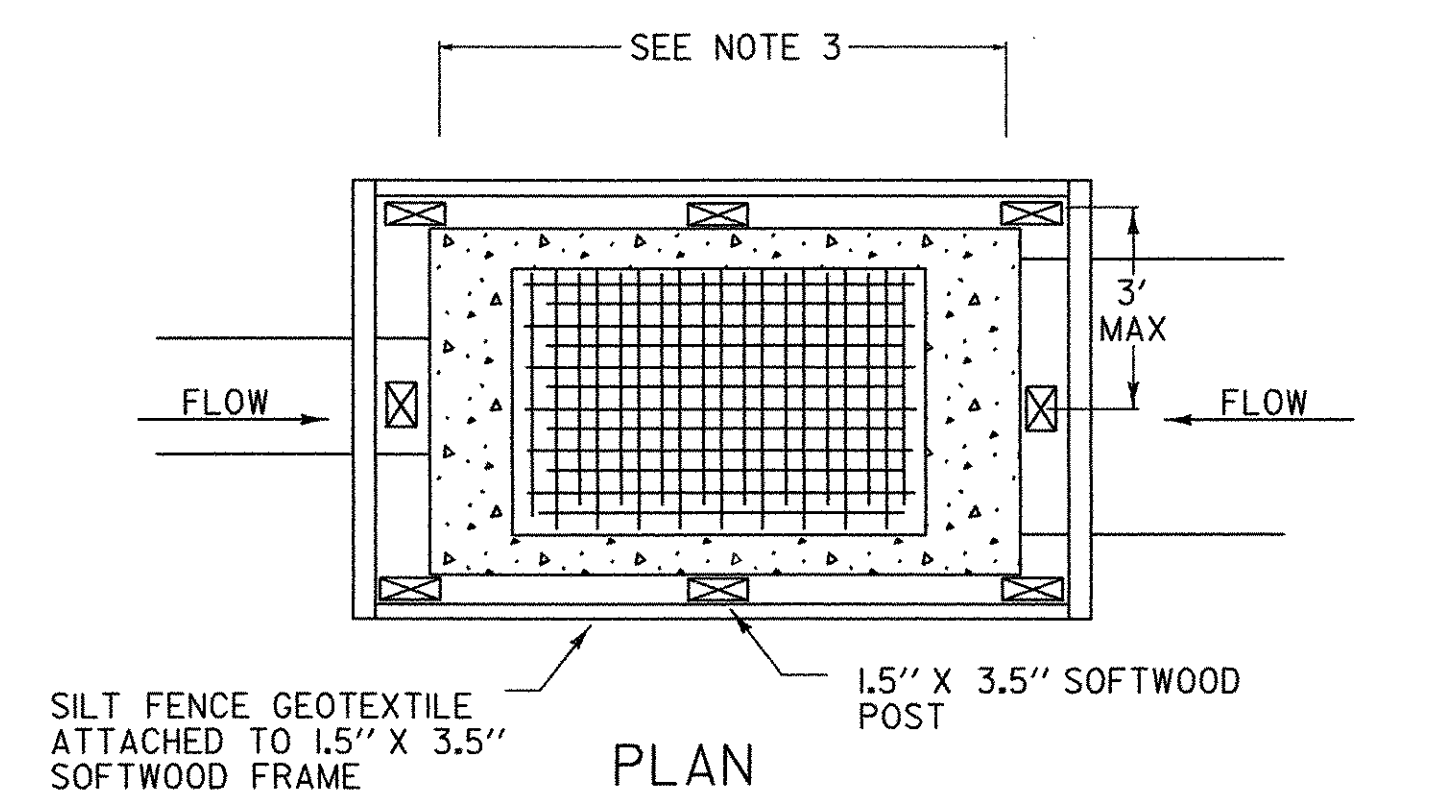

SILT FENCE DROP INLET PROTECTION

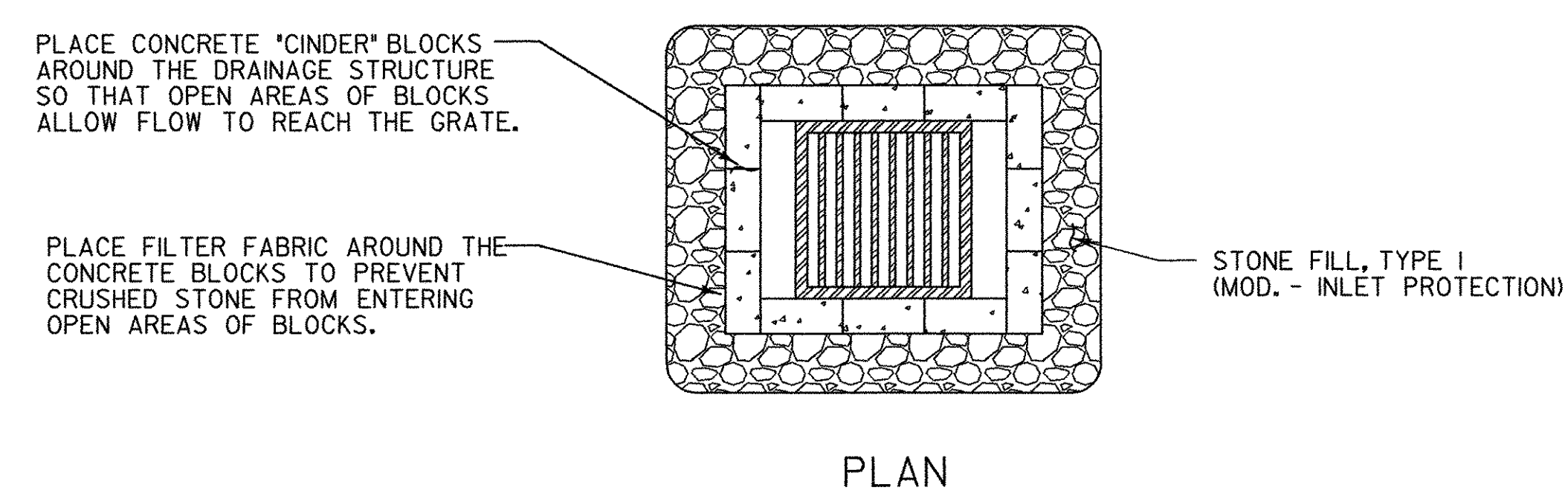

ROCK BARRIER DROP INLET PROTECTION
TEMPORARY PAVED AREAS

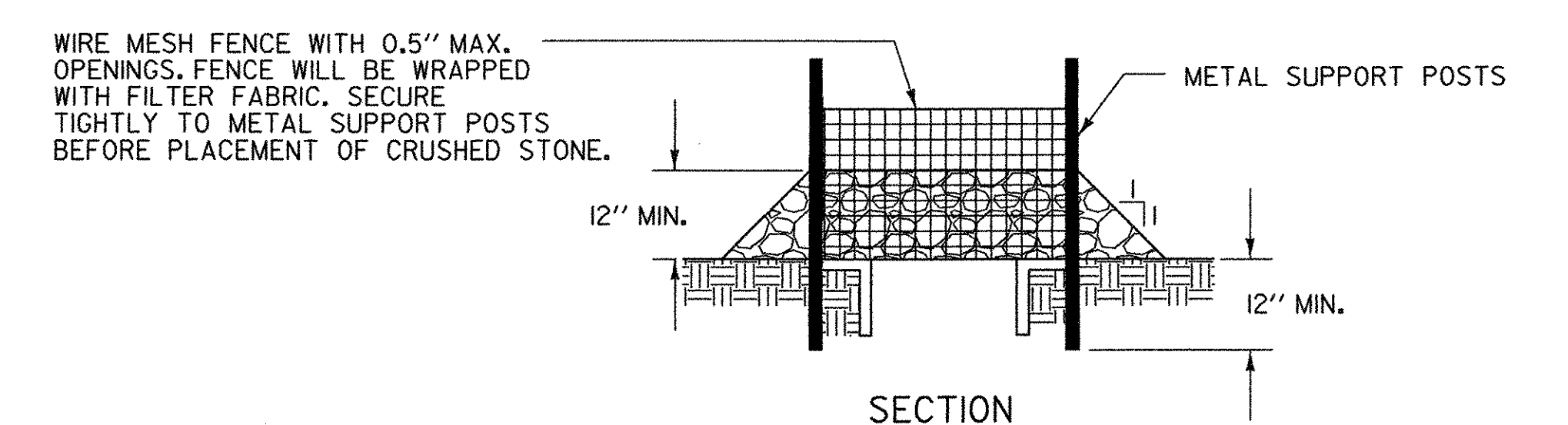
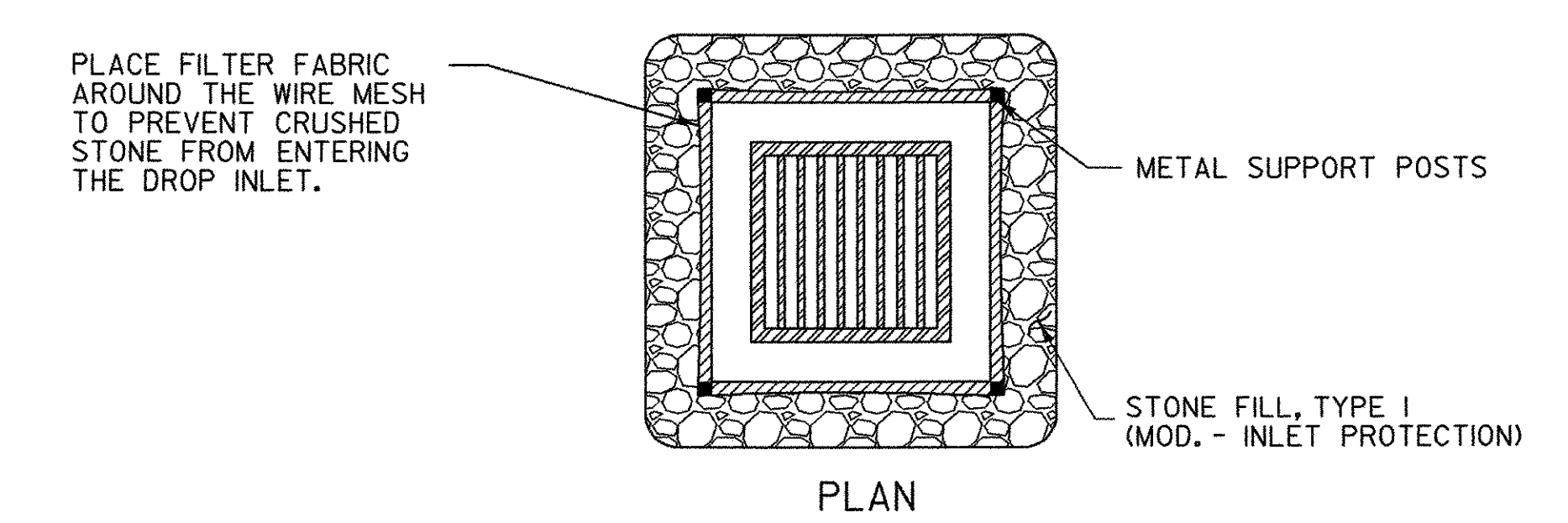
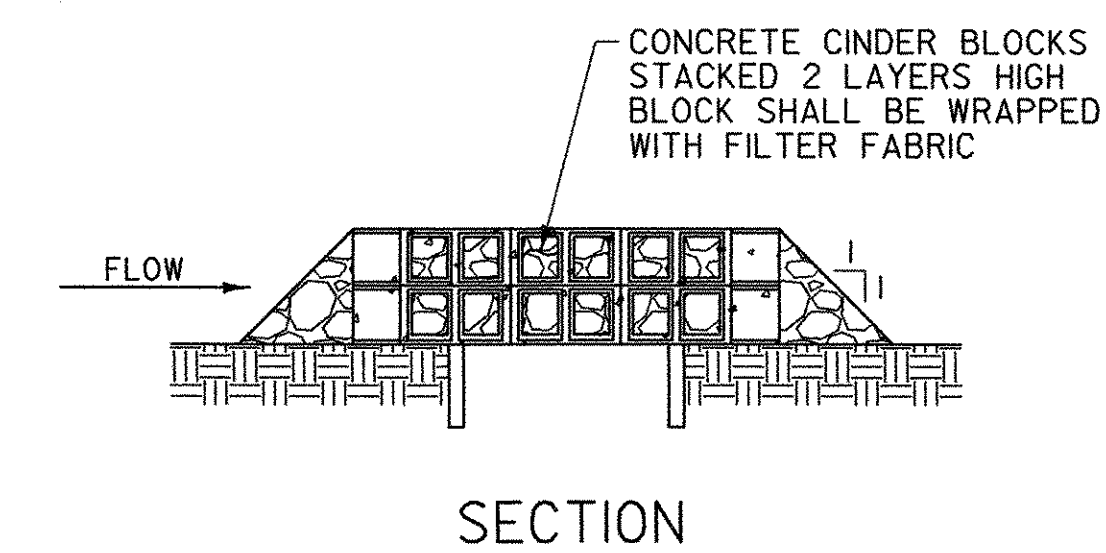

ROCK BARRIER INLET PROTECTION
TEMPORARY UNPAVED AREAS