

**TYPICAL BRIDGE SECTION**

SCALE 1/2" = 1'-0"

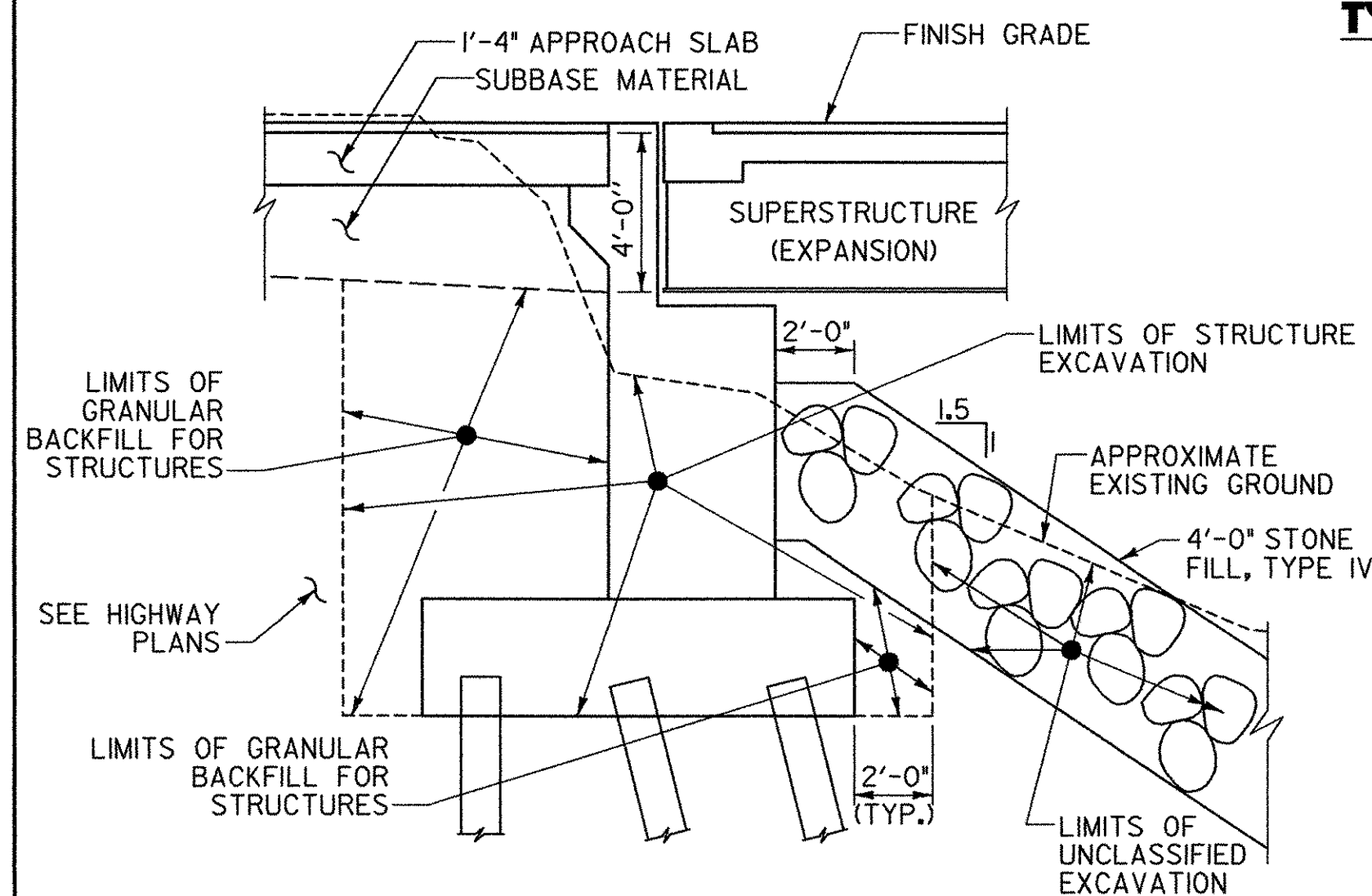

**TYPICAL ABUTMENT 1 SECTION**

NOT TO SCALE

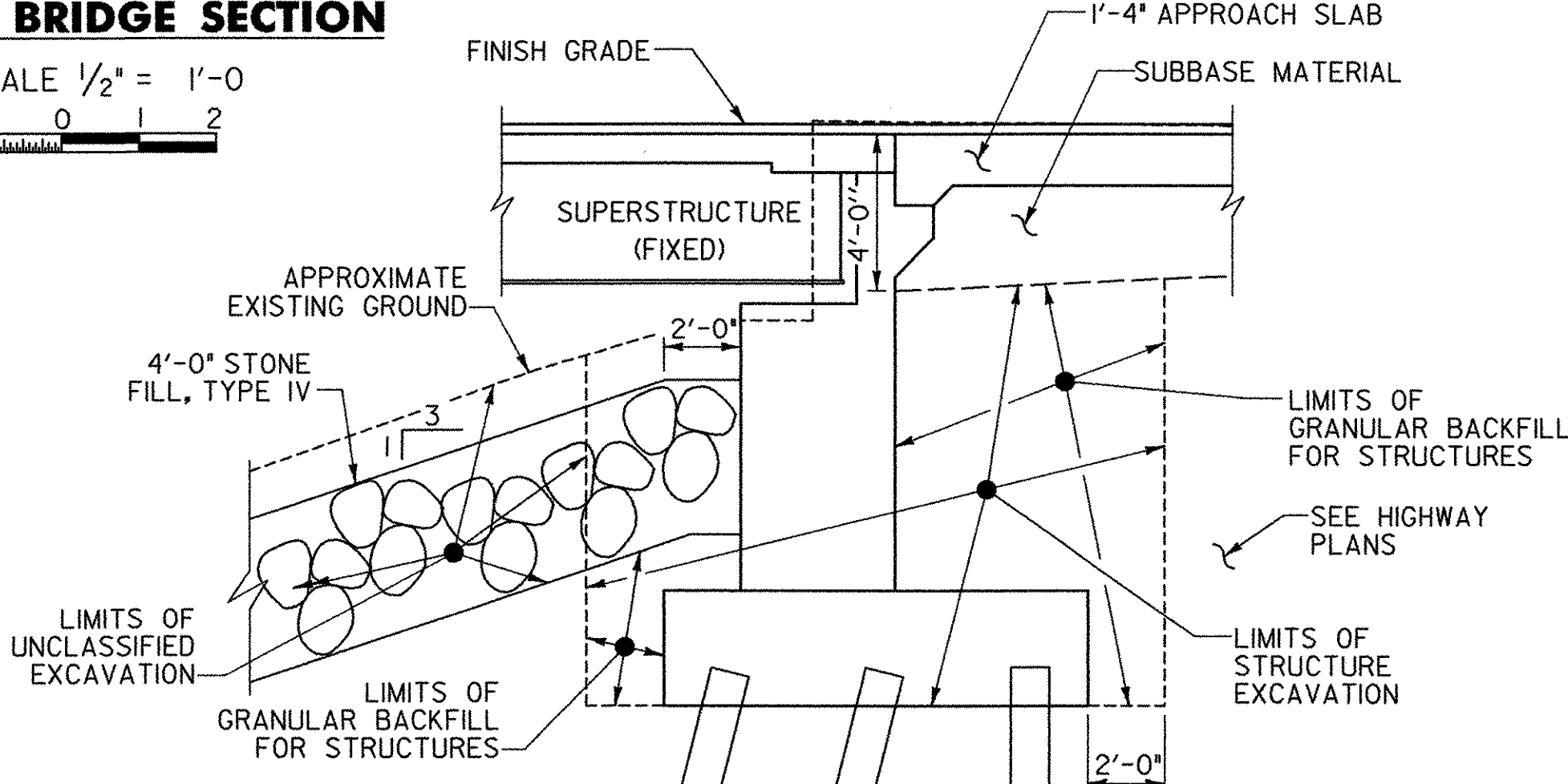

**TYPICAL ABUTMENT 2 SECTION**

NOT TO SCALE

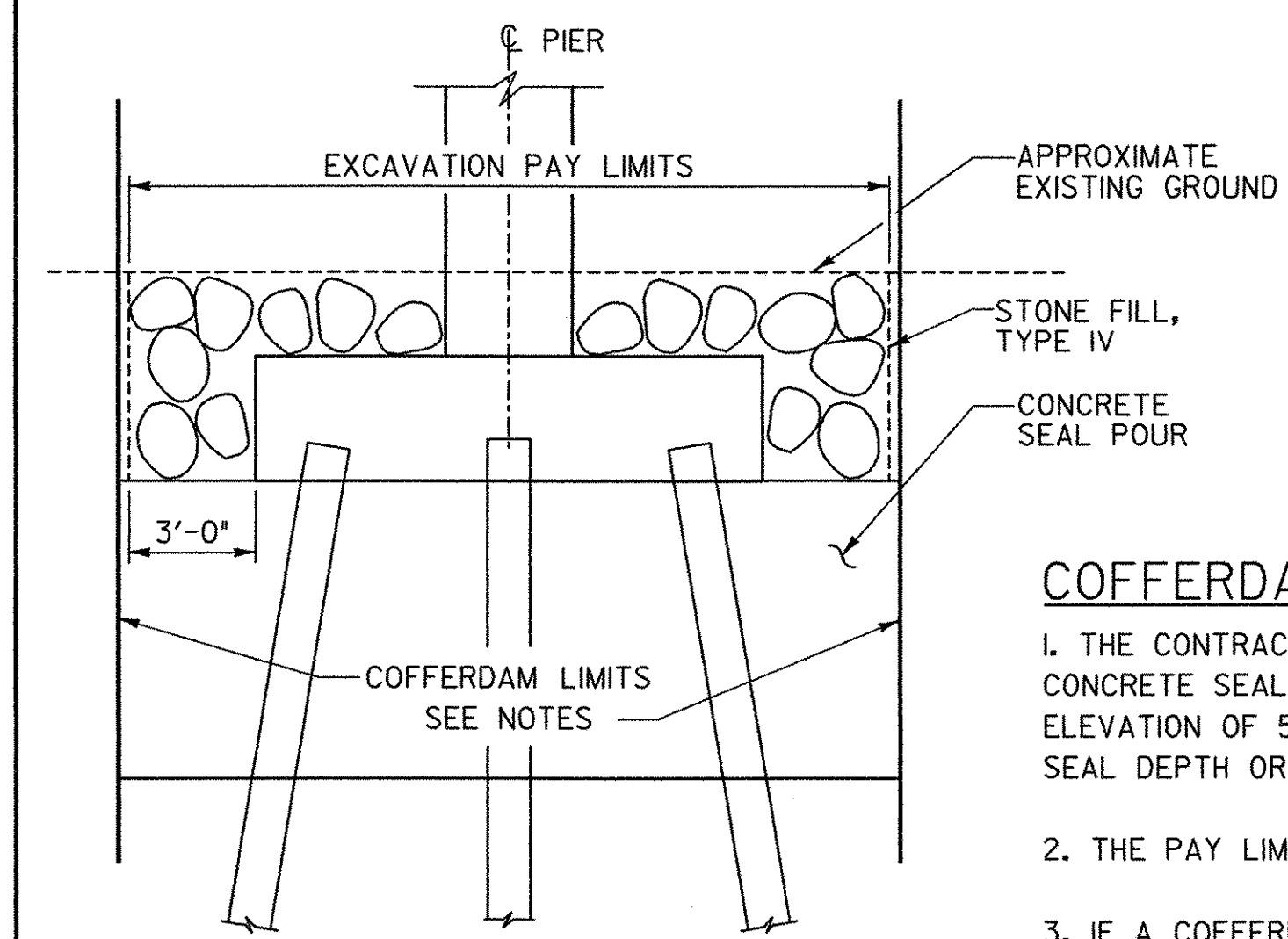

**TYPICAL PIER SECTION**

NOT TO SCALE

**COFFERDAM NOTES:**

- THE CONTRACTOR IS RESPONSIBLE FOR THE DESIGN OF THE COFFERDAM AND CONCRETE SEAL. THE PREDICTED SCOUR DEPTH IS BASED ON A BOTTOM OF SEAL ELEVATION OF 590.50. THE ENGINEER SHALL BE NOTIFIED OF ANY CHANGE IN THE FOUNDATION SEAL DEPTH OR SIZE. THESE CHANGES MAY IMPACT THE SIZE AND SPACING OF THE PILES.
- THE PAY LIMITS OF "COFFERDAM EXCAVATION, EARTH" AND COFFERDAM EXCAVATION, ROCK" SHALL BE 3'-0" OUTSIDE THE PERIMETER OF THE FOOTING.
- IF A COFFERDAM IS CONSTRUCTED WHICH IS LARGER THAN THE COFFERDAM EXCAVATION PAY LIMITS, PAYMENT FOR ALL UNCLASSIFIED CHANNEL EXCAVATION, INCLUDING THAT PORTION WHICH IS INSIDE THE COFFERDAM BUT OUTSIDE THE COFFERDAM EXCAVATION PAY LIMITS, WILL BE MADE AT THE CONTRACT UNIT PRICE FOR UNCLASSIFIED CHANNEL EXCAVATION.

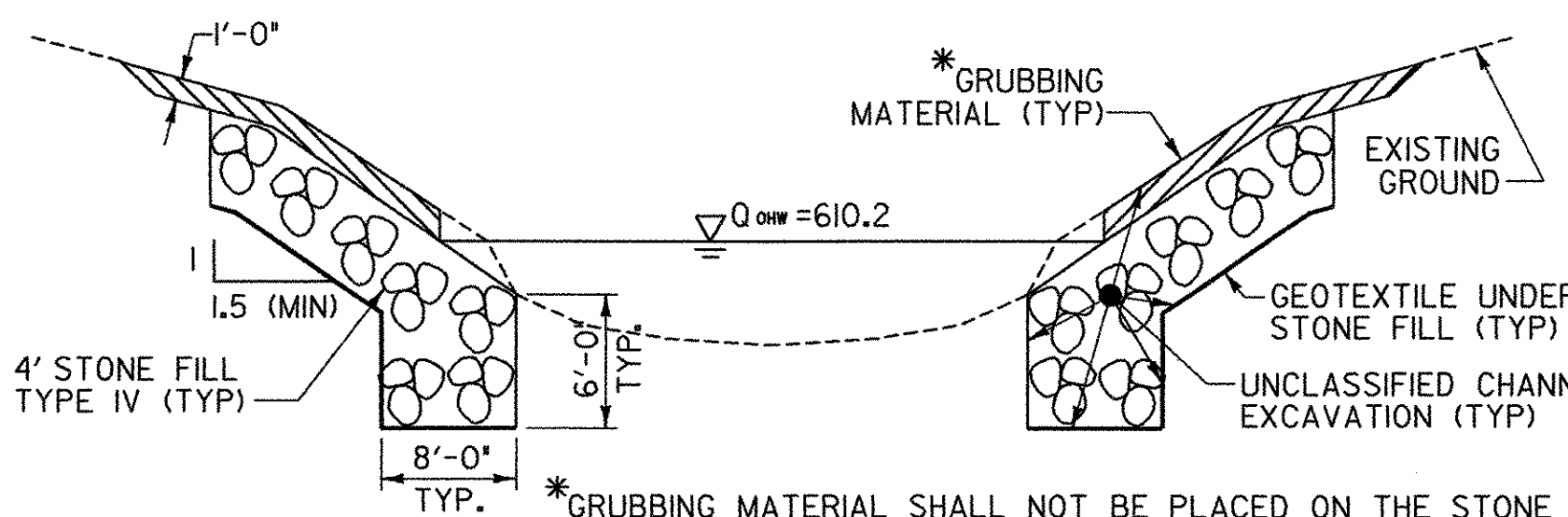

**TYPICAL CHANNEL SECTION**

NOT TO SCALE

**FINAL HYDRAULICS REPORT**

**HYDROLOGIC DATA**

DRAINAGE AREA= 44.91 square miles  
 CHARACTER OF TERRAIN: Predominantly mountainous woodland  
 CHARACTER & TYPE OF STREAM: Moderate slopes, natural channel, irregular side slopes  
 NATURE OF STREAMBED: Sand, gravel, cobbles

Q2.33= 1500 cfs      Q50= 5700 cfs  
 Q10= 3600 cfs      Q100= 6400 cfs  
 Q25= 4800 cfs      Q500= 8600 cfs

DATE OF FLOOD OF RECORD: Unknown  
 WATER SURFACE ELEV.: Unknown ESTIMATED DISCHARGE: Unknown  
 NATURAL STREAM VELOCITY @ Q25 = 6.65 fps  
 ICE CONDITIONS: Moderate DEBRIS: Moderate  
 DOES THE STREAM REACH MAXIMUM HIGHWATER ELEVATION RAPIDLY? Yes  
 IS ORDINARY RISE RAPID? No  
 IS STAGE AFFECTED BY UPSTREAM OR DOWNSTREAM CONDITIONS? No  
 IF YES, DESCRIBE.

WATERSHED STORAGE 4.0% HEADWATERS UNIFORM THROUGHOUT WATERSHED X  
 IMMEDIATELY ABOVE SITE

**EXISTING STRUCTURE**

STRUCTURE TYPE: Three-span Steel Girder Bridge with Reinforced Concrete Deck      YEAR BUILT: 1939  
 CLEAR SPAN (NORMAL TO STREAM): 103 feet  
 VERTICAL CLEARANCE ABOVE STREAMBED: 16.1 feet  
 WATERWAY OF FULL OPENING: 1600 square feet  
 DISPOSITION OF STRUCTURE: Remove  
 TYPE OF MATERIAL UNDER SUBSTRUCTURE: Unknown

WATER SURFACE ELEV. @ Q2.33= 612.64 ft VELOCITY= 4.8 fps  
 Q10= 616.02 ft " 6.8 fps  
 Q25= 617.51 ft " 7.5 fps  
 Q50= 618.50 ft " 8.0 fps  
 Q100= 619.23 ft " 8.3 fps

LONG TERM STREAM BED CHANGES: Long Term Profile Degradation

IS THE ROADWAY OVERTOPPED BELOW THE Q100? No FREQUENCY: N/A  
 RELIEF ELEVATION: N/A DISCHARGE OVER ROAD @ Q100: N/A

UPSTREAM STRUCTURE: TOWN: Huntington DISTANCE: 1.0 miles  
 HIGHWAY NO.: Town Highway No. 20 STRUCTURE NO.: Brq. No. 39  
 STRUCTURE TYPE: Single Span Steel Girder with Concrete Deck  
 CLEAR SPAN: 86' +/- CLEAR HEIGHT: 14' +/-  
 YEAR BUILT: 1980 FULL WATERWAY: UNKNOWN

DOWNSTREAM STRUCTURE: TOWN: Huntington DISTANCE: 0.45 miles  
 HIGHWAY NO.: Town Highway No. 3 STRUCTURE NO.: Brq. No. 11  
 STRUCTURE TYPE: Single Span Pony Truss  
 CLEAR SPAN: 110' +/- CLEAR HEIGHT: 13' +/-  
 YEAR BUILT: 2000 FULL WATERWAY: Unknown

**DESIGN CRITERIA:**

- DESIGN LIVE LOAD AASHTO HS-25
- DESIGN SPAN 90.75' + 90.75' = 181.5'
- ALLOWABLE LOAD FOR SPREAD FOOTINGS ON SOIL N/A ON LEDGE N/A
- ALLOWABLE LOAD FOR PILING 145 KIPS (ABUTMENTS), 195 KIPS (PIER) TYPE STEEL H-PILES ESTIMATED LENGTH 46' (ABUT. 1), 47' (ABUT. 2), 53' (PIER)
- STRUCTURAL STEEL AASHTO GRADE AASHTO M270 GRADE 50W
- REINFORCING STEEL GRADE 60  
 CONCRETE, HIGH PERFORMANCE CLASS A f<sub>c</sub>: 4000 PSI f<sub>t</sub>: 1600 psi  
 CONCRETE, HIGH PERFORMANCE CLASS B f<sub>c</sub>: 3500 PSI f<sub>t</sub>: 1400 psi

**TRAFFIC MAINTENANCE:**

- IS TRAFFIC TO BE MAINTAINED? YES IF YES, ON EXISTING STRUCTURE NO OR ON TEMPORARY BRIDGE YES
- TEMPORARY BRIDGE REQUIREMENTS: ONE OR TWO WAY ONE WAY TRAFFIC CONTROL SIGNALS REQUIRED YES  
 MINIMUM CLEAR SPAN (NORMAL TO STREAM) 92 feet MINIMUM CLEAR HEIGHT SEE TEMPORARY BRIDGE SKETCH  
 MINIMUM WATERWAY AREA 700 square feet  
 ARE SIDEWALKS REQUIRED? No IF SO, ON WHAT SIDE?  
 STRUCTURE TYPE

LOADING LEVELS (LOAD FACTOR)	LOAD FACTOR LOAD RATING (TONS)						
	H	HS	3S2	6 AXLE	3A. STR.	4A. STR.	5A. SEMI
INVENTORY A=2.17	48	55					
POSTED A=1.55	67	77	93		71	72	82
OPERATING A=1.30		91	111	133	84	85	

STRENGTH RF =  $\frac{0.85 M_N - 1.3 M_{DL}}{A \times M_{LL+I}}$

YEAR	TRAFFIC DATA				
	ADT	DHV	% D	% T	ADTT
2005	890	150	64	4	40
2025	1200	180	64	5	70

18 kip ESAL for flexible pavement from 2005 to 2025 = 155,000  
 18 kip ESAL for flexible pavement from 2005 to 2045 = 376,000  
 Design speed: 35

**PROPOSED STRUCTURE**

STRUCTURE TYPE: Two Span Curved Steel Girder w/Reinforced Conc. Deck  
 CLEAR SPAN (NORMAL TO STREAM): 125 ft  
 VERTICAL CLEARANCE ABOVE STREAMBED: 14.3 ft  
 WATERWAY OF FULL OPENING: 1300 sq. ft.

WATER SURFACE ELEV. @ Q2.33= 612.71 ft VELOCITY= 4.6 fps  
 Q10= 616.12 ft " 6.1 fps  
 Q25= 617.64 ft " 6.5 fps  
 Q50= 618.66 ft " 6.8 fps  
 Q100= 619.43 ft " 6.9 fps

IS THE ROADWAY OVERTOPPED BELOW THE Q100? No FREQUENCY: N/A  
 RELIEF ELEVATION: N/A DISCHARGE OVER ROAD @ Q100: N/A

AVERAGE LOW ELEVATION OF SUPERSTRUCTURE: 620.7 feet  
 VERTICAL CLEARANCE: @ FEMA Q25 = 3.1 feet

SCOUR: Predicted Q500 Pier Scour Prism extends down to EL. 578' (this includes 2 feet of predicted long term profile degradation and 27 feet of local pier scour.)  
 REQUIRED CHANNEL PROTECTION: Type IV, Stone Fill

**PERMIT INFORMATION**

AVERAGE DAILY FLOW: 165 cfs  
 ORDINARY LOW WATER: 45 cfs DEPTH: 1 foot  
 ORDINARY HIGH WATER: 620 cfs DEPTH: 3.8 feet (EL. 610.2')

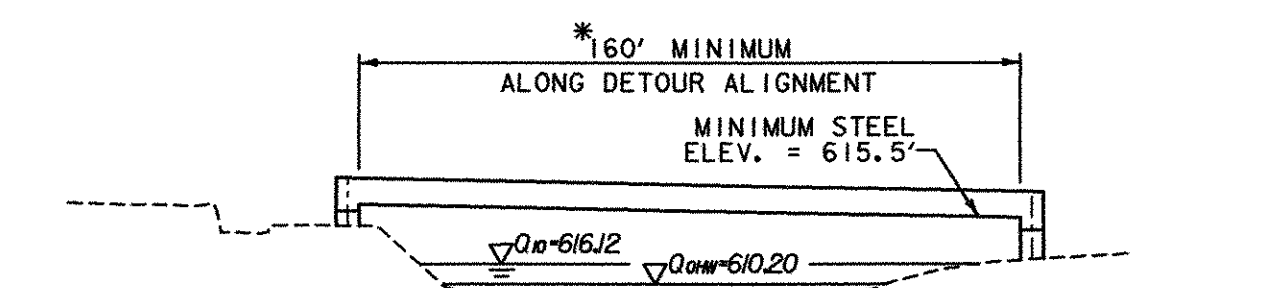

\* - CONTRACTOR SHALL HAVE THE OPTION OF CONSTRUCTING A SINGLE SPAN, TWO SPAN, OR THREE SPAN TEMPORARY BRIDGE. ANY PIERS SHALL BE LOCATED OUTSIDE OF THE LIMITS OF ORDINARY HIGH WATER.

DESIGN OF PIERS SHALL INCLUDE ICE LOADINGS AS FOLLOWS:  
 ICE THICKNESS = 2'  
 ICE PRESSURE = 250 PSI

**TEMPORARY BRIDGE REQUIREMENTS**

NTS

**STATE OF VERMONT AGENCY OF TRANSPORTATION**

Town Of HUNTINGTON Bridge No. 42  
 Highway No. T.H. 4 Log Sta. Surv. Sta.

EAST STREET (T.H. #4) OVER HUNTINGTON RIVER

**PRELIMINARY INFORMATION SHEET**

Designed By T. KNIGHT Drawn By D. HARRINGTON  
 Checked By Date Bridge Design Supervisor  
 M. CHENETTE 06/04 M. CHENETTE Date 09/05

PROJECT HUNTINGTON PROJECT NO. BRO 1445 (29)  
 DH Dgn.: ...\\Cadd\Trans\z01302pi.dgn Plot Date: 1/12/2006  
 Bridge Sheet No. Sheet 2 of 63