

NOTES

1. THE SUPERPAVE BITUMINOUS CONCRETE PAVEMENT WEARING COURSE ON THE ROADWAY SHALL BE TYPE III'S AND THE LEVELING COURSE SHALL BE TYPE IV'S, UNLESS OTHERWISE DIRECTED BY THE ENGINEER. THE TYPE IV'S LEVELING COURSE QUANTITY IS ESTIMATED AT 25 mm. THE 30 mm WEARING COURSE ON BRIDGE NO. 17 SHALL BE TYPE IV'S. ALL ASPHALT CEMENT USED IN THE SUPERPAVE BITUMINOUS CONCRETE PAVEMENT SHALL BE PG 58-34.
2. SUPERPAVE BITUMINOUS CONCRETE PAVEMENT TOLERANCE = ± 5 mm. (TOTAL THICKNESS EXCLUDING LEVELING)
3. GRASS GROWING ADJACENT TO PAVEMENT OR THROUGH CRACKS IN THE PAVEMENT WHICH MAY HAMPER THE PLACEMENT OF NEW BITUMINOUS CONCRETE SHALL BE REMOVED BY THE CONTRACTOR AS DIRECTED BY THE ENGINEER. PAYMENT FOR THIS WORK WILL NOT BE MADE DIRECTLY, BUT WILL BE CONSIDERED SUBSIDIARY TO ITEM 490.30 SUPERPAVE BITUMINOUS CONCRETE PAVEMENT.
4. THE COLD PLANING AND PAVING SHALL MATCH THE EXISTING CONDITIONS AT THE BEGINNING AND END OF THE PROJECT AS WELL AS ON THE TOWN HIGHWAYS BY THE USE OF A VERTICAL BUTT JOINT. SEE DETAIL ON SHEET 3.
5. EMULSIFIED ASPHALT TO BE APPLIED ON EXISTING PAVEMENT, BETWEEN ALL COURSES OF PAVEMENT AND ON COLD PLANED SURFACES, AT THE RATE OF 0.12 L/m² OR AS DIRECTED BY THE ENGINEER.
6. THE SURFACE OF THE EXISTING PARK AND RIDE SHALL BE PREPARED PRIOR TO PAVING. THERE IS AN ESTIMATED QUANTITY OF POWER GRADER RENTAL INCLUDED TO COVER THE COST OF THIS WORK.
7. EXISTING SHOULDER MATERIAL DEEMED UNSUITABLE BY THE RESIDENT ENGINEER, SHALL BE EXCAVATED TO A DEPTH OF 75 mm OR AS DIRECTED BY THE ENGINEER.

EXCAVATION WILL BE PAID FOR AS ALL PURPOSE EXCAVATOR OR GRADER RENTAL.

MATERIAL REMOVED SHALL BE REPLACED WITH SUBBASE OF CRUSHED GRAVEL (FINE GRADED) OR COLD PLANE GRINDINGS (402.12 MOD.) AS DIRECTED BY THE RESIDENT ENGINEER.

EXCAVATED MATERIAL SHALL BE SPREAD ON THE ADJACENT SLOPES OR REMOVED FROM PROJECT, AS DIRECTED BY THE ENGINEER.
8. ITEM 203.99 IS APPROPRIATE ONLY IN AREAS OF RETAINED GUARD RAIL.
9. COLD PLANE GRINDINGS SHALL REMAIN THE PROPERTY OF THE STATE OF VERMONT AND SHALL BE USED INSTEAD OF AGGREGATE SHOULDERS TO BACK UP THE NEW PAVEMENT OVERLAY AND TO BACK UP GUARD RAIL IN ALL GUARD RAIL AREAS AS DIRECTED BY THE RESIDENT ENGINEER. THIS WILL BE PAID UNDER ITEM 402.12 (MOD.)
10. AN ESTIMATED QUANTITY OF EARTH BORROW HAS BEEN INCLUDED FOR THE PROVISION OF CONSTRUCTING GUARD RAIL TERMINAL FLARES WHICH SHALL BE CAPPED WITH AN ESTIMATED 75 mm DEPTH OF AGGREGATE SHOULDER MATERIAL AS DIRECTED BY THE RESIDENT ENGINEER. THE QUANTITIES INCLUDED REFLECT 20 CUBIC METERS OF EARTH BORROW AND 5 TONS OF AGGREGATE SHOULDER MATERIAL FOR EACH GUARD RAIL TERMINAL, ALTHOUGH THERE APPEARS TO BE EXCESS MATERIAL AVAILABLE FROM DITCHING WHICH CAN BE USED TO CONSTRUCT THE TERMINAL FLARES.
11. ITEM 616.47, BITUMINOUS CONCRETE GUTTERS AND TRAFFIC ISLANDS WILL BE PAID ONLY WHERE SPECIFIED IN THE ITEM DETAIL SUMMARY SHEET. ALL OTHER BITUMINOUS CONCRETE PAVEMENT WORK, WHICH COULD INVOLVE SOME HAND-WORK (SUCH AS DRIVES AND AROUND DRAINAGE/UTILITY STRUCTURES) SHALL BE PAID FOR AT THE CONTRACT UNIT PRICE FOR ITEM 490.30 SUPERPAVE BITUMINOUS CONCRETE PAVEMENT.

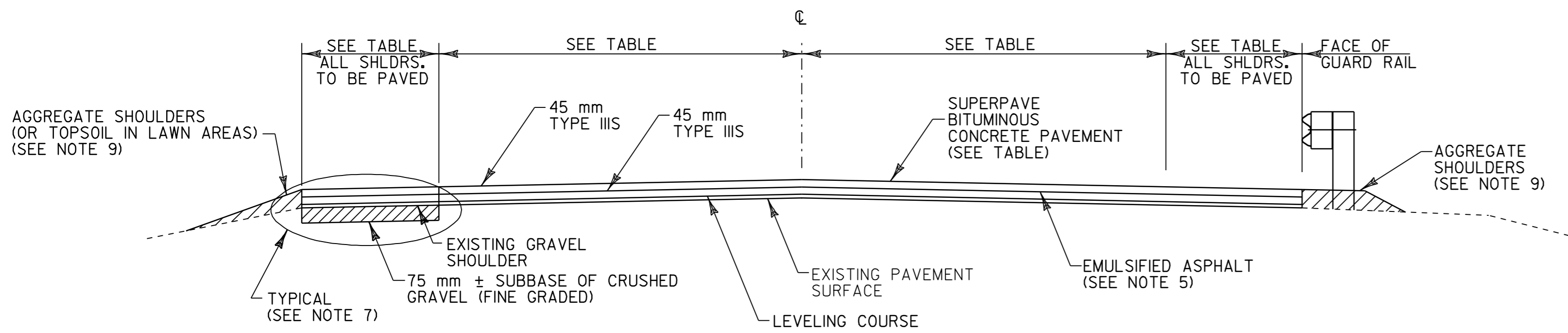

OVERLAY TYPICAL SECTION - ROADWAY

UNDERHILL STA. 7+056.97 TO STA. 7+956.60
 WESTFORD STA. 0+000.00 TO STA. 0+782.0
 WESTFORD STA. 0+789.6 TO STA. 4+541.57
 CAMBRIDGE STA. 0+000.00 TO STA. 3+444.00

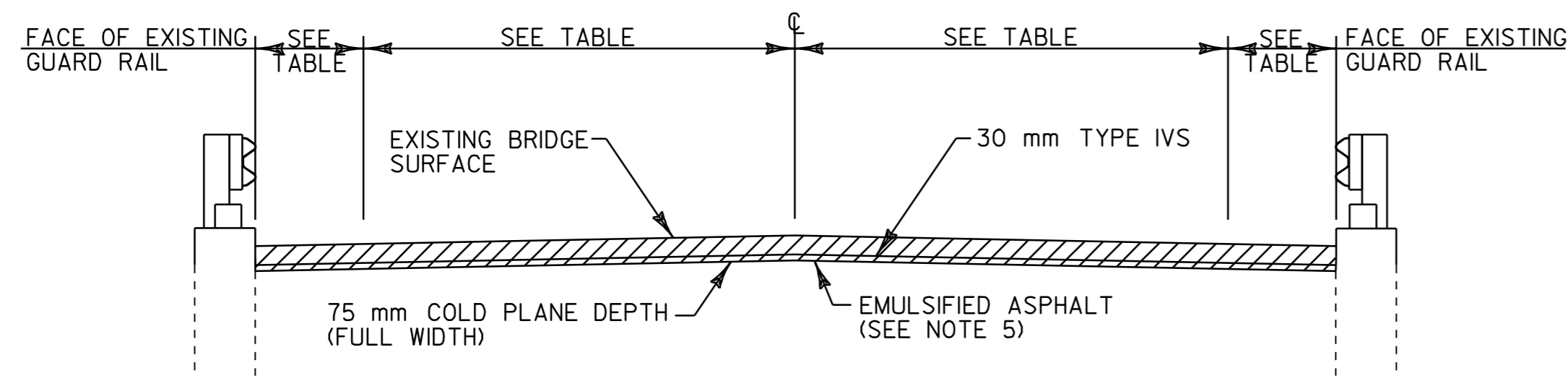

COLD PLANE TYPICAL SECTION - BRIDGE NO. 17

VT ROUTE 15

BRIDGE NO. 17 - WESTFORD STA. 0+782.0 TO 0+789.6

NOTE: 1) ALL DIMENSIONS IN MILLIMETERS EXCEPT WHERE OTHERWISE INDICATED.

RURAL AREAS - SEED MIXTURE

% WT	KG/HA	NAME	PUR %	GERM %
37.1	26.0	CREeping RED FESCUE	98	85
37.1	26.0	TALL FESCUE	95	90
5.7	4.0	RED TOP	95	90
14.4	10.0	BIRDFOOT TREFoil	98	85
5.7	4.0	ANNUAL RYE GRASS	95	85
100.0	70.0			

SEED MIXTURE:
 SHALL NOT HAVE A WEED CONTENT EXCEEDING 0.40% BY WEIGHT AND SHALL BE FREE OF ALL NOXIOUS SEED.

SEED:
 TO BE APPLIED PER SEEDING FORMULAS OR AS DIRECTED BY THE ENGINEER.

FERTILIZER:
 FORMULA 10-20-10, TO BE USED WITH SEED, APPLIED AT THE RATE OF 560 KG/HA. (HYDRO SEEDERS MAY USE 19-19-19 FORMULA.)

AGRICULTURAL LIMESTONE:
 TO BE APPLIED AT THE RATE OF 4500 KG/HA, OR AS DIRECTED BY THE ENGINEER.

HAY MULCH:
 TO BE PLACED ON EARTH SLOPES AT THE RATE OF 4500 KG/HA, OR AS DIRECTED BY THE ENGINEER.

TOPSOIL:
 TO BE USED AS INDICATED ON THE PLANS, OR AS DIRECTED BY THE ENGINEER.

PROJECT PAVING LIMITS

TOWN & ROUTE	BEGIN STATION	END STATION	LANE TYPICAL	WEARING DEPTH	LEVELING TONS	NOTES
UNDERHILL, VT ROUTE 15	7+056.97	7+956.6	1.2 M - 3.3 M - 3.3 M - 1.2 M	45 mm	480	LEVEL, THEN OVERLAY WITH TWO 45 mm LIFTS OF TYPE III'S
WESTFORD, VT ROUTE 15	0+000.0	0+578.0	1.2 M - 3.3 M - 3.3 M - 1.2 M	45 mm	308	LEVEL, THEN OVERLAY WITH TWO 45 mm LIFTS OF TYPE III'S
WESTFORD, VT ROUTE 15	0+578.0	0+638.0	VARIABLES - SEE LAYOUT SHEETS	45 mm	37	LEVEL, THEN OVERLAY WITH TWO 45 mm LIFTS OF TYPE III'S
WESTFORD, VT ROUTE 15	0+638.0	0+763.0	3.9 M - 3.3 M - 3.3 M - 1.5 M	45 mm	89	LEVEL, THEN OVERLAY WITH TWO 45 mm LIFTS OF TYPE III'S
WESTFORD, VT ROUTE 15	0+763.0	0+782.0	VARIABLES - SEE LAYOUT SHEETS	45 mm	11	LEVEL, THEN OVERLAY WITH TWO 45 mm LIFTS OF TYPE III'S
WESTFORD, VT ROUTE 15	0+782.0	0+789.6	1.2 M - 3.3 M - 3.3 M - 1.2 M	30 mm	-	BRIDGE NO. 17; COLD PLANE 75 mm, THEN OVERLAY WITH 30 mm TYPE IV
WESTFORD, VT ROUTE 15	0+789.6	4+250.0	1.2 M - 3.3 M - 3.3 M - 1.2 M	45 mm	1859	LEVEL, THEN OVERLAY WITH TWO 45 mm LIFTS OF TYPE III'S
WESTFORD, VT ROUTE 15	4+250.0	4+541.57	2.7 M - 3.3 M - 3.3 M - 1.2 M	45 mm	181	LEVEL, THEN OVERLAY WITH TWO 45 mm LIFTS OF TYPE III'S
CAMBRIDGE, VT ROUTE 15	0+000.0	0+320.0	2.7 M - 3.3 M - 3.3 M - 1.2 M	45 mm	185	LEVEL, THEN OVERLAY WITH TWO 45 mm LIFTS OF TYPE III'S
CAMBRIDGE, VT ROUTE 15	0+320.0	2+922.0	1.2 M - 3.3 M - 3.3 M - 1.2 M	45 mm	1482	LEVEL, THEN OVERLAY WITH TWO 45 mm LIFTS OF TYPE III'S
CAMBRIDGE, VT ROUTE 15	2+922.0	3+096.0	VARIABLES - SEE LAYOUT SHEETS	45 mm	121	LEVEL, THEN OVERLAY WITH TWO 45 mm LIFTS OF TYPE III'S
CAMBRIDGE, VT ROUTE 15	3+096.0	3+444.0	1.2 M - 3.3 M - 3.3 M - 1.2 M	45 mm	186	LEVEL, THEN OVERLAY WITH TWO 45 mm LIFTS OF TYPE III'S

PROJECT TYPICALS & PAVING LIMITS

PROJECT NAME: UNDERHILL - CAMBRIDGE	PLOT DATE: 26-JAN-2006 11:00
PROJECT NUMBER: SIP 2212(1)S	DRAWN BY: D-H
FILE NAME: /pave/99b176/pbl76.dgn	CHECKED BY:
PROJECT LEADER: JLL	SHEET 2 OF 36
DESIGNED BY: D-H	
IPARM FILE NAME: pbl76ty1	

ARCHIVED IN DPR

