

SECTION A-A FOR 5 T.S. PER LEVEL
SCALE 1:20

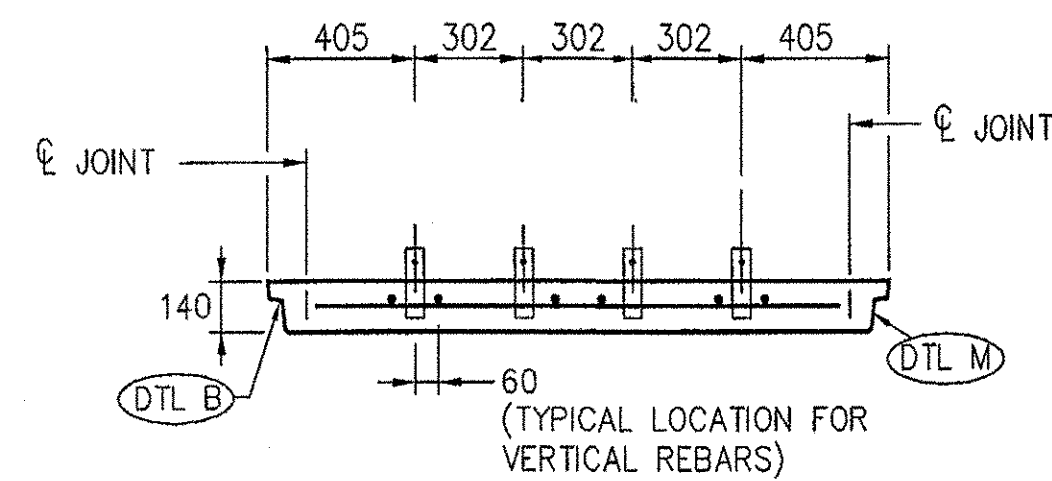

SECTION A-A FOR 4 T.S. PER LEVEL
SCALE 1:20

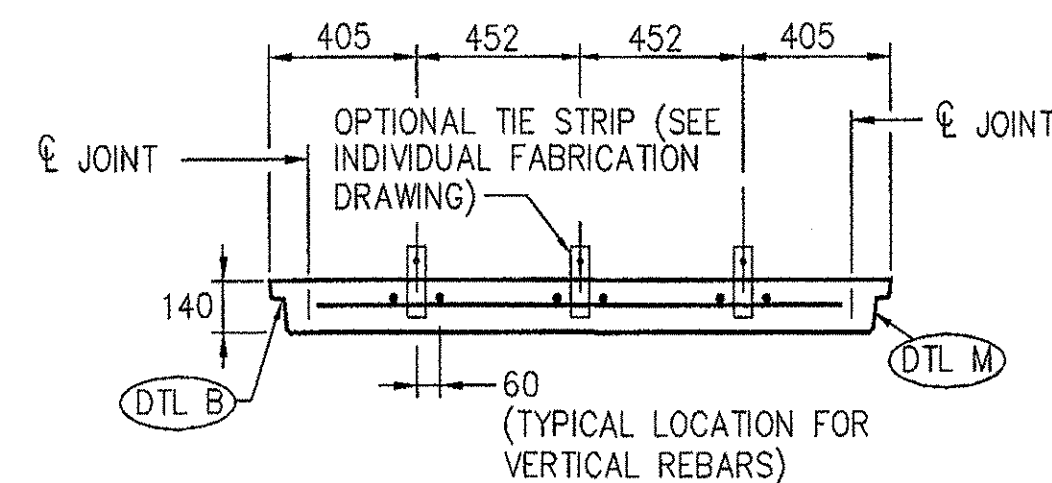

SECTION A-A FOR 2 OR 3 T.S. PER LEVEL
SCALE 1:20

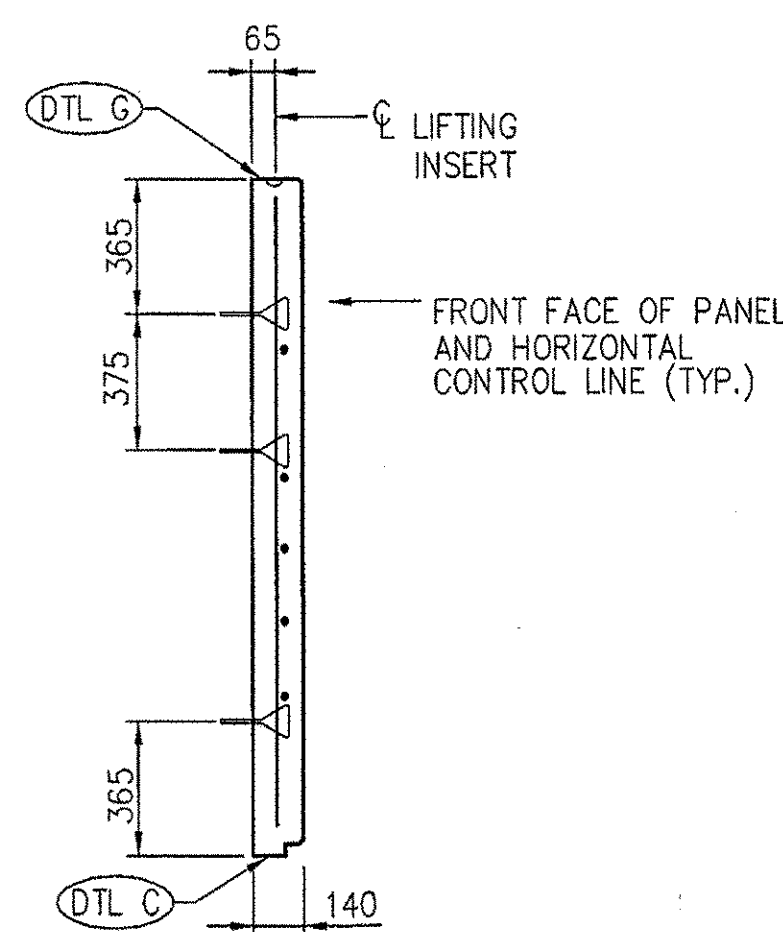

SECTION J-J
SCALE 1:20

SEE INDIVIDUAL FABRICATION DRAWING FOR PLACEMENT OF REBARS.

ALL DIMENSIONS ARE IN MILLIMETERS UNLESS OTHERWISE NOTED

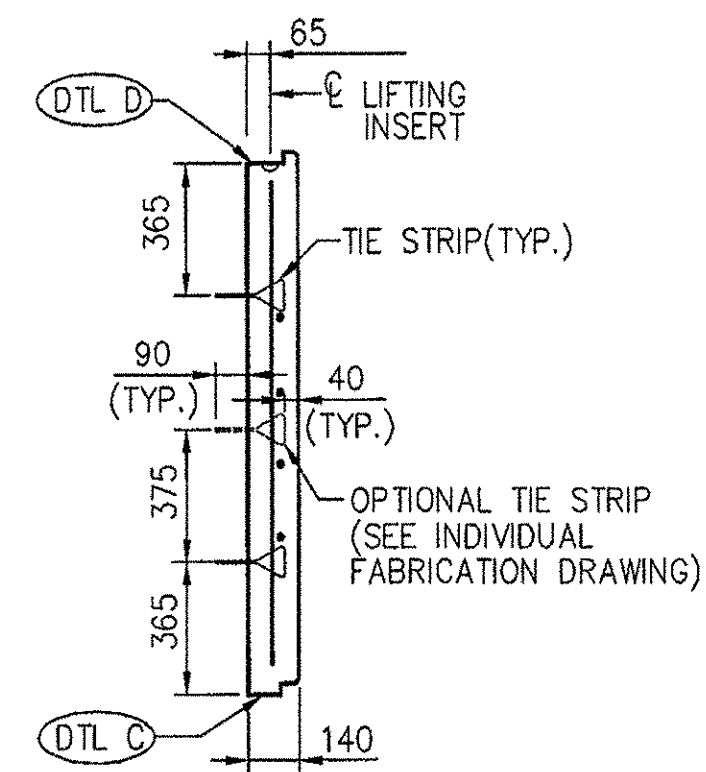

SECTION B-B SECTION C-C
SCALE 1:20

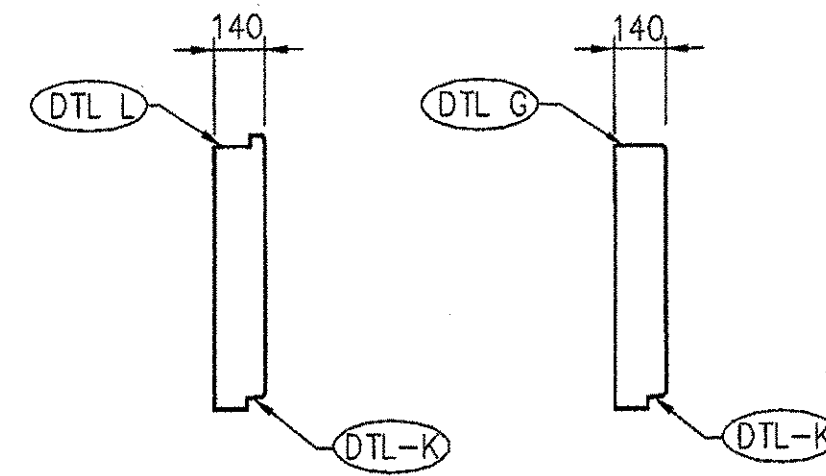

SECTION D-D SECTION E-E
SCALE 1:20

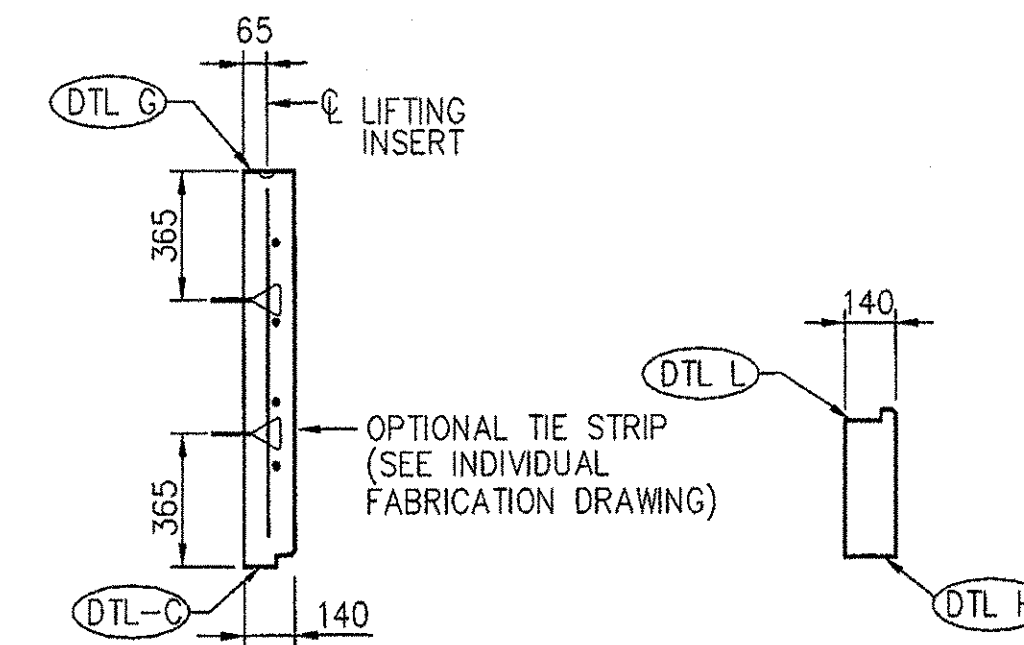

SECTION F-F
SCALE 1:20

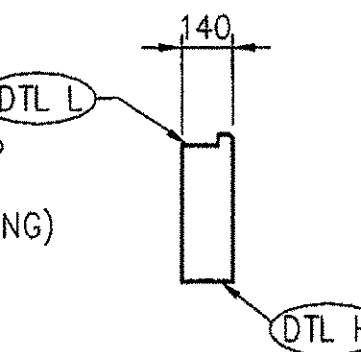

SECTION G-G
SCALE 1:20

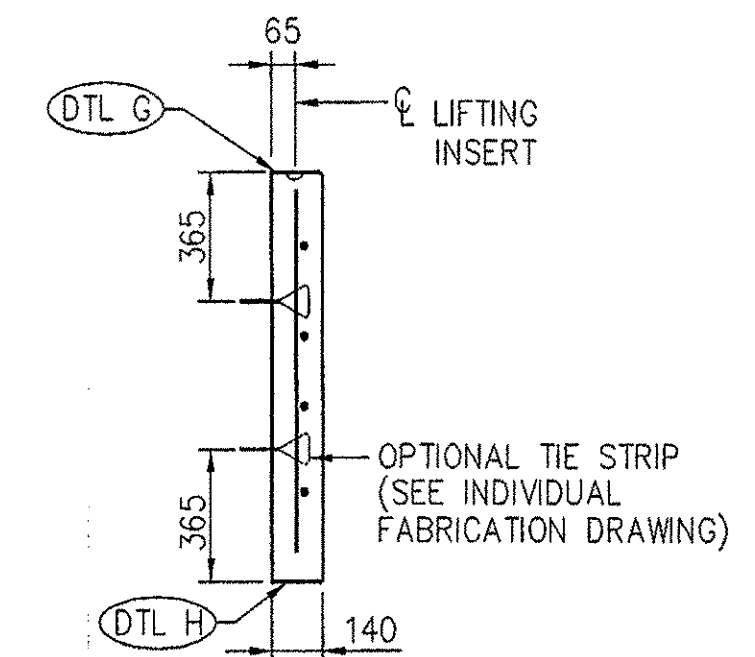

SECTION H-H
SCALE 1:20

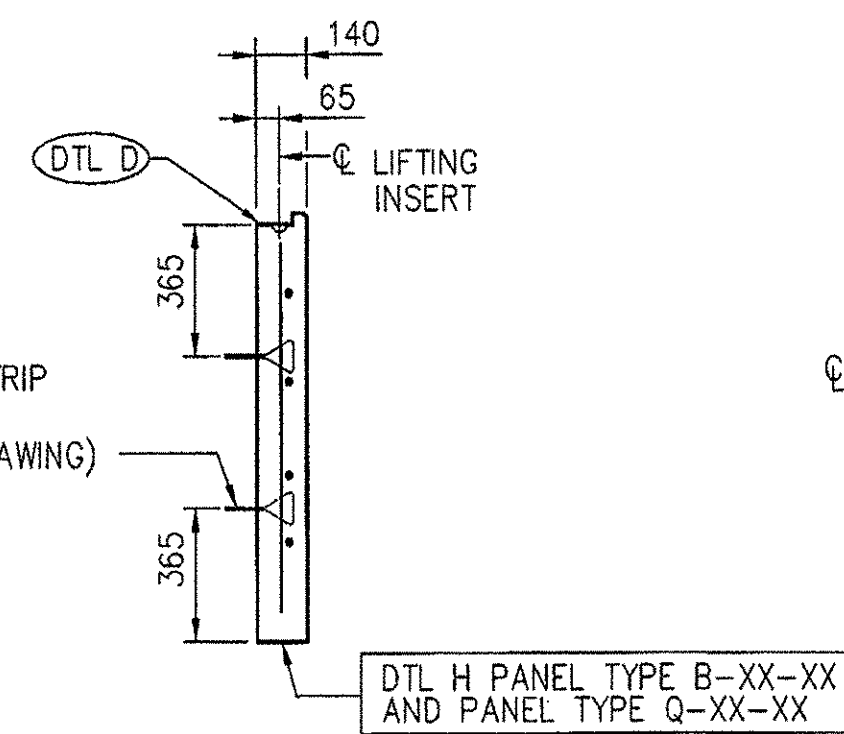

SECTION K-K
SCALE 1:20

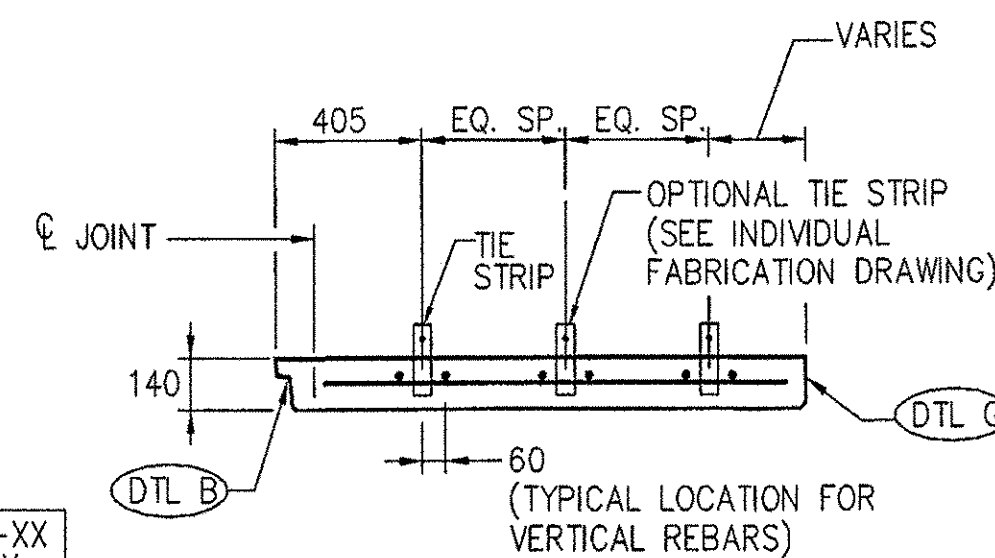

SECTION L-L
SCALE 1:20

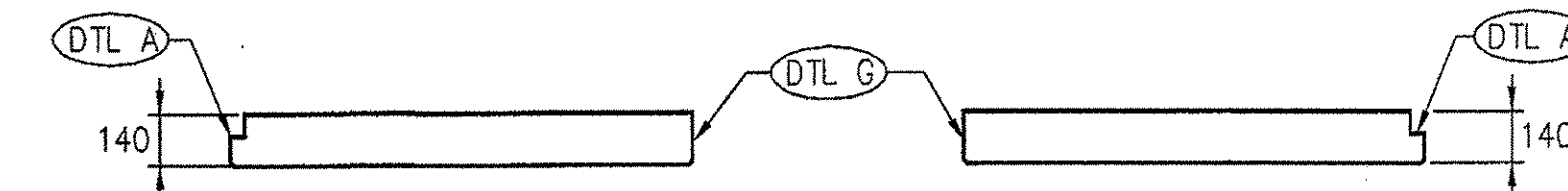

SECTION M-M
SCALE 1:20

SECTION P-P
SCALE 1:20

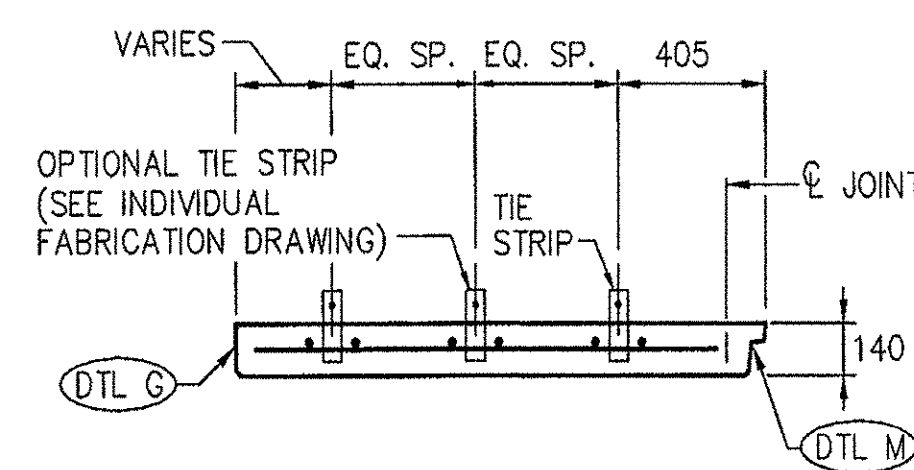

SECTION R-R
SCALE 1:20

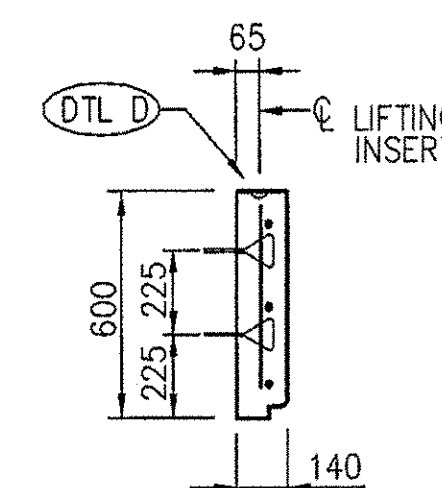

SECTION S-S
SCALE 1:20

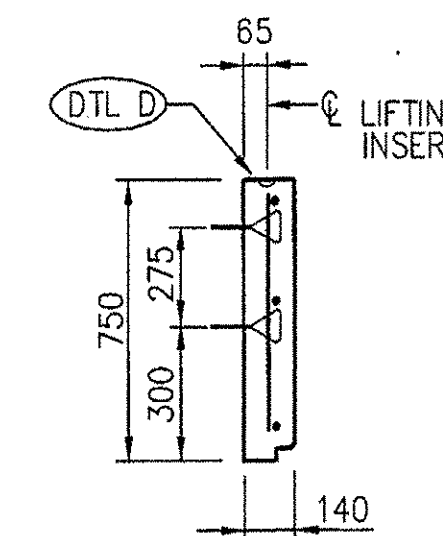

SECTION T-T
SCALE 1:20

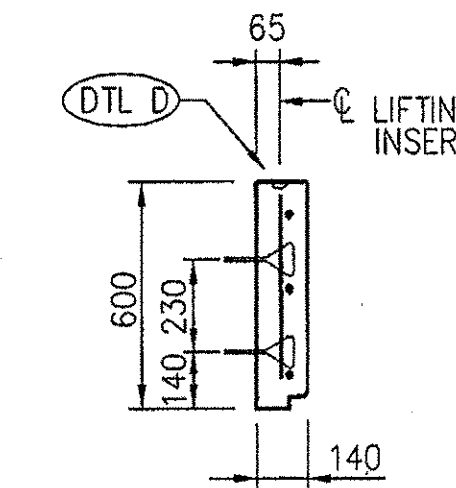

SECTION U-U
SCALE 1:20

RECEIVED
OK'D BY: _____ OK'D BY: LAGS
AUG 15 2002
SUBMITTED: _____ APPROVED: _____
BY: CPW DATE: 6/15/02

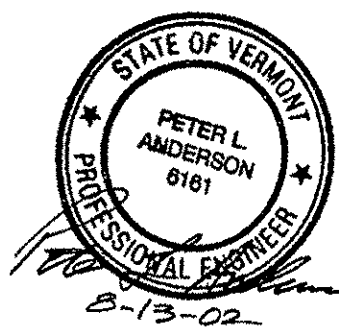

C:\15765\FINAL_SHOPS\15765_S02.DWG

This drawing contains information proprietary to The Reinforced Earth Company, and is being furnished for the use of VT AOT only in connection with this project; and the information contained herein is not to be transmitted to any other organization unless specifically authorized in writing by The Reinforced Earth Company. The Reinforced Earth Company is exclusive licensee in the United States under patents issued to Henri Vidal, and the furnishing of this drawing does not constitute an expressed or implied license under the Vidal patents.

The design contained on these drawings is based on information provided by the owner. On the basis of this information, The Reinforced Earth Company has designed, and is responsible for the internal stability of the structure only. External stability, including foundation and slope stability, is the responsibility of the owner.

The Reinforced Earth Company
8614 Westwood Center Drive Suite 1100, Vienna, Virginia 22182 (703) 821-1175

"REINFORCED EARTH" is the registered trademark of The Reinforced Earth Company.

DESIGNED BY: KPB		PROJECT NAME US ROUTE 5 - BARTON PN STP 0113(58)S	DATE 6-11-02
PROJECT ENGR: KPB		LOCATION COUNTY OF ORLEANS VERMONT	CONTRACT NO. 15765
CHECKED BY: PLA		OWNER VT AOT	DRAWING NO. S2 OF S9
ENG. MANAGER REV.	DATE	DESCRIPTION	SCALE AS SHOWN
		DRAWING COVERS PANEL CASTING DETAILS	