

S2-1

SIGN	DIMENSIONS (INCHES)										
	A	B	C	D	E	F	G	H	J	K	L
MIN./STD.	30	1/2	3/4	1 1/4	16 1/2	6	6 1/2	1 7/8	5 3/4	4	12
EXPWY.	36	5/8	7/8	1 1/2	19 3/4	7 1/4	7 1/8	2 1/4	6 7/8	4 3/4	14 3/8
SPECIAL	48	3/4	1 1/4	2	26 1/2	9 1/2	10 3/8	3	9 1/4	6 1/2	19 1/4

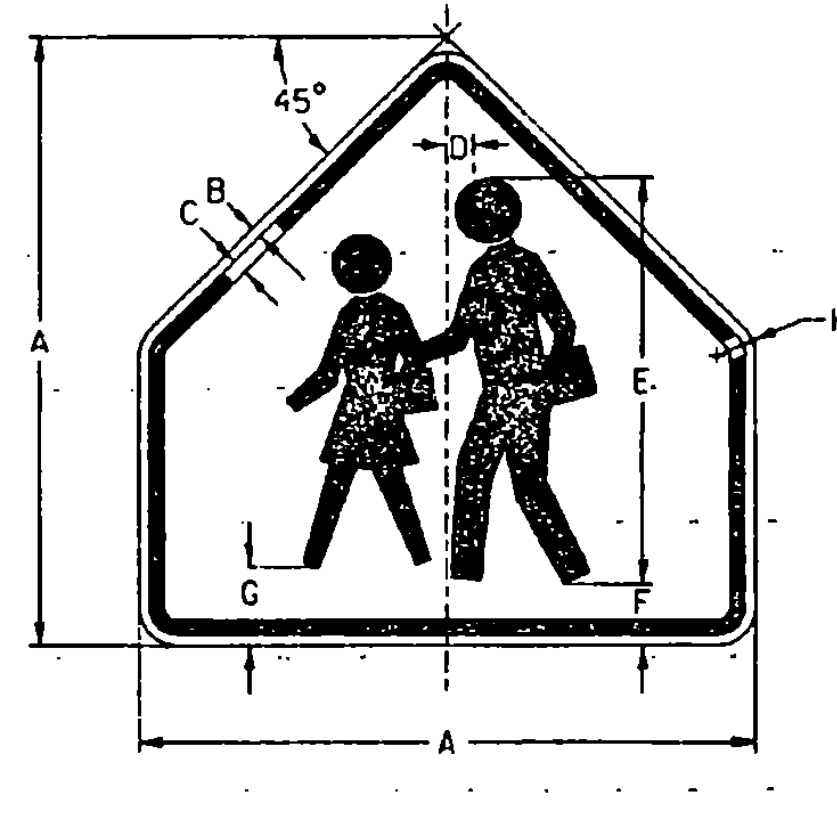

S1-1

SIGN	DIMENSIONS (INCHES)						
	A	B	C	D	E	F	H
MIN./STD.	30	1/2	3/4	2	20	3	3 3/4
EXPWY.	36	5/8	7/8	2 1/2	24	3 1/2	4 1/2
SPECIAL	48	3/4	1 1/4	3 1/4	32	5	6

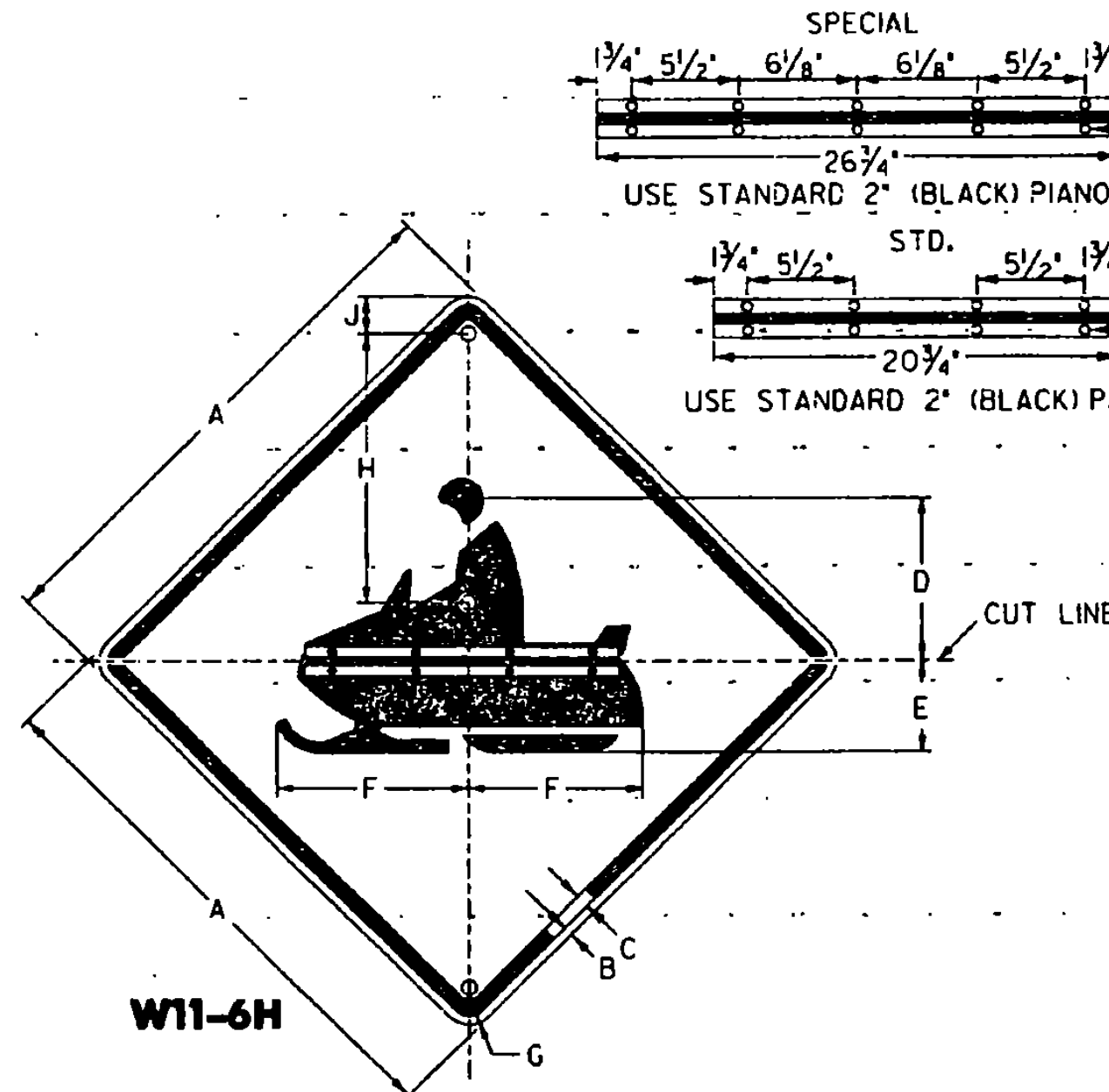

W11-6H

SIGN	DIMENSIONS (INCHES)									
	A	B	C	D	E	F	G	H	J	
STD.	30	1/2	3/4	1 1/8	5 1/8	12 1/8	1 7/8	14	2 1/2	
SPECIAL	36	5/8	7/8	1 1/2	6 3/8	15 1/4	2 1/4	19	2 1/2	

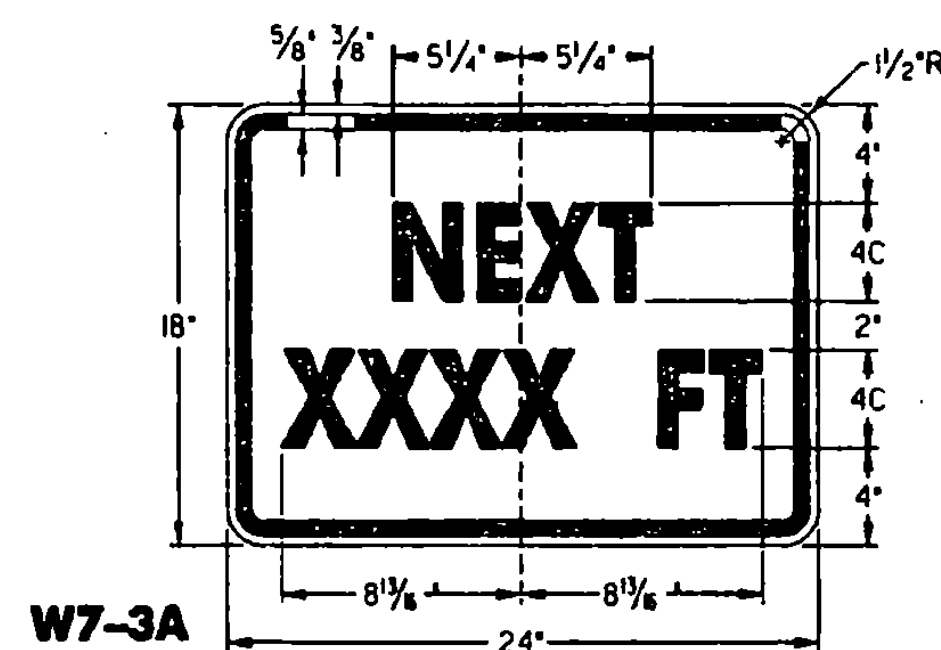
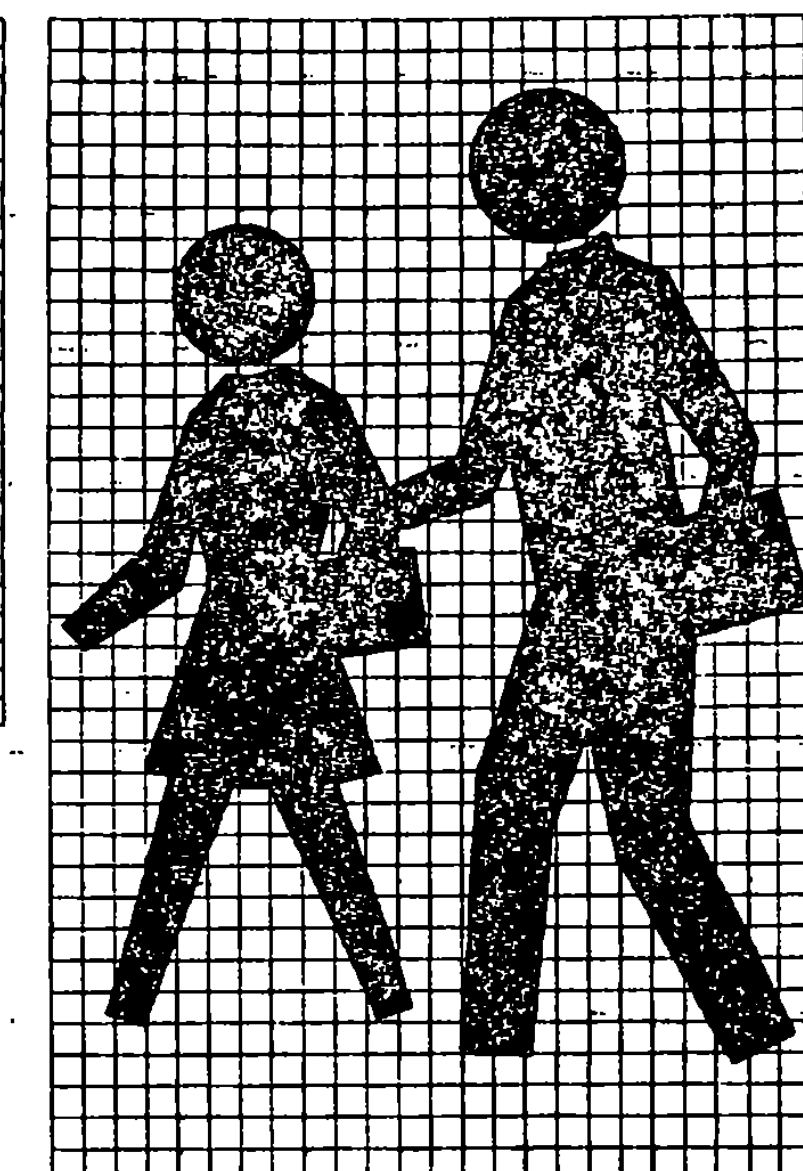
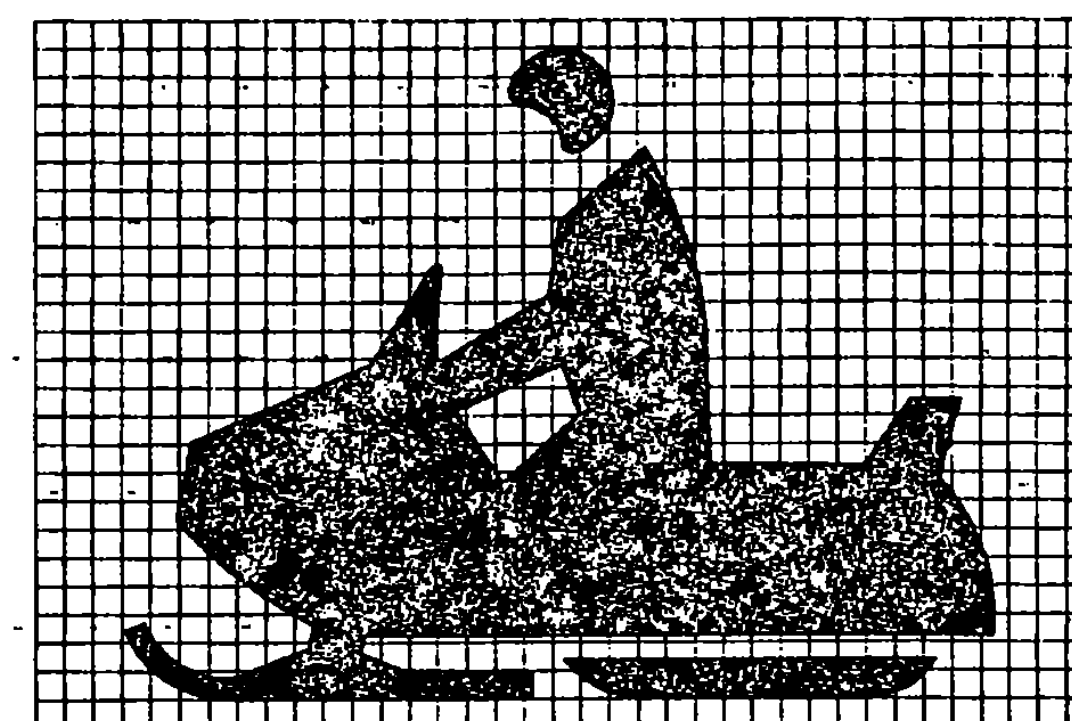

W7-3A

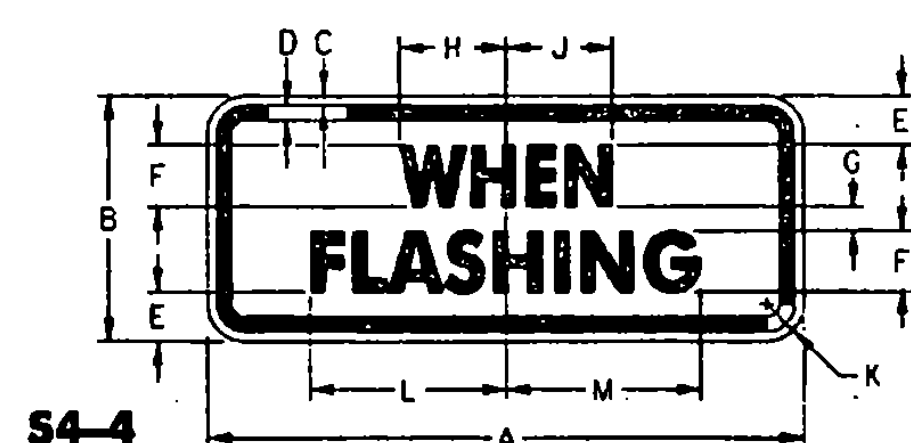

S4-4

SIGN	DIMENSIONS (INCHES)												
	A	B	C	D	E	F	G	H	J	K	L	M	
MIN./STD.	24	10	3/8	5/8	2	2 1/2	1	4 3/8	4 1/4	1 1/2	7 5/8	8 1/8	
EXPWY.	36	15	5/8	7/8	2 3/4	4	1 1/2	6 1/8	6 1/4	2 1/4	12 3/8	12 1/8	
SPECIAL	48	20	3/4	1 1/4	4	5	2	8 3/4	8 1/2	3	15 1/4	16 1/8	

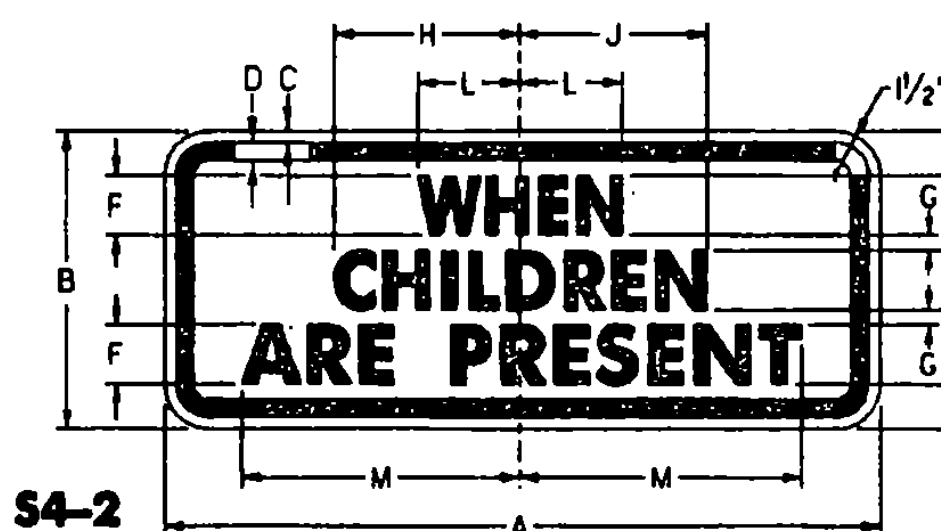

S4-2

SIGN	DIMENSIONS (INCHES)												
	A	B	C	D	E	F	G	H	J	K	L	M	
MIN./STD.	24	10	3/8	5/8	1 1/2	2	3 1/2	3 3/8	1 1/2	6 1/4	9 5/8		
EXPWY.	36	15	5/8	7/8	2 1/4	3	4 3/8	4 3/8	2 1/4	9 3/8	14		
SPECIAL	48	20	3/4	1 1/4	3	4	5 1/8	5 1/8	3	12 1/2	18 5/8		

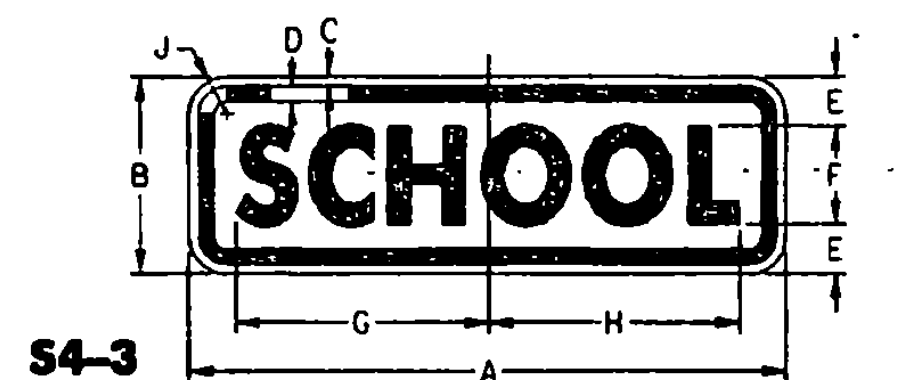

S4-3

SIGN	DIMENSIONS (INCHES)								
	A	B	C	D	E	F	G	H	J
MIN./STD.	24	8	3/8	5/8	2	4	10	10 1/4	1 1/2
EXPWY.	36	12	5/8	7/8	3	6	15	15 3/8	2 1/4
SPECIAL	48	16	3/4	1 1/4	4	8	20	20 1/2	3

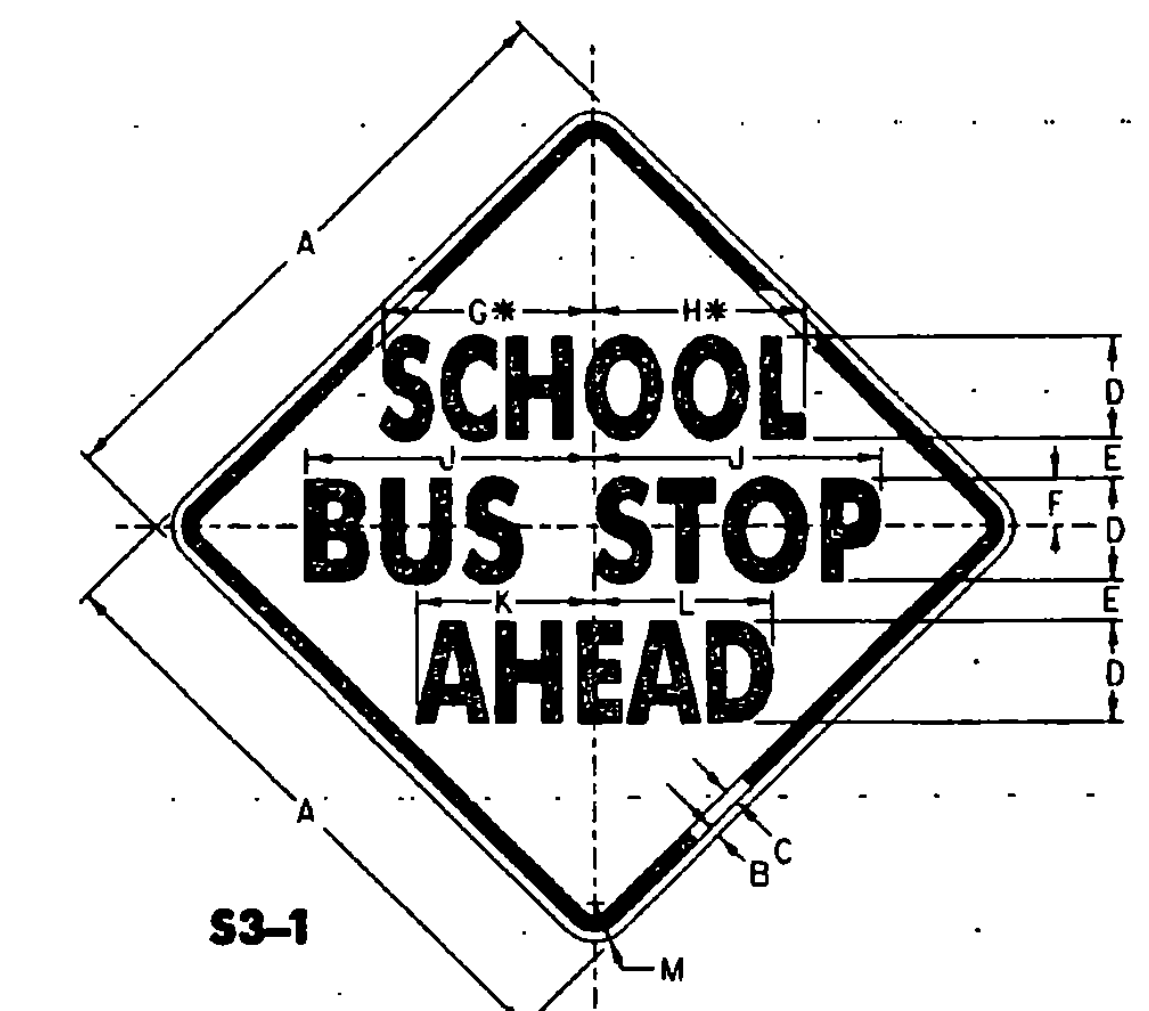

S3-1

SIGN	DIMENSIONS (INCHES)												
	A	B	C	D	E	F	G	H	J	K	L	M	
MIN./STD.	30	1/2	3/4	5C	2	2 1/2	10	10 1/2	14	8 1/4	9	1 1/8	
SPECIAL	36	5/8	7/8	6C	3	3	11 3/4	12 3/4	17	10	11	2 1/4	

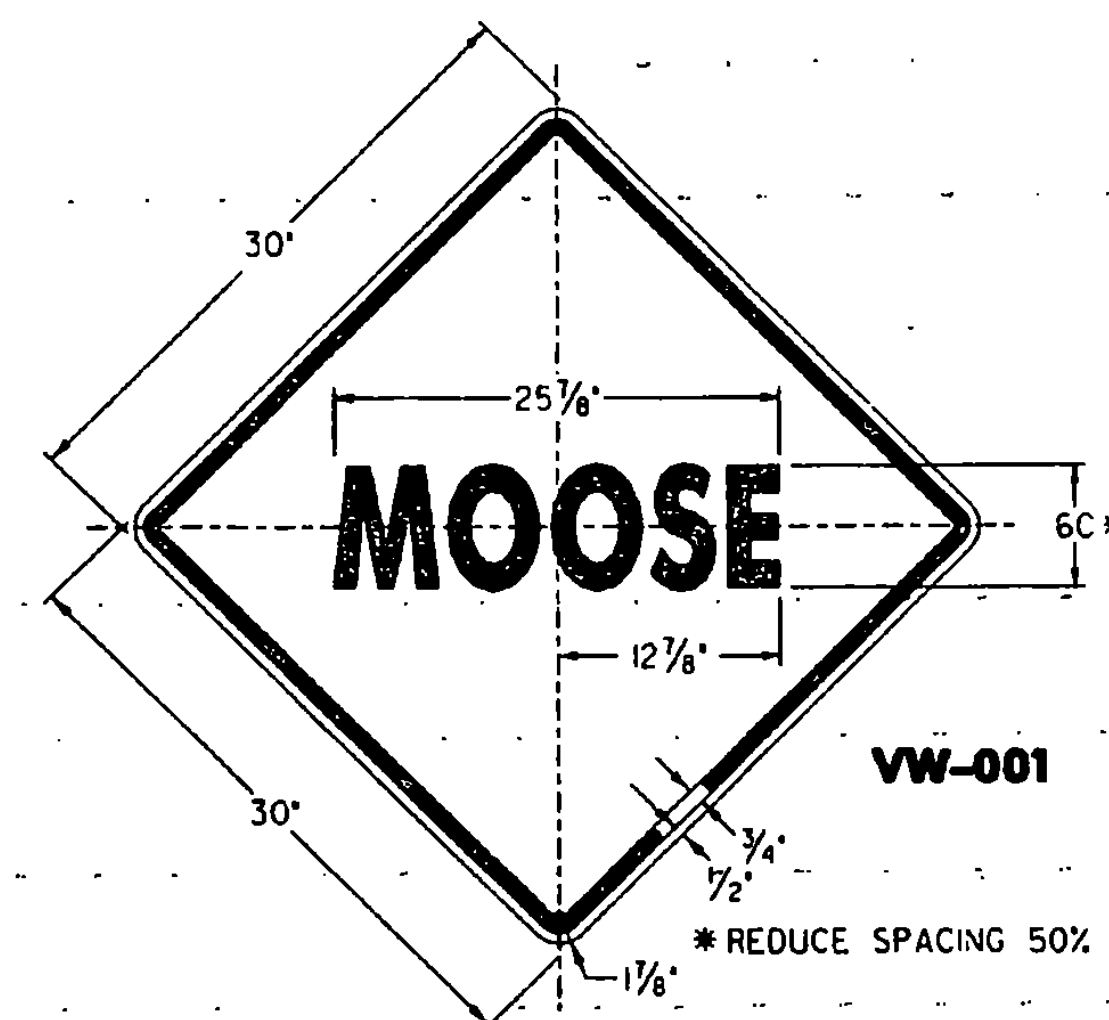

VW-001

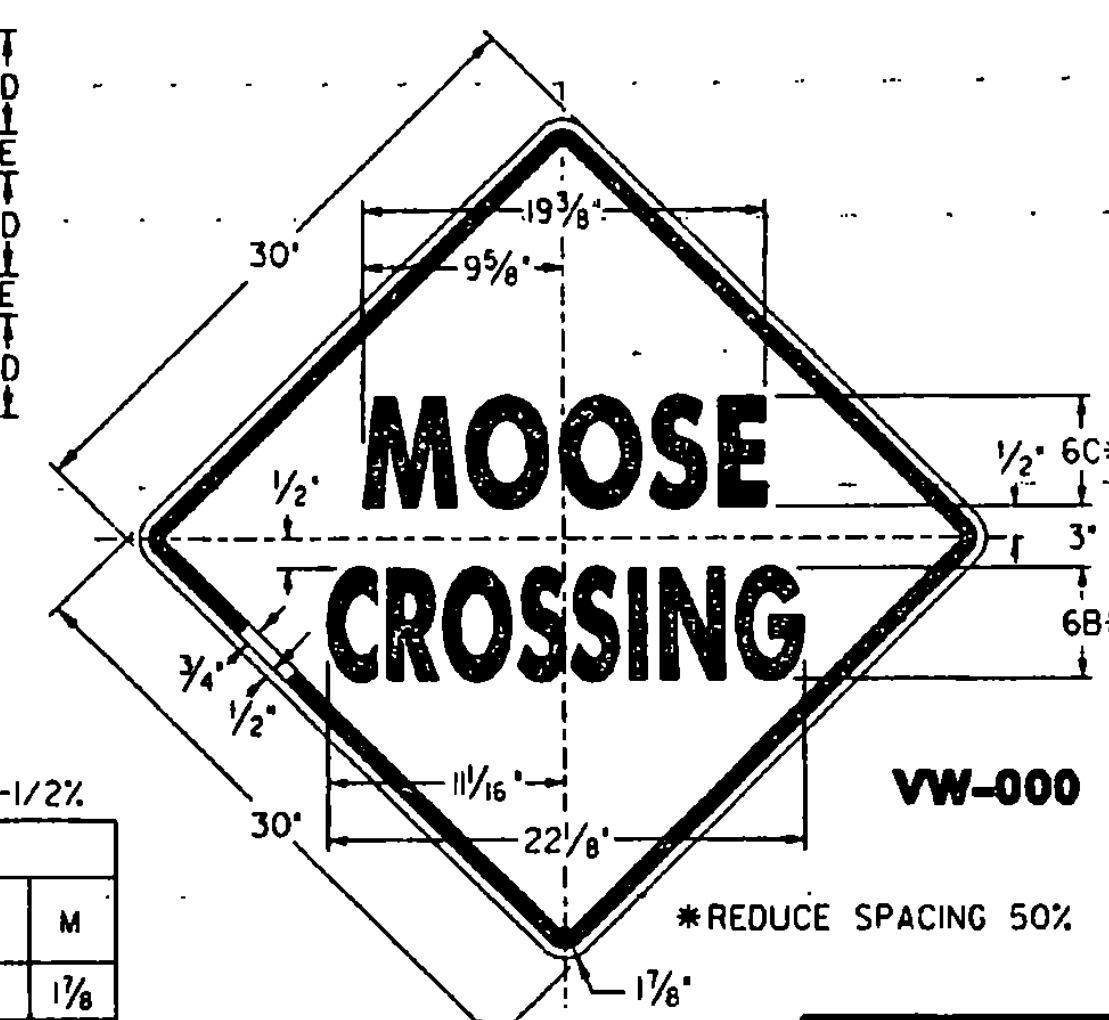

VW-000

COLORS

ALL THE WARNING SIGNS SHOWN ON THIS SHEET SHALL HAVE BLACK TEXT AND SYMBOLS ON REFLECTORIZED YELLOW BACKGROUND EXCEPT AS OTHERWISE NOTED. THE COLORS SHALL CONFORM WITH THE COLORS ADOPTED BY THE AMERICAN ASSOCIATION OF STATE HIGHWAY AND TRANSPORTATION OFFICIALS AND APPROVED BY THE DEPARTMENT OF TRANSPORTATION, FEDERAL HIGHWAY ADMINISTRATION.

MATERIALS

THE SIGN BASE MATERIALS USED FOR THE WARNING SIGNS SHOWN ON THIS SHEET MAY BE ANY OF THE FOLLOWING, OF THE MINIMUM THICKNESS NOTED.

24" x 8"			
24" x 10"			
24" x 18"	36" x 12"		
24" x 24"	36" x 15"	48" x 16"	
30" x 30"	36" x 36"	48" x 20"	

FLAT SHEET ALUMINUM	0.080"	0.100"	0.125"
HIGH DENSITY OVERLAIN PLYWOOD	1/2"	5/8"	5/8"
GALVANIZED FLAT SHEET STEEL	16 GAGE	14 GAGE	12 GAGE

THE TEXT, BORDER AND SYMBOL SHALL BE LETTERING FILM, SILK SCREENED OR HAND PAINTED. WHEN HAND PAINTED, POOR WORKMANSHIP SHALL BE CAUSE FOR REJECTION. THE REFLECTIVE MATERIAL SHALL BE REFLECTIVE SHEETING APPLIED TO THE ENTIRE BACKGROUND OF THE SIGN. ENCAPSULATED LENS REFLECTIVE SHEETING SHALL BE USED FOR THE SIGN BACKGROUND WHERE NOTED. THE HINGE MATERIALS USED FOR THE WARNING SIGNS SHOWN ON THIS SHEET ARE A STANDARD ALUMINUM 2" PIANO HINGE WITH BLACK ENAMEL PAINT, USE AN ALUMINUM 3/16" POP RIVET WITH STEEL SHANK.

TEXT DESIGN

LETTERS, DIGITS, SYMBOLS, SPACINGS, AND TEXT DIMENSIONS SHALL CONFORM WITH THE STANDARD ALPHABETS AND DESIGNS PRESCRIBED IN THE MANUAL ON UNIFORM TRAFFIC CONTROL DEVICES.

SPECIFICATIONS

WARNING SIGNS SHALL MEET THE VERMONT STANDARD SPECIFICATIONS FOR 'TRAFFIC SIGNS'.

OTHER STDS. REQUIRED:

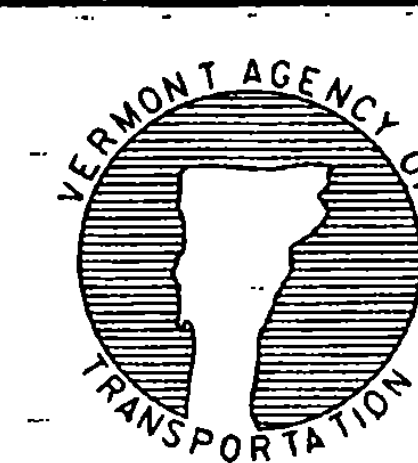

STANDARD
E-153

REVISIONS AND CORRECTIONS
AUG. 08, 1995 - DATE OF ORIGINAL ISSUE
JAN. 15, 1997 - ADDED HINGE DETAIL

APPROVED
[Signature]
DIRECTOR OF ENGINEERING
[Signature]
DIRECTOR OF CONSTRUCTION & MAINTENANCE

WARNING SIGN
DETAILS