



TEMPORARY AND DURABLE 100 mm YELLOW LINE

STA 1+400	TO	1+652	SOL ID	LT & RT
STA 1+664	TO	2+184	SOL ID	LT & RT
STA 2+198	TO	2+384	SOL ID	LT & RT
STA 2+398	TO	2+600	SOL ID	LT & RT

TEMPORARY AND DURABLE 100 mm WHITE LINE

STA 1+400	TO	1+646	SOL ID	RT
STA 1+400	TO	2+178	SOL ID	LT
STA 1+670	TO	2+600	SOL ID	RT
STA 2+202	TO	2+378	SOL ID	LT
STA 2+402	TO	2+600	SOL ID	LT

REMOVING SIGNS
AS SHOWN - 9

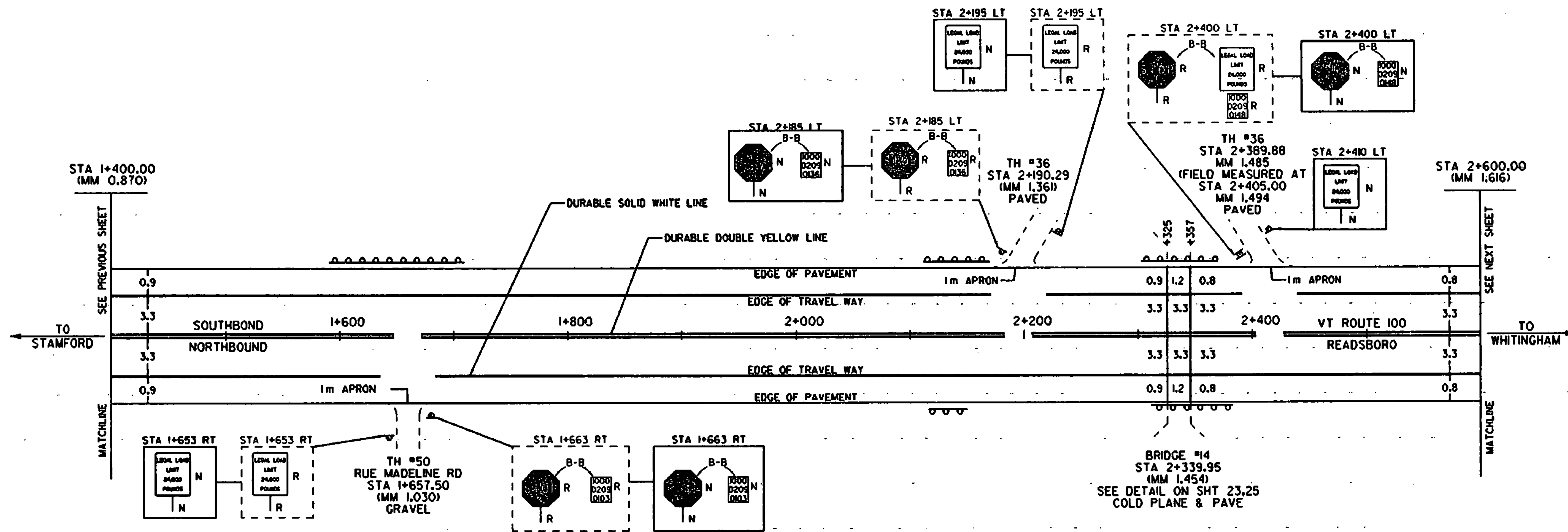

STEEL BEAM GUARDRAIL

STA 1+606	TO	1+705	LT
STA 2+133	TO	2+163	LT
STA 2+136	TO	2+147	RT

REMOVAL & DISP. OF GUARDRAIL

STA 1+605	TO	1+697	LT
STA 2+134	TO	2+174	LT

MODIFIED ECCENTRIC LOADER TERMINAL

STA 1+606	LT
STA 1+705	LT
STA 2+133	LT
STA 2+163	LT
STA 2+136	RT
STA 2+147	RT

LEGEND

- R = REMOVE EXISTING
- N = NEW
- RET = RETAIN
- B-B = BACK TO BACK
- R&S = REMOVE & SALVAGE
- S = SALVAGE
- - = NEW RAIL
- - - = EXISTING RAIL

PAVING PROJECT LAYOUT	PROJECT: STAMFORD-READSBORO	PROJECT NO.: STP 97L1(1)S
	DESIGN FILE NAME: D:\pave\96c020\pc020.dwg	PLOT DATE: 24-MAR-1997
	PARM FILE NAME: pc020.prl	SURVEY DATE: 11-95
	SURVEYED BY: GJB, Jnc	DRAWN BY: SMC
	SQUAD LEADER: JAW	SHEET: 5 OF 28

DATUM

VERTICAL	_____
HORIZONTAL	_____

NOT TO SCALE

: Sheet Number: