

CHAMPLAIN WATER DISTRICT
 403 Queen City Park Road
 South Burlington, VT 05403
 Phone: (802) 864-7454
 Fax: (802) 864-0435

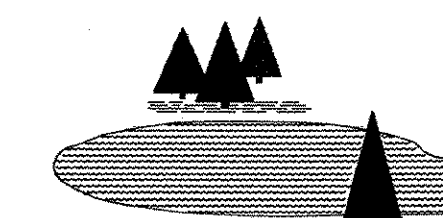

Dedicated to Quality
 Water and Service

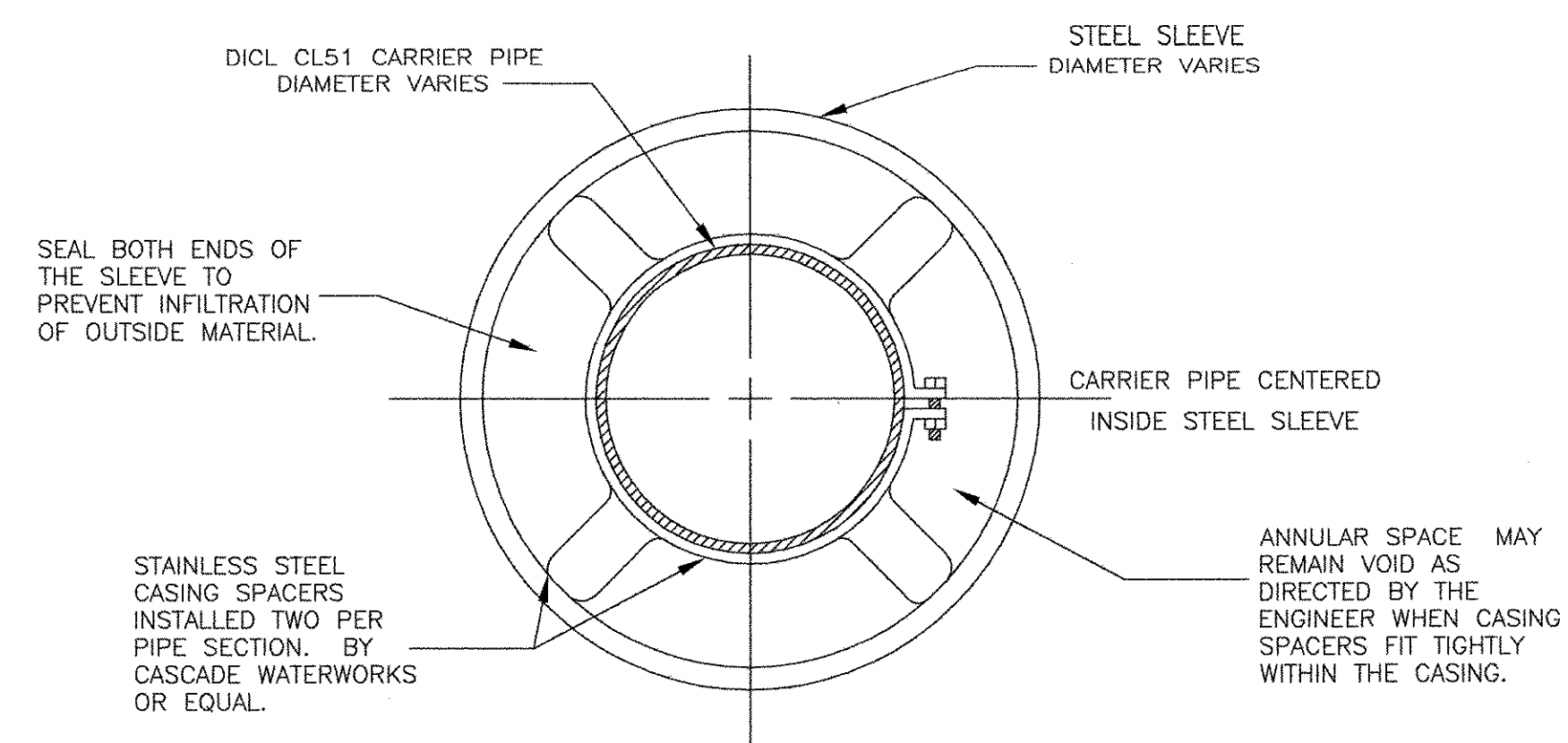

STEEL SLEEVE CASING SPACER DETAIL

NOT TO SCALE

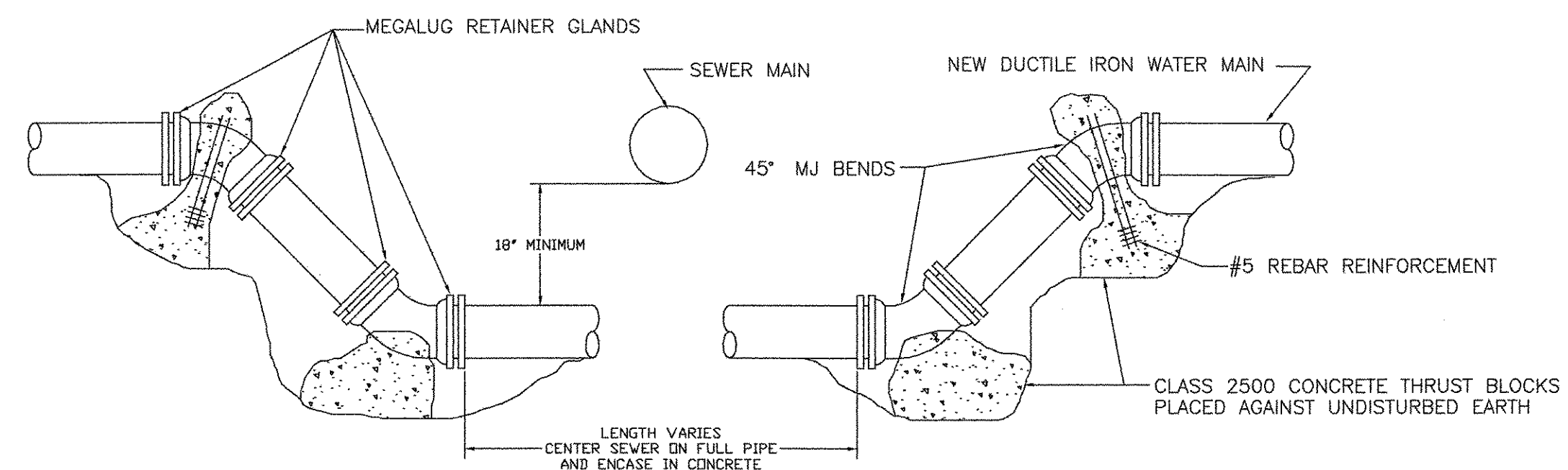

WATERLINE CROSSING SEWER LINE DETAIL

NOT TO SCALE

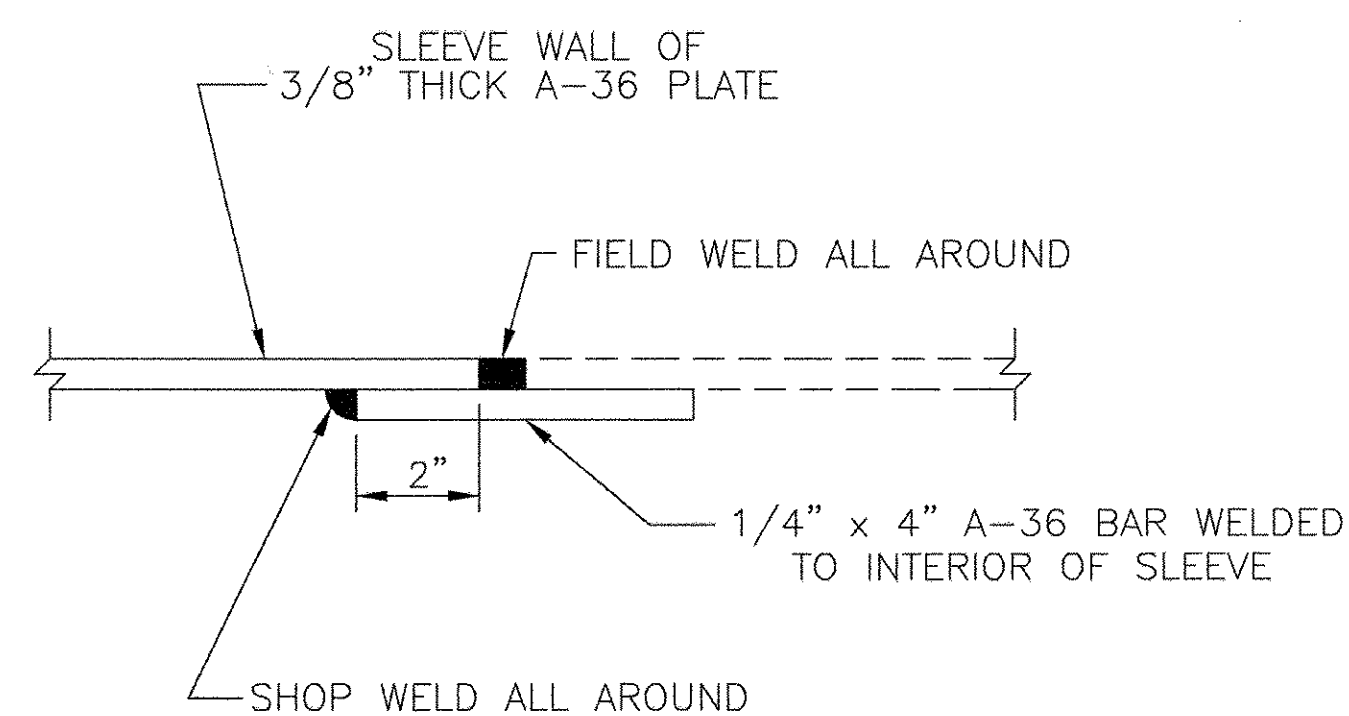

**STEEL SLEEVE ENCASEMENT
 JOINT WELD DETAIL**

NOT TO SCALE

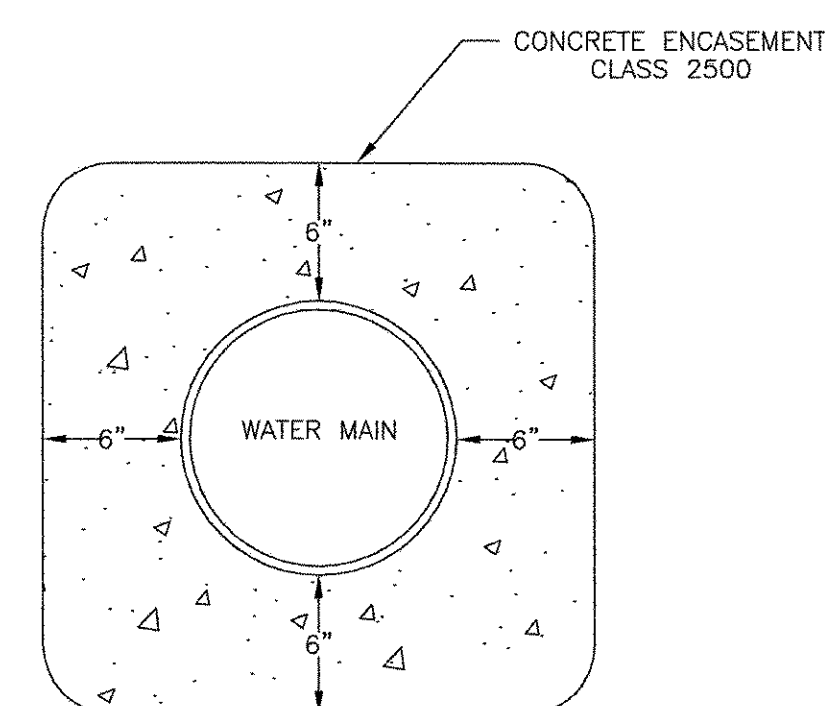

**WATER LINE CONCRETE
 ENCASEMENT DETAIL**

NOT TO SCALE

SCALE: NONE



REVISIONS		
REV. #	DATE	BY

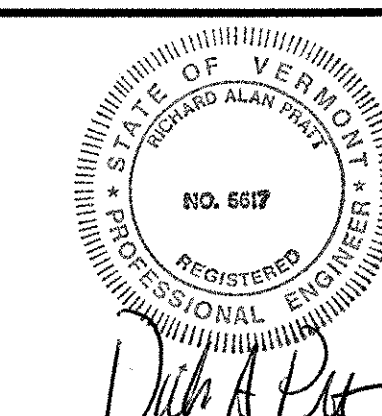

CONTRACT #63
 WATER MAIN
 RELOCATION
 U.S. ROUTE 7 -
 SHELBURNE ROAD

TYPICALS

DATE:	APRIL, 2002
DESIGNED BY:	RAP
DRAWN BY:	EJP
CHECKED BY:	RAP
APPROVED BY:	RAP
FILE NAME:	C63_TYP2
SHEET 18 OF 18	
DRAWING No.	